

FULL INVERTER R32

POMPE A CHALEUR POUR PISCINE

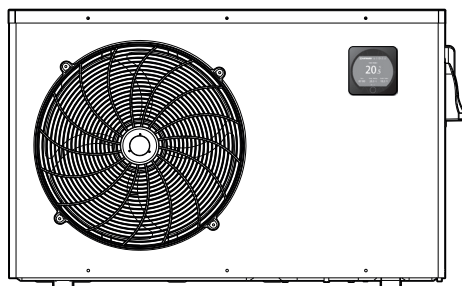

Manuel d'instructions et d'installation

SOMMAIRE

1. PRÉFACE	1
-------------------	----------

2. CARACTÉRISTIQUES TECHNIQUES	4
2.1 Données techniques de la pompe à chaleur	4
2.2 Plage de fonctionnement	5
2.3 Dimensions	6

3. INSTALLATION ET RACCORDEMENT	7
3.1 Schéma de principe	7
3.2 Pompe à chaleur	7
3.3 Raccordement hydraulique	8
3.4 Raccordement électrique	9
3.5 Premier démarrage	10
3.6 Réglage du débit d'eau	12

4. INTERFACE UTILISATEUR	13
4.1 Présentation générale	13
4.2 Réglage Date et Heure	15
4.3 Réglage des Timers Marche/Arrêt	16
4.4 Réglage du point de consigne	18
4.5 Verrouillage et déverrouillage de l'écran tactile	19
4.6 Activation et réglage du mode SILENCE	20

5. ENTRETIEN ET HIVERNAGE	23
5.1 Entretien	23
5.2 Hivernage	23

6. ANNEXES	24
6.1 Schémas électriques	24
6.2 Raccordements priorité chauffage Pompe Monophasé	26
6.3 Vues éclatées et pièces détachées / Addendum	28
6.4 Guide de dépannage	32
6.5 Garantie	35

À lire attentivement et à conserver pour une consultation ultérieure.

Ce document doit être remis au propriétaire de la piscine et doit être conservé par celui-ci en lieu sûr.

1. PRÉFACE

Nous vous remercions d'avoir acheté cette pompe à chaleur de piscine Hayward. La pompe à chaleur Hayward FULL INVERTER a été conçue selon des normes strictes de fabrication pour satisfaire les plus hauts niveaux de qualité requis.

Les pompes à chaleur Hayward vont vous offrir d'exceptionnelles performances tout au long de votre saison de baignade en adaptant la puissance, la consommation électrique et le niveau sonore au besoin de chauffage de votre piscine grâce à la logique de contrôle FULL INVERTER.



Lisez attentivement les consignes de ce manuel avant d'utiliser l'appareil.

Les pompes à chaleur Hayward sont exclusivement destinées à chauffer l'eau de piscine, ne pas utiliser ce matériel à d'autres fins.

Le présent manuel inclut toutes les informations nécessaires concernant l'installation, l'élimination des dysfonctionnements et l'entretien.

Lisez attentivement ce manuel avant d'ouvrir l'unité, ou de réaliser des opérations d'entretien sur celle-ci. Le fabricant de ce produit ne sera en aucun cas tenu responsable en cas de blessure d'un utilisateur ou d'un endommagement de l'unité suite à d'éventuelles erreurs lors de l'installation, de l'élimination des dysfonctionnements, ou d'un entretien inutile. Il est primordial de suivre à tout moment les instructions spécifiées dans ce manuel.

Toute recommandation non suivie annule la garantie.

1. PRÉFACE (suite)



Consignes de sécurité



Cet appareil contient du R32.

Ne jamais utiliser un réfrigérant autre que du R32. Tout autre corps gazeux mélangé avec le R32 risque de provoquer des pressions anormalement élevées pouvant conduire à une panne ou à une rupture de tuyaux et blesser des personnes.

Lors de réparations ou d'opérations de maintenance ne jamais utiliser des tubes de cuivre dont l'épaisseur est inférieure à 0,8 mm.

La pompe à chaleur étant sous pression ne jamais percer les tuyaux ni tenter de faire une brasure. Il y a risque d'explosion.

Ne jamais exposer l'appareil à des flammes, des étincelles ou autre sources d'allumage. Il pourrait exploser et entraîner des blessures graves voire mortelles.

- En cas de stockage la pompe à chaleur doit être stockée dans une pièce bien ventilée et d'une surface au sol de plus de A_{\min} (m²) donnée par la formule suivante : $A_{\min} = (M/(2.5 \times 0.22759 \times h_0))^2$
M est la charge de réfrigérant dans l'appareil en kg et h0 est la hauteur de stockage. Pour un stockage au sol h0 = 0,6 m.
- La pompe à chaleur est exclusivement prévue pour une installation à l'extérieur des bâtiments.
- L'unité doit être installée par un personnel qualifié.
- Ne pas installer la pompe à chaleur sur un support risquant d'amplifier les vibrations de l'unité.
- Vérifier que le support prévu pour l'unité est convenablement dimensionné pour le poids de l'appareil.
- Ne pas installer la pompe à chaleur dans un endroit susceptible d'amplifier son niveau sonore ou dans un endroit où le bruit de l'unité risquerait de gêner le voisinage.
- Tous les raccordements électriques doivent être effectués par un électricien professionnel qualifié et selon les normes en vigueur dans le pays d'installation cf § 3.4.
- Couper l'alimentation principale et le sectionneur avant tous travaux électriques. Tout oubli peut être cause d'électrocution.

1. PRÉFACE (suite)

- Avant l'installation vérifier que le câble de terre n'est pas coupé ou déconnecté. Raccorder et serrer convenablement le câble d'alimentation électrique. Si la connexion est mauvaise, des parties électriques peuvent être endommagées.
- L'exposition de la pompe à chaleur à l'eau ou à un milieu humide risque de provoquer une électrocution. Soyez très vigilant.
- Si vous détectez tout défaut ou situation anormale, n'installez pas la pompe à chaleur et contactez immédiatement votre revendeur.
- L'entretien et les différentes opérations doivent être réalisés à la fréquence et aux moments recommandés, tel que spécifié dans le présent manuel.
- Les réparations doivent être effectuées par un personnel qualifié.
- N'utilisez que des pièces détachées d'origine.
- Ne jamais utiliser un autre procédé de nettoyage que celui préconisé dans ce manuel.

Informations importantes concernant le réfrigérant utilisé

Ce produit contient des gaz à effet de serre fluorés encadrés par le protocole de Kyoto. Ne libérez pas ces gaz dans l'atmosphère.

Type de réfrigérant : R32

Valeur GWP(1) : 675, Valeur basée sur le 4ème rapport du GIEC.

La quantité de réfrigérant basée sur la réglementation F Gaz 517/2014 est indiquée sur la plaque signalétique de l'unité.

Des inspections périodiques de fuite de réfrigérant peuvent être exigées en fonction de la législation européenne ou local. Veuillez contacter votre distributeur local pour plus d'informations.

(1) Potentiel de réchauffement global

2. CARACTÉRISTIQUES TECHNIQUES

2.1 Données techniques de la pompe à chaleur

Modèles	CLASSIC FULL INVERTER	ECL115MA(*)	ECL120MA(*)	ECL130MA(*)	ECL140MA(*)
Tension d'alimentation	V	220V-240V ~ / 1ph / 50Hz			
Réfrigérant	/	R32			
Charge	kg	0,350	0,430	0,480	0,650
Masse en teqCO ₂	/	0,24	0,29	0,32	0,44
Fréquence du contrôle de fuite	/	Aucune exigence mais conseillé de façon annuelle			
Capacité de chauffage Min--Max ^(a)	kW	1,62--7,33	2,18--8,97	1,97 --11,66	2,85--17,06
Puissance électrique absorbée Min--Max ^(a)	kW	0,15--1,17	0,17--1,54	0,16--1,99	0,26--3,13
Courant nominal de service Min--Max ^(a)	A	1,15--5,32	1,27--6,91	1,08--8,96	1,41--13,69
COP Max--Min (a)	/	11,04--6,30	12,77--5,81	12,57--5,84	11,08--5,45
Capacité de chauffage Min--Max ^(b)	kW	1,44--5,36	1,58--6,94	1,79--8,62	2,74--13,08
Puissance électrique absorbée Min--Max ^(b)	kW	0,24--1,14	0,27--1,53	0,290--1,90	0,428--2,97
COP Max--Min ^(b)	/	5,98--4,69	5,82--4,53	6,17--4,52	6,40--4,40
Courant maximum de service (CMS)	A	6,4	8,4	10,9	16,6
Calibre du fusible	aM	8	10	16	20
Disjoncteur courbe D	D	8	10	16	20
Courant de démarrage	A	< CMS			
Raccordement hydraulique	mm	50mm			
Débit d'eau nominal (a)	m ³ /h	3,10	3,80	4,90	7,30
Perte de charge sur l'eau max	kPa	2,3	2,9	6,4	6,7
Compresseur	/	DC Inverter Mitsubishi			DC Inverter Highly
Type	/	Double Rotatif			Double Rotatif
Quantité	/	1			
Résistance d'enroulement à 20°C	Ohm	1,91			0,788
Ventilateur	/	Axial			
Quantité	/	1			
Diamètre	mm	405			510
Nombre de pale	/	3			
Moteur	/	DC Inverter			
Quantité	/	1			
Vitesse de rotation	Tr/min	600--700	600--800	850--950	600--850
Vitesse Mode Silence	Tr/min	400	400	400	300
Niveau de pression acoustique à 1m	dB(A)	35	43	43	46
Niveau de pression acoustique à 10m	dB(A)	18	25	25	29
Dimensions nettes de l'unité (L-I-H)	mm	1040 / 425 / 615			1130 / 460 / 780
Poids	kg	42	45	46	60

(*) Vérifiez les références machines au moyen du tableau de correspondances (voir étiquette en couverture du manuel).



(a) Air sec 27°C - Humidité relative 78% - Température d'entrée d'eau 26°C.

(b) Air sec 15°C - Humidité relative 71% - Température d'entrée d'eau 26°C

2. CARACTÉRISTIQUES TECHNIQUES (suite)

2.2 Plage de fonctionnement

Utiliser la pompe à chaleur dans les plages suivantes de températures et d'humidité pour assurer un fonctionnement sûr et efficace.

	Mode chauffage 	Mode Refroidissement 
Température extérieure	-7°C – +35°C	+7°C – +43°C
Température d'eau	+12°C – +32°C	+8°C – +40°C
Humidité relative	< 80%	< 80%
Plage de réglage point de consigne	+15°C – +32°C	+8°C – +32°C



Si la température ou l'humidité ne correspond pas à ces conditions, des dispositifs de sécurité peuvent se déclencher et la pompe à chaleur peut ne plus fonctionner.



La température maximum de chauffage est limitée à +32° Celsius afin d'éviter la détérioration des liners. Hayward décline toutes responsabilités dans le cas d'une utilisation au delà des +32°C.

2. CARACTERISTIQUES TECHNIQUES (suite)

2.3 Dimensions

Modèles :

ECLI15MA / ECLI20MA / ECLI30MA*

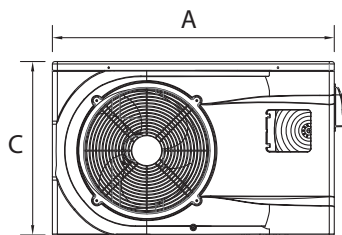
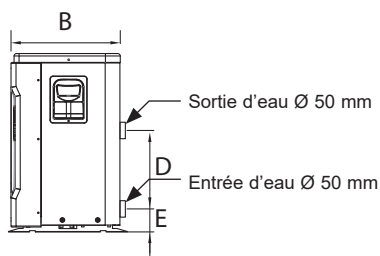

ECLI40MA*

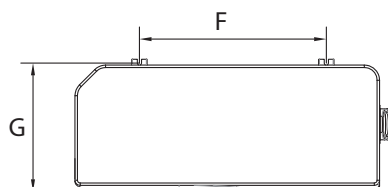
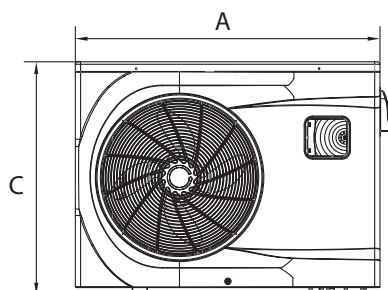
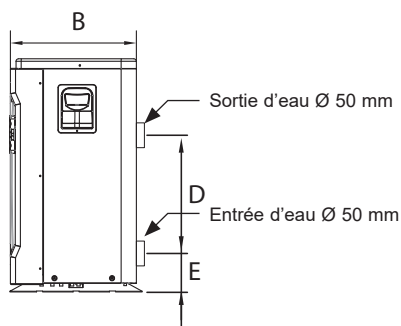

Unité : mm

Repère \ Modèle(*)	ECLI15MA / ECLI20MA / ECLI30MA	ECLI40MA
A	956	1002
B	360	415
C	605	767
D	350	350
E	98	101
F	545	615
G	380	442

(*) Vérifiez les références machines au moyen du tableau de correspondances (voir étiquette en couverture du manuel)

3. INSTALLATION ET RACCORDEMENT

3.1 Schéma de principe

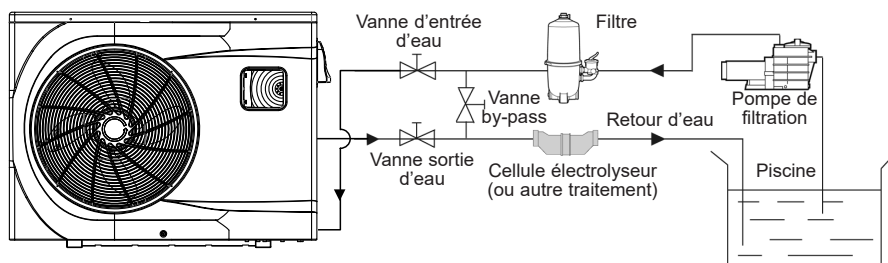

Note : La pompe à chaleur est fournie sans aucun équipement de traitement ou de filtration. Les éléments présentés sur le schéma sont des pièces à fournir par l'installateur.

3.2 Pompe à chaleur



Placer la pompe à chaleur à l'extérieur et en dehors de tout local technique fermé.

Placée sous abri, les distances minimum prescrites ci-dessous doivent être respectées afin d'éviter tout risque de recirculation d'air et une dégradation des performances globales de la pompe à chaleur.

Unité : mm

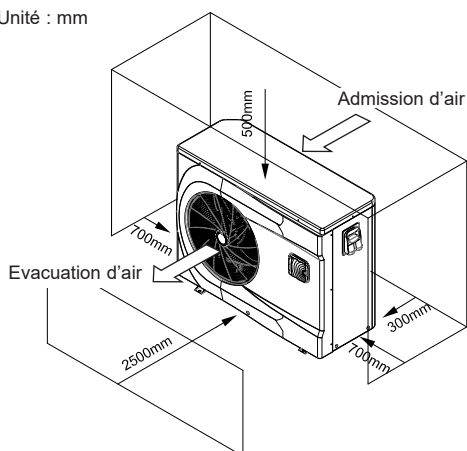

3. INSTALLATION ET RACCORDEMENT (suite)



Installer de préférence la pompe à chaleur sur une dalle béton désolidarisée ou une chaise de fixation prévue à cet effet et monter la pompe à chaleur sur les silentblochs fournis (visserie et rondelles non fournies).

Distance maximale d'installation entre la pompe à chaleur et la piscine 15 mètres.

Longueur totale aller-retour des canalisations hydrauliques 30 mètres. Isoler les canalisations hydrauliques de surface et enterrées.

La pompe à chaleur doit être installée à une distance minimum du bassin conformément à la NF C 15-100 (soit à 3,5 m du plan d'eau pour la France) ou conformément aux normes d'installation en vigueur dans les autres pays.

Ne pas installer la pompe à chaleur à proximité d'une source de chaleur.

En cas d'installation dans des régions neigeuses il est conseillé d'abriter la machine afin d'éviter une accumulation de neige sur l'évaporateur.

3.3 Raccordement hydraulique

La pompe à chaleur est fournie avec deux raccords union Ø 50 mm. Utiliser du tube PVC pour canalisation hydraulique Ø 50 mm. Raccorder l'entrée d'eau de la pompe à chaleur à la conduite venant du groupe de filtration puis raccorder la sortie d'eau de la pompe à chaleur à la conduite d'eau allant au bassin (cf schéma ci-dessous).

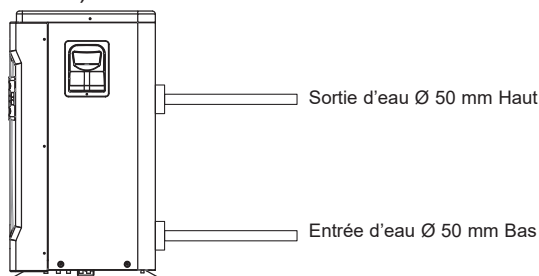

Installer une vanne dite "by-pass" entre l'entrée et la sortie de la pompe à chaleur.



Si un distributeur automatique ou un électrolyseur est utilisé, il doit impérativement être installé après la pompe à chaleur dans le but de protéger le condenseur Titane contre une concentration trop importante de produit chimique.



Veillez à bien installer la vanne by-pass et les raccords union fournis au niveau de l'entrée et de la sortie d'eau de l'unité, afin de simplifier la purge durant la période hivernale, d'en faciliter l'accès ou son démontage pour l'entretien.

3. INSTALLATION ET RACCORDEMENT (suite)

3.4 Raccordement électrique



L'installation électrique et le câblage de cet équipement doivent être conformes aux règles d'installation locales en vigueur.

F	NF C15-100	GB	BS7671:1992
D	DIN VDE 0100-702	EW	EVHS-HD 384-7-702
A	ÖVE 8001-4-702	H	MSZ 2364-702/1994/MSZ 10-553 1/1990
E	UNE 20460-7-702 1993, RECBT ITC-BT-31 2002	M	MSA HD 384-7-702.S2
IRL	Wiring Rules + IS HD 384-7-702	PL	PN-IEC 60364-7-702:1999
I	CEI 64-8/7	CZ	CSN 33 2000 7-702
LUX	384-7.702 S2	SK	STN 33 2000-7-702
NL	NEN 1010-7-702	SLO	SIST HD 384-7-702.S2
P	RSIUEE	TR	TS IEC 60364-7-702



Vérifiez que l'alimentation électrique disponible et la fréquence du réseau correspondent au courant de fonctionnement requis, en prenant en considération l'emplacement spécifique de l'appareil, et le courant nécessaire pour alimenter tout autre appareil connecté au même circuit.

ECLI15MA / ECLI20MA / ECLI30MA / ECLI40MA(*)
230V ~ +/- 10 % 50 Hz 1 Phase

Observez le schéma de câblage correspondant en annexe.
Le boîtier de raccordement se trouve du côté droit de l'unité. Trois connexions sont destinées à l'alimentation électrique, et deux à la commande de la pompe de filtration (Asservissement).

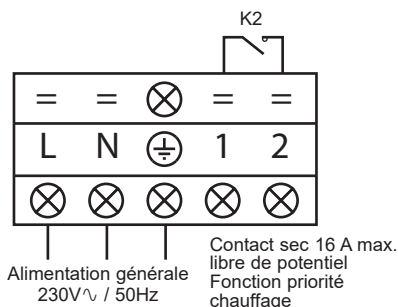

(*) Vérifiez les références machines au moyen du tableau de correspondances (voir étiquette en couverture du manuel)

3. INSTALLATION ET RACCORDEMENT (suite)



La ligne d'alimentation électrique doit être dotée, de manière appropriée, d'un dispositif de protection fusible de type alimentation moteur (aM) ou disjoncteur courbe D ainsi que d'un disjoncteur différentiel 30mA (voir tableau après).

Modèles		ECLI15MA(*)	ECLI20MA(*)	ECLI30MA(*)	ECLI40MA(*)
Alimentation électrique	V/Ph/Hz	230V~ 50Hz	230V~ 50Hz	230V~ 50Hz	230V~ 50Hz
Calibre fusible type aM	A	8 aM	10 aM	16 aM	20 aM
Disjoncteur courbe D	A	8 D	10 D	16 D	20 D
Section de câble	mm ²	3G 2,5	3G 2,5	3G 2,5	3G 4

(*) Vérifiez les références machines au moyen du tableau de correspondances (voir étiquette en couverture du manuel)



Utiliser un câble d'alimentation Type RO2V/R2V ou équivalent.



Les sections de câble sont données pour une longueur maximum de 25 m, elles doivent néanmoins être vérifiées et adaptées en fonction des conditions d'installation.



Prenez toujours garde d'arrêter l'alimentation principale avant d'ouvrir la boîte de commande électrique.

3.5 Premier démarrage

Procédure de démarrage - une fois l'installation terminée, suivez et respectez les étapes suivantes :

- 1) Faites pivoter les ventilateurs à la main afin de vérifier qu'il peut tourner librement, et que l'hélice est fixée correctement sur l'arbre du moteur.
- 2) Assurez-vous que l'unité est connectée correctement à l'alimentation principale (voir le schéma de câblage en annexe).
- 3) Activez la pompe de filtration.
- 4) Vérifiez que toutes les vannes d'eau sont ouvertes, et que l'eau s'écoule vers l'unité avant de passer en mode chauffage ou refroidissement.
- 5) Vérifiez que le tuyau de purge des condensats est fixé correctement, et ne présente aucune obstruction.
- 6) Activez l'alimentation électrique destinée à l'unité, puis appuyez sur le bouton Marche/Arrêt  sur le panneau de commande.
- 7) Assurez-vous que les symboles d'alarme ou de verrouillage ne s'affichent pas. Le cas échéant voir le guide de dépannage (voir § 6.4).

3. INSTALLATION ET RACCORDEMENT (suite)

- 8) Fixez le débit d'eau à l'aide de la vanne by-pass (voir § 3.6 et 2.1), tel que prévu respectivement pour chaque modèle, de manière à obtenir une différence de température Entrée/Sortie de 2°C.
- 9) Après un fonctionnement de quelques minutes, vérifiez que l'air sortant de l'unité s'est refroidi (entre 5 et 10°).
- 10) L'unité étant en service, désactivez la pompe de filtration. L'unité doit s'arrêter automatiquement et afficher le code d'erreur E03 (voir § 6.4).
- 11) Faites fonctionner l'unité et la pompe de la piscine 24 heures sur 24, jusqu'à ce que la température de l'eau souhaitée soit atteinte. Quand la température d'entrée d'eau atteint la valeur de consigne, l'unité s'arrête. Elle redémarre alors automatiquement (tant que la pompe de la piscine est en service) si la température de la piscine est inférieure d'au moins 0.5°C à la température de consigne.

Contrôleur de débit - L'unité est dotée d'un contrôleur de débit qui active la pompe à chaleur lorsque la pompe de filtration de la piscine est en service, et la désactive lorsque la pompe de la filtration est hors service. Par manque d'eau, le code d'alarme E03 s'affiche sur le régulateur (Voir § 6.4).

Temporisation - l'unité intègre une temporisation de 3 minutes, afin de protéger les composants du circuit de commande, d'éliminer toute instabilité en terme de redémarrage et, toute interférence au niveau du contacteur. Grâce à cette temporisation, l'unité redémarre automatiquement 3 minutes environ après toute coupure du circuit de commande. Même une coupure de courant de courte durée active la temporisation de démarrage.

3. INSTALLATION ET RACCORDEMENT (suite)

3.6 Réglage du débit d'eau

Les vannes d'entrée et de sortie d'eau étant ouvertes, ajuster la vanne dite "by-pass" de façon à obtenir une différence de 2°C entre la température d'entrée et de sortie d'eau (voir schéma de principe § 3.1).

Vous pouvez vérifier le réglage en visualisant les températures entrée/sortie directement sur le panneau de commande.



Note : L'ouverture de la vanne dite "by-pass" engendre un débit moins important d'ou une augmentation du ΔT .

La fermeture de la vanne dite "by-pass" engendre un débit plus important d'ou une diminution du ΔT .

4. INTERFACE UTILISATEUR

4.1 Présentation générale

La pompe à chaleur est équipée d'un panneau de commande digital à écran tactile, raccordé électriquement et pré-réglé en usine en mode chauffage.

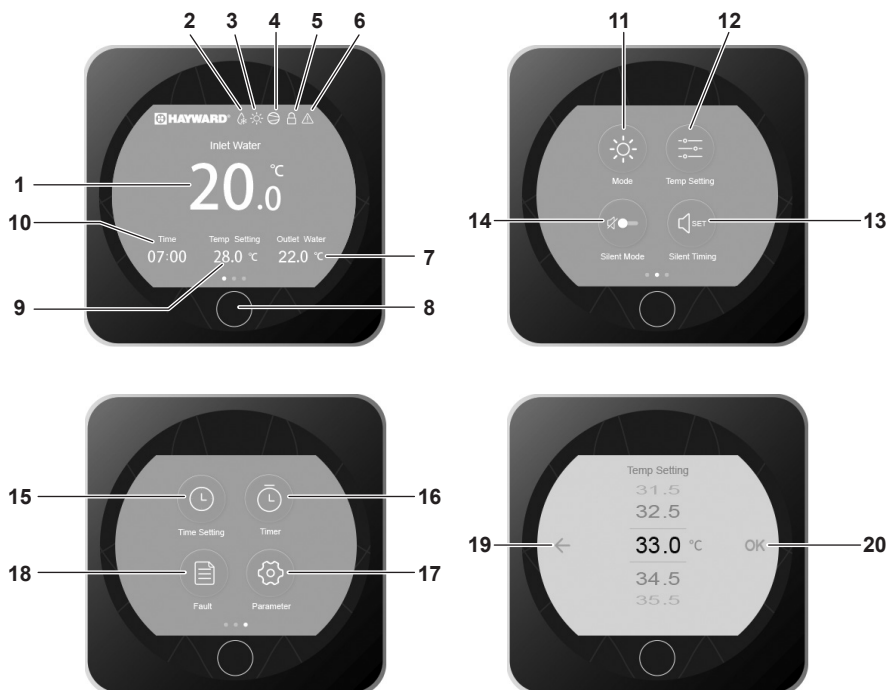

Légende

1	Température d'entrée d'eau
2	Dégivrage en cours
3	Mode de fonctionnement
4	Témoin de marche du compresseur
5	Verrouillage de l'écran
6	Alarme
7	Température de sortie d'eau
8	Marche/Arrêt/Retour
9	Température de consigne
10	Heure

11	Sélection du mode de fonctionnement
12	Réglage du point de consigne
13	Réglage Timer mode silence
14	Activation du mode silence
15	Réglage date et heure
16	Réglage Timers Marche/Arrêt
17	Accès paramètres avancés
18	Retour (sans validation)
19	Retour (sans validation)
20	Validation

4. INTERFACE UTILISATEUR (suite)

Mode OFF/ARRET

Lorsque la pompe à chaleur est à l'arrêt (en veille), l'inscription OFF apparaît sur l'écran.

L'écran noir indique que la pompe à chaleur est à l'arrêt. Le réglage des paramètres est possible dans ce mode.



Mode ON/MARCHE

Lorsque la pompe à chaleur est en fonctionnement ou en régulation (atteinte du point de consigne) l'écran devient bleu.



Pour passer du mode OFF au mode ON et inversement appuyer sur le bouton .

4. INTERFACE UTILISATEUR (suite)

4.2 Réglage Date et Heure

Le réglage de la date et de l'heure peut se faire indifféremment en mode ON ou OFF.

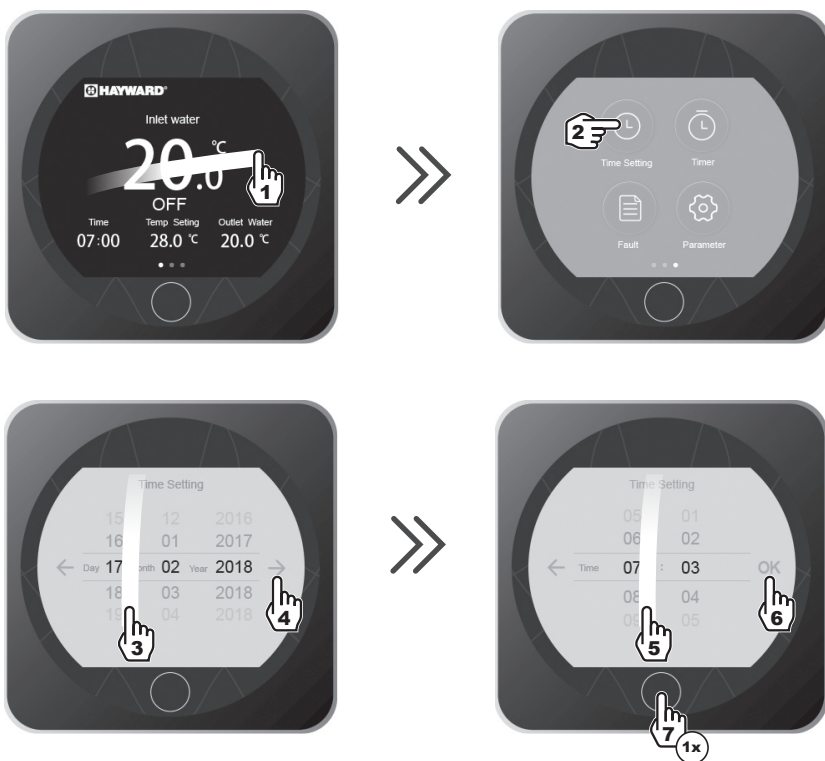

- Presser 1 fois sur  pour revenir à l'écran principal.

4. INTERFACE UTILISATEUR (suite)

4.3 Réglage des Timers Marche/Arrêt

Le réglage de cette fonction est nécessaire dès lors que vous souhaitez faire fonctionner votre pompe à chaleur sur une plus courte période que celle définie par l'horloge de filtration. Ainsi vous pourrez programmer un départ différé et un arrêt anticipé ou simplement interdire une plage horaire de fonctionnement (par exemple la nuit).

Vous avez la possibilité de programmer un Timer Départ et un Timer Arrêt. Le pas de réglage est "d'heure en heure".



4. INTERFACE UTILISATEUR (suite)



Surbrillance bleue = Activé
Grisé = Désactivé

- Presser 2 fois sur  pour revenir à l'écran principal.

4. INTERFACE UTILISATEUR (suite)

4.4 Réglage du point de consigne

Le réglage du point de consigne s'effectue indifféremment en mode ON ou en mode OFF avec une précision de 0,5°C.



- Presser 1 fois sur  pour revenir à l'écran principal.



Il est recommandé de ne jamais dépasser la température de 30°C pour éviter l'altération des liners.

4. INTERFACE UTILISATEUR (suite)

4.5 Verrouillage et déverrouillage de l'écran tactile

Le verrouillage et déverrouillage de l'écran peut se faire indifféremment en mode ON ou en mode OFF.



Verrouillage activé



Verrouillage désactivé

4. INTERFACE UTILISATEUR (suite)

4.6 Activation et réglage du mode SILENCE

Le mode silence permet une utilisation de la pompe à chaleur en mode économique et très silencieux lorsque les besoins de chauffage sont faibles (maintien en température du bassin, ou besoin d'avoir un fonctionnement ultra silencieux).

Cette fonction peut être Activée/Désactivée manuellement, ou à l'aide d'un Timer.

Activation / Désactivation



Mode silence désactivé



Mode silence activé



- Presser 1 fois sur  pour revenir à l'écran principal.

4. INTERFACE UTILISATEUR (suite)

Réglage du Timer du mode silence



4. INTERFACE UTILISATEUR (suite)



- Presser 2 fois sur  pour revenir à l'écran principal.



**Le pas de réglage est "d'heure en heure".
Une fois le Timer activé, celui-ci est actif 7 jours sur 7.**

5. ENTRETIEN ET HIVERNAGE

5.1 Entretien

Ces opérations de maintenance doivent être réalisées 1 fois par an afin de garantir la longévité et le bon fonctionnement de la pompe à chaleur.

- Nettoyer l'évaporateur à l'aide d'une brosse souple ou d'un jet d'air ou d'eau (**Attention ne jamais utiliser un nettoyeur haute pression**).
- Vérifier le bon écoulement des condensats.
- Vérifier le serrage des raccords hydrauliques et électriques.
- Vérifier l'étanchéité hydraulique du condenseur.
- Faire vérifier l'étanchéité du circuit frigorifique au détecteur de fuite **par un professionnel agréé**.



Avant toute opération de maintenance la pompe à chaleur doit être déconnectée de toute source de courant électrique. Les opérations de maintenance doivent être réalisées uniquement par un personnel qualifié et habilité à manipuler les fluides frigorigènes.

5.2 Hivernage

- Mettre la pompe à chaleur en Mode "OFF".
- Couper l'alimentation de la pompe à chaleur.
- Vider le condenseur à l'aide de la vidange pour éviter tout risque de dégradation (risque important de gel).
- Fermer la vanne "by-pass" et dévisser les raccords unions entrée/sortie.
- Chasser au maximum l'eau stagnante résiduelle du condenseur à l'aide d'un pistolet à air.
- Obturer l'entrée et la sortie d'eau sur la pompe à chaleur pour éviter l'intrusion de corps étranger.
- Couvrir la pompe à chaleur avec la housse d'hivernage prévue à cet effet.



Tout dommage occasionné par un mauvais hivernage entraîne l'annulation de la garantie.

6. ANNEXES

6.1 Schémas électriques

ECLI15MA / ECLI20MA / ECLI30MA (*)

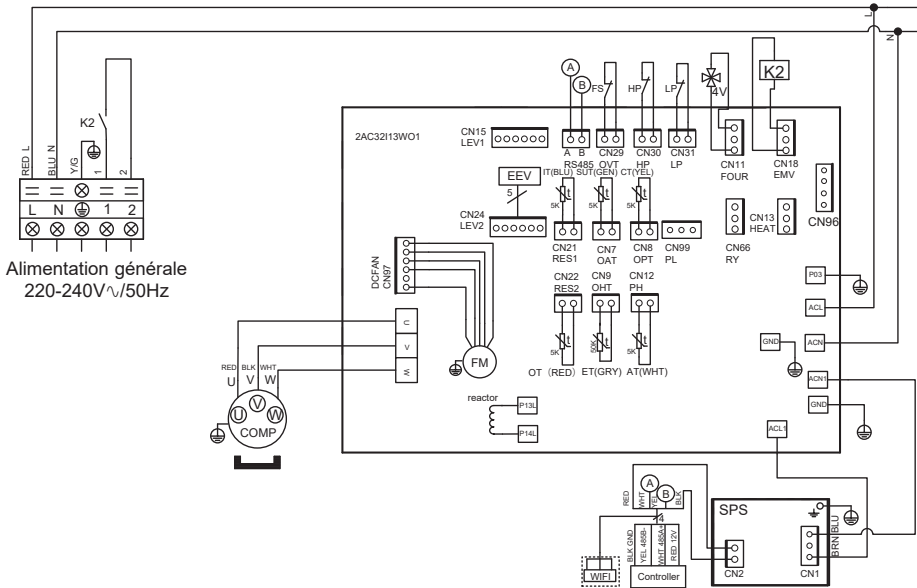

LEGENDE

- | | |
|---|--|
| AT : SONDE DE TEMPÉRATURE D'AIR | LP : PRESSOSTAT BASSE PRESSION |
| COMP : COMPRESSEUR | OT : SONDE DE TEMPÉRATURE SORTIE D'EAU |
| CT : SONDE TEMPÉRATURE ÉVAPORATEUR | SUT : SONDE DE TEMPÉRATURE D'ASPIRATION |
| EEV : DÉTENDEUR ÉLECTRONIQUE | 4V : VANNE 4 VOIES |
| FM : MOTEUR VENTILATEUR | K2 : CONTACT SEC MAX. 16A |
| FS : DÉTECTEUR PRÉSENCE D'EAU | ET : SONDE TEMPÉRATURE REFOULEMENT |
| HP : PRESSOSTAT HAUTE PRESSION | ----- : OPTION |
| IT : SONDE DE TEMPÉRATURE ENTRÉE D'EAU | |

(*) Vérifiez les références machines au moyen du tableau de correspondances (voir étiquette en couverture du manuel)

6. ANNEXES (suite)

6.2 Raccordements priorité chauffage Pompe Monophasé

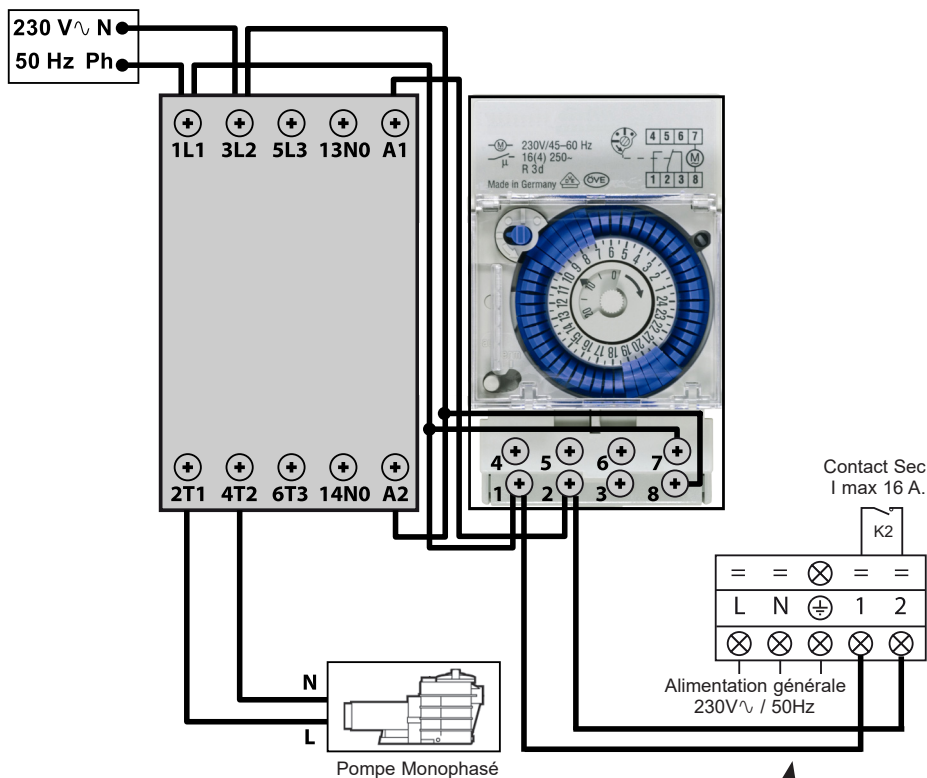

Les bornes 1-2 délivrent un contact sec libre de potentiel, sans polarité 230 V \sim / 50 Hz.
Câbler les bornes 1 et 2 en respectant le câblage indiqué ci-dessus afin d'asservir le fonctionnement de la pompe de filtration par cycle de 2 min. toutes les heures si la température du bassin est inférieure au point de consigne.

 Ne jamais raccorder l'alimentation de la pompe de filtration directement sur les bornes 1 et 2.



Page laissée blanche intentionnellement

6. ANNEXES (suite)

6.3 Vues éclatées et pièces détachées / Addendum

ECLI15MA / 20MA / 30MA / 40MA (*)

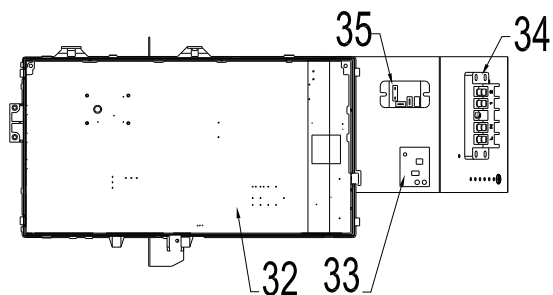
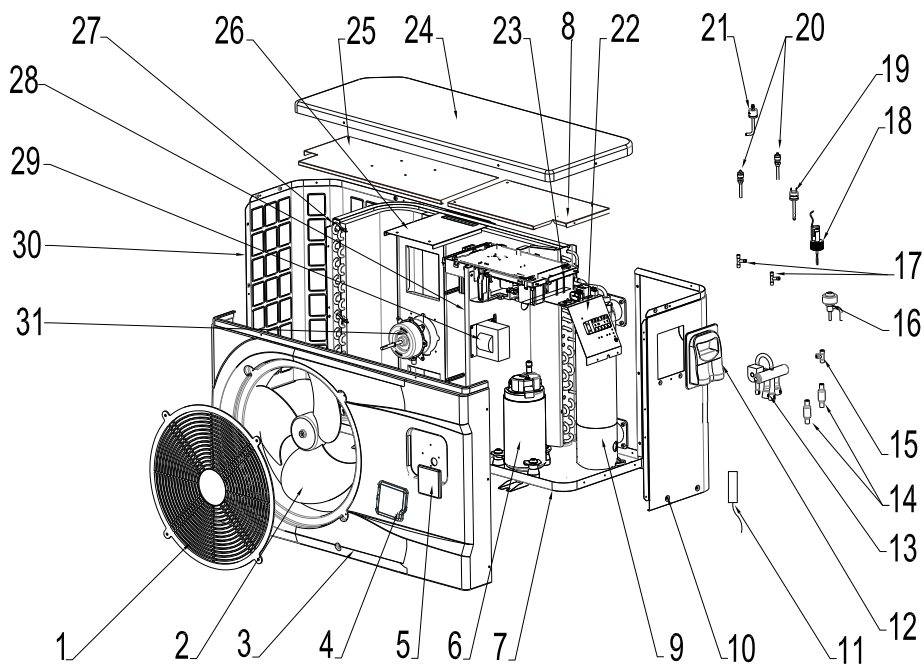

6. ANNEXES (suite)

Rep	Désignation	Réf.	ECLI15MA*	ECLI20MA*	ECLI30MA*	ECLI40MA*
1	Grille de protection ventilateur	HWX20000220245	✓	✓	✓	n/a
		HWX20000220369	n/a	n/a	n/a	✓
2	Hélice Ventilateur	HWX301030000006	✓	✓	✓	n/a
		HWX301030000001	n/a	n/a	n/a	✓
3	Panneau Avant	HWX809000099	✓	✓	✓	n/a
		HWX809001100	n/a	n/a	n/a	✓
4	Porte de protection	HWX809000320	✓	✓	✓	✓
5	Régulateur LED	HWX82300038	✓	✓	✓	✓
6	Compresseur	HWX20000110448	✓	✓	✓	n/a
		HWX80100003	n/a	n/a	n/a	✓
7	/	/	/	/	/	/
8	/	/	/	/	/	/
9	Condenseur Titane PVC	HWX80600037	✓	n/a	n/a	n/a
		HWX32012120061	n/a	✓	n/a	n/a
		HWX32012120056	n/a	n/a	✓	n/a
		HWX806000096	n/a	n/a	n/a	✓
10	Panneau Droit	HWX80700445	✓	✓	✓	n/a
		HWX80700314	n/a	n/a	n/a	✓
11	Sonde Aspiration Compresseur 5k-560mm	HWX83000044	✓	✓	✓	n/a
	Sonde Aspiration Compresseur 5k-760mm	HWX83000053	n/a	n/a	n/a	✓
	Sonde température Air 5k-350mm	HWX83000049	✓	✓	✓	✓
	Sonde Sortie d'eau 5k-410mm	HWX83000050	✓	✓	✓	✓
	Sonde Entrée d'eau 5k-850mm	HWX83000052	✓	✓	✓	✓
	Sonde Refoulement Compresseur 50k-660mm	HWX83000026	✓	✓	✓	✓
	Sonde de dégivrage 5k-680mm	HWX83000051	✓	✓	✓	n/a
Sonde de dégivrage 5k-1040mm	HWX83000045	n/a	n/a	n/a	✓	
12	Trappe d'accès électrique	HWX320922029	✓	✓	✓	✓
13	Vanne 4 voies	HWX20041437	✓	✓	✓	✓
14	Filtre ø9.7-ø9.7 (Ø19)	HWX20000140178	✓	✓	✓	n/a
	Filtre ø9.7-ø9.7 (Ø28)	HWX20041444	n/a	n/a	n/a	✓
15	Connecteur T ø9.52-2 x ø6.35(T) x 1.0	HWX30403000002	✓	✓	✓	✓
16	Détendeur électronique	HWX20000140570	✓	✓	✓	n/a
		HWX81000013	n/a	n/a	n/a	✓
17	Connecteur T ø6.5-2 x ø6.5(T) x 0.75	HWX20001460	✓	✓	✓	✓
18	Détecteur de débit d'eau	HWX83000012	✓	✓	✓	✓
19	Pressostat basse pression NO 0.30MPa/0.15MPa	HWX20000360157	✓	✓	✓	✓
20	Prise de pression 40mm-1/2"	HWX20000140150	✓	✓	✓	✓
21	Pressostat haute pression NC 3.2MPa/4.4MPa	HWX20013605	✓	✓	✓	✓
22	/	/	/	/	/	/
23	/	/	/	/	/	/
24	Panneau supérieur	HWX809000055	✓	✓	✓	n/a
		HWX301090200806	n/a	n/a	n/a	✓
25	/	/	/	/	/	/
26	Support Moteur	HWX80700218	✓	✓	✓	n/a
		HWX80700248	n/a	n/a	n/a	✓

(*) Vérifiez les références machines au moyen du tableau de correspondances (voir étiquette en couverture du manuel)

6. ANNEXES (suite)

ECLI15MA / 20MA / 30MA / 40MA (*)

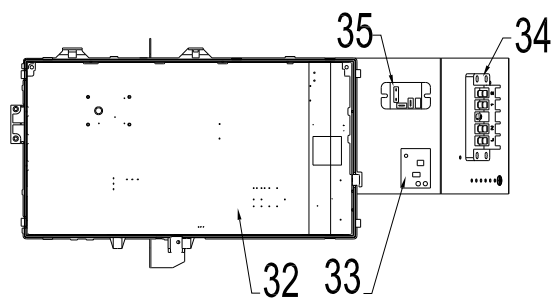
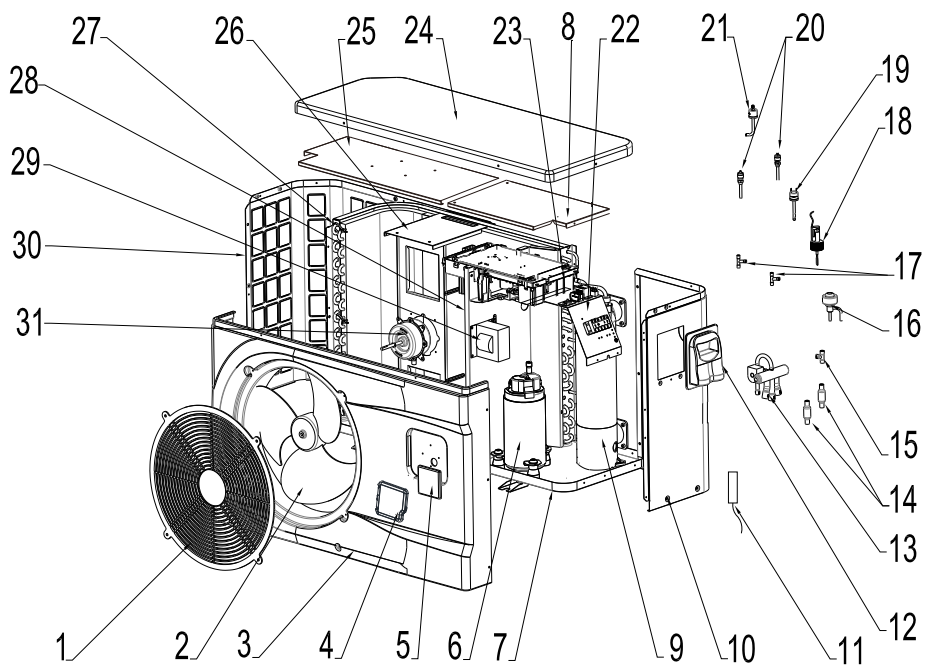

6. ANNEXES (suite)

Rep	Désignation	Réf.	ECL15MA*	ECL20MA*	ECL30MA*	ECL40MA*
27	Evaporateur à ailette	HWX301060202502	✓	n/a	n/a	n/a
		HWX80600042	n/a	✓	n/a	n/a
		HWX80600043	n/a	n/a	✓	n/a
		HWX80600044	n/a	n/a	n/a	✓
28	/	/	/	/	/	
29	Bobine 16A 50Hz 5mH	HWX82500006	✓	✓	✓	n/a
	Bobine 20A 50Hz 5.2mH	HWX82500005	n/a	n/a	n/a	✓
30	Panneau Gauche	HWX80700446	✓	✓	✓	n/a
		HWX80700315	n/a	n/a	n/a	✓
31	Moteur ventilateur DC	HWX80200018	✓	✓	✓	n/a
		HWX20000330132	n/a	n/a	n/a	✓
32	Carte électronique Driver	HWX82300052	✓	✓	✓	n/a
		HWX82300007	n/a	n/a	n/a	✓
33	Transformateur 230V~/12DC	HWX82600008	✓	✓	✓	✓
34	Bornier L-N-GND -5 connexions 4mm²	HWX40003901	✓	✓	✓	✓
35	Relais K2	HWX20000360297	✓	✓	✓	✓

(*) Vérifiez les références machines au moyen du tableau de correspondances (voir étiquette en couverture du manuel)

6. ANNEXES (suite)

6.4 Guide de dépannage





Certaines opérations doivent être réalisées par un technicien habilité.

En cas de défaut sur la pompe à chaleur, le symbole  apparaît dans l'angle supérieur gauche de l'écran.

Pour plus de détail, consulter le tableau ci-après.



Après résolution du problème l'erreur est acquitée automatiquement, le triangle disparaît.

- Pour effacer la liste d'erreur, appuyer sur  .
- Presser 2 fois sur  pour revenir à l'écran principal.

6. ANNEXES (suite)

Dysfonctionnement	Codes d'erreur	Description	Solution
Défaut sonde entrée d'eau	P01	Le capteur est ouvert ou en court circuit	Vérifier la connectique CN21/RES1 sur la carte et le connecteur rallonge ou remplacer le capteur
Défaut sonde de sortie d'eau	P02		Vérifier la connectique N22/RES2 sur la carte et le connecteur rallonge ou remplacer le capteur
Défaut sonde température extérieure	P04		Vérifier la connectique CN12/PH sur la carte et le connecteur rallonge ou remplacer le capteur
Défaut sonde dégivrage	P05		Vérifier la connectique CN8/OPT sur la carte et le connecteur rallonge ou remplacer le capteur
Défaut sonde d'aspiration Compresseur	P07		Vérifier la connectique CN7/OAT sur la carte et le connecteur rallonge ou remplacer le capteur
Défaut sonde de refoulement Compresseur	P081		Vérifier la connectique CN9/OHT sur la carte et le connecteur rallonge ou remplacer le capteur
Défaut Haute pression	E01	Le capteur est ouvert ou en court circuit	<p>Vérifier la connectique CN30/HP sur la carte ou remplacer le capteur</p> <p>Vérifier le débit d'eau</p> <p>Vérifier le détecteur de débit d'eau</p> <p>Vérifier l'ouverture des vannes</p> <p>Vérifier le by-pass</p> <p>Vérifier l'encrassement de l'évaporateur</p> <p>Température d'eau trop chaude</p> <p>Problème d'incondensable après une maintenance, vider et tirer au vide le circuit frigorifique</p> <p>Charge de fluide trop importante, retirer du fluide dans une bouteille de liquide</p>
Défaut basse pression	E02	Le capteur est ouvert ou en court circuit	<p>Vérifier la connectique CN31/LP sur la carte ou remplacer le capteur</p> <p>Fuite importante de fluide frigorigène, faire une recherche de fuite au détecteur</p> <p>Débit d'air trop faible, vérifier la vitesse de rotation du ventilateur</p> <p>Vérifier l'encrassement de l'évaporateur, nettoyer sa surface</p>
Défaut détecteur de débit	E03	Le capteur est ouvert ou en court circuit	<p>Vérifier la connectique CN29/OVT sur la carte ou remplacer le capteur</p> <p>Manque d'eau, vérifier le fonctionnement de la pompe de filtration</p> <p>Vérifier l'ouverture des vannes d'arrêts</p> <p>Vérifier le réglage du by-pass</p>

6. ANNEXES (suite)

Dysfonctionnement	Codes d'erreur	Description	Solution
Différence de température Entrée/Sortie > 13°C	E06	Applicable en mode Froid seulement	Manque d'eau, vérifier le fonctionnement de la pompe de filtration
			Vérifier l'ouverture des vannes d'arrêts
			Vérifier le réglage du by-pass
Protection Anti-gel	E07	Température de sortie d'eau < à 4°C	Stopper la pompe à chaleur, vidanger le condenseur risque de gel
Problème de communication	E08	Pas de communication entre la carte électronique et l'interface utilisateur	Vérifier les raccordements et la connectique - voir schéma électrique
Protection Anti-gel de niveau 1	E19	2°< Température d'eau <4° et Température d'air <0°	Arrêter le fonctionnement de la pompe à chaleur, vidanger le condenseur pour éviter le gel, par défaut la pompe à chaleur démarre la pompe de filtration pour éviter la prise en glace
Protection Anti-gel de niveau 2	E29	Températures d'eau < à 2° et Température d'air < 0°	Arrêter le fonctionnement de la pompe à chaleur, vidanger le condenseur pour éviter le gel, par défaut la pompe à chaleur démarre la pompe de filtration et la pompe à chaleur pour éviter la prise en glace.
Défaut moteur ventilateur	F031	Moteur bloqué ou défaut de connexion	Vérifier la libre rotation; vérifier la connectique CN97/DCFan; remplacer le moteur
Défaut moteur ventilateur	F051	Défaut de connexion	Vérifier la connectique DCFAN/CN97 ; remplacer le moteur
Température extérieure trop basse	TP	Limite de fonctionnement atteinte	Arrêter la pompe à chaleur

6. ANNEXES (suite)

6.5 Garantie

CONDITIONS DE GARANTIE

Tous les produits HAYWARD sont garantis contre tous vices de fabrication ou de matière pendant une période de deux années à compter de la date d'achat. Toute demande de garantie devra être accompagnée d'une preuve d'achat justifiant sa date. Nous vous incitons donc à conserver votre facture.

La garantie HAYWARD est limitée à la réparation ou au remplacement, au choix d'HAYWARD, des produits défectueux pour autant qu'ils aient subi un emploi normal, en accord avec les prescriptions mentionnées dans leur manuel d'utilisation, que le produit n'ait été modifié d'aucune sorte et utilisé uniquement avec des composants et des pièces HAYWARD. Les dommages dus au gel et aux attaques d'agents chimiques ne sont pas garantis.

Tous les autres frais (transport, main d'œuvre...) sont exclus de la garantie.

HAYWARD ne pourra être tenu pour responsable d'aucun dommage direct ou indirect provenant de l'installation, du raccordement ou du fonctionnement incorrect d'un produit.

Pour faire jouer une garantie et demander la réparation ou le remplacement d'un article, adressez vous à votre revendeur. Aucun retour de matériel à notre usine ne sera accepté sans notre accord écrit préalable.

Les pièces d'usure ne sont pas couvertes par la garantie.

Page laissée blanche intentionnellement

FULL INVERTER R32

SWIMMING POOL HEAT PUMP UNIT

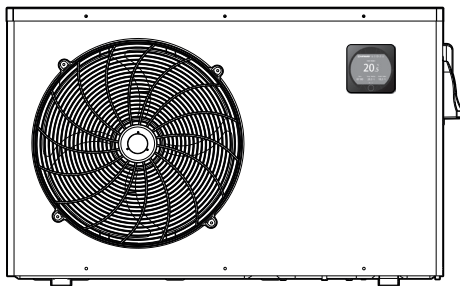

Installation & Instruction Manual

CONTENTS

1. PREFACE	1
2. Technical Specifications	4
2.1 Heat pump technical data	4
2.2 Operating range	5
2.3 Dimensions	6
3. INSTALLATION AND CONNECTION	7
3.1 Functional Diagram	7
3.2 Heat pump unit	7
3.3 Hydraulic connection	8
3.4 Electrical connection	9
3.5 Initial start-up	10
3.6 Water flow setting	12
4. USER INTERFACE	13
4.1 General presentation	13
4.2 Timer function settings	15
4.3 Setting the On/Off timers	16
4.4 Adjust setpoint	18
4.5 Locking and unlocking the touch screen	19
4.6 SILENT function settings	20
5. MAINTENANCE AND WINTERISING	23
5.1 Maintenance	23
5.2 Winterising	23
6. APPENDIX	24
6.1 Electrical diagrams	24
6.2 Heating priority wiring for monophasic pump	26
6.3 Exploded view and spare parts / Addendum	28
6.4 Troubleshooting guide	32
6.5 Warranty	35

Please read attentively and save for future consultation.

This document must be given to the pool owner and should be kept in a safe place.

1. PREFACE

Thank you for purchasing the Hayward heat pump for swimming pools. The Hayward FULL INVERTER heat pump has been designed to strict manufacturing standards meeting the highest levels of quality required.

Hayward heat pumps offer you exceptional performance throughout your bathing season by adapting wattage, power usage and noise levels to the heating requirements of your swimming pool thanks to FULL INVERTER control logic.



Read the instructions in this manual carefully before using the device.

Hayward heat pumps are designed exclusively to heat swimming pool water; do not use this equipment for any other purpose.

This manual includes all the necessary information for installation, trouble-shooting and maintenance.

Read this manual carefully before opening the unit or doing any maintenance work on it. The manufacturer of this product shall on no account accept any liability for injury to a user or damage to the unit further to any errors made during installation, trouble-shooting or unnecessary maintenance. It is particularly important to follow the instructions given in this manual at all times.

Otherwise the guarantee will be voided.

1. PREFACE (continued)



Safety instructions



This device contains R32.

Never use a refrigerant other than R32. Any other gaseous body mixed with R32 could cause abnormally high pressure and lead to a failure or pipes bursting and injuring people.

When carrying out repairs or maintenance work, never use copper tubes less than 0.8 mm thick.

As the heat pump is pressurized, never pierce the pipes or attempt any brazing. There is a risk of explosion.

Never expose the device to flames, sparks or other sources of ignition. It could explode and cause serious or even fatal injuries.

- If kept in storage, the heat pump should be kept in a well-ventilated room with a floor area of more than A_{\min} (m²) as calculated by the following formula:
$$A_{\min} = (M / (2.5 \times 0.22759 \times h_0))^2$$

M is the quantity of refrigerant in the device in kg, and h₀ is the storage height. If stored on the floor, h₀ = 0.6 m.
- The heat pump is designed exclusively for installation outside buildings.
- The unit must be installed by qualified personnel.
- Do not install the heat pump on a support that risks intensifying the unit's vibrations.
- Make sure the support provided for the unit is strong enough to bear the weight of the unit.
- Do not install the heat pump anywhere liable to amplify its noise level or anywhere where its noise could disturb neighbours.
- All the electrical connections must be fitted by a professional qualified electrician in accordance with the standards in force in the country of installation, see §3.4.
- Shut off the main power supply and disconnecting switch before doing any electrical work. Forgetting to do so could cause electrocution.
- Before installing the unit, check that the earth cable is not cut or disconnected.

1. PREFACE (continued)

- Connect and properly tighten the power cable. A loose connection could damage electrical components.
- Exposing the heat pump to water or a humid atmosphere could cause electrocution. Be very careful.
- If you detect a fault or any abnormal situation, do not install the heat pump and contact your dealer immediately.
- All maintenance work should be done at the recommended intervals, as specified in this manual.
- Repairs must be carried out by qualified personnel.
- Only use OEM spare parts.
- Never use a cleaning method other than the one recommended in this manual.

Important information concerning the refrigerant used

This makes contains fluorinated greenhouse gases regulated by the Kyoto protocol. Do not release these gases into the atmosphere.

Type of refrigerant: R32

GWP(1) value: 675, based in the 4th report of the IPCC.

The quantity of refrigerant, based on the F-Gas regulation no. 517/2014, is stated on the unit's rating plate.

Period checks for leaks of refrigerant may be required by European or local legislation. Please contact your local dealer for more information.

(1) Global warming potential

2. TECHNICAL SPECIFICATIONS

2.1 Heat pump technical data

Models	CLASSIC FULL INVERTER	ECLI15MA(*)	ECLI20MA(*)	ECLI30MA(*)	ECLI40MA(*)
Supply voltage	V	220V-240V ~/1ph/50Hz			
Refrigerant	/	R32			
Load	kg	0.350	0.430	0.480	0.650
Mass in teqCO ₂	/	0.24	0.29	0.32	0.44
Leak check frequency	/	No specific frequency, but an annual check is recommended			
Min--Max heating capacity ^(a)	kW	1.62--7.33	2.18--8.97	1.97--11.66	2.85--17.06
Min--Max electric input power ^(a)	kW	0.15--1.17	0.17--1.54	0.16--1.99	0.26--3.13
Min--Max continuous current rating ^(a)	A	1.15--5.32	1.27--6.91	1.08--8.96	1.41--13.69
Max--Min continuous power (COP) (a)	/	11.04--6.30	12.77--5.81	12.57--5.84	11.08--5.45
Min--Max heating capacity ^(b)	kW	1.44--5.36	1.58--6.94	1.79--8.62	2.74--13.08
Min--Max electric input power ^(b)	kW	0.24--1.14	0.27--1.53	0.290--1.90	0.428--2.97
Max--Min continuous power (COP) ^(b)	/	5.98--4.69	5.82--4.53	6.17--4.52	6.40--4.40
Maximum continuous current	A	6.4	8.4	10.9	16.6
Fuse rating	aM	8	10	16	20
Circuit-breaker curve D	D	8	10	16	20
Starting current	A	< maximum continuous current			
Hydraulic connection	mm	50 mm			
Nominal water flow (a)	m ³ /h	3.10	3.80	4.90	7.30
Max. loss of head on water	kPa	2.3	2.9	6.4	6.7
Compressor	/	Mitsubishi DC Inverter			Highly DC Inverter
Type	/	Twin rotary			Twin rotary
Quantity	/	1			
Coil resistance at 20°C	Ohm	1.91			0.788
Fan	/	Axial			
Quantity	/	1			
Diameter	mm	405			510
Number of blades	/	3			
Motor	/	DC Inverter			
Quantity	/	1			
Rotation speed	rpm	600--700	600--800	850--950	600--850
Silent mode speed	rpm	400	400	400	300
Sound pressure level at 1 metre	dB(A)	35	43	43	46
Sound pressure level at 10 metres	dB(A)	18	25	25	29
Unit's net dimensions (L-W-H)	mm	1040/425/615			1130/460/780
Weight	kg	42	45	46	60

(*) Check the machine references on the conversion table (see label on the cover of the manual).



(a) Dry air 27°C - Relative humidity 78% - Water inlet temperature 26°C.

(b) Dry air 15°C - Relative humidity 71% - Water inlet temperature 26°C

2. TECHNICAL SPECIFICATIONS (continued)

2.2 Operating range

Use the swimming pool heat pump unit within the following ranges of temperature and humidity to ensure safe and efficient operation.

	Heating mode 	Cooling mode 
Outside temperature	-7°C – +35°C	+7°C – +43°C
Water temperature	+12°C – +32°C	+8°C – +40°C
Relative humidity	< 80%	< 80%
Setting range from the set point	+15°C – +32°C	+8°C – +32°C



If the temperature or humidity does not correspond to these conditions, the security measures could be activated and the swimming pool heat pump unit may no longer work.



The maximum heating temperature is set at 32°C to prevent damage to the liners. Hayward cannot be held responsible if used at a temperature above +32°C.

2. TECHNICAL SPECIFICATIONS (continued)

2.3 Dimensions

Models:

ECLI15MA / ECLI20MA / ECLI30MA*

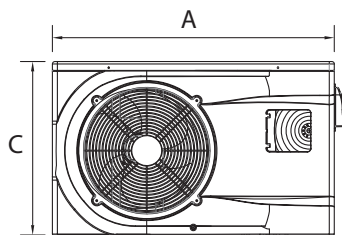
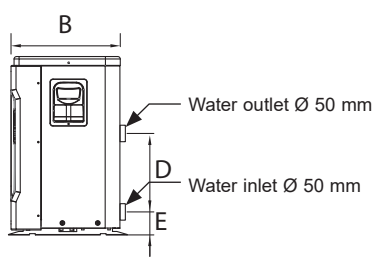

ECLI40MA*

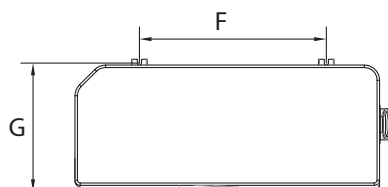
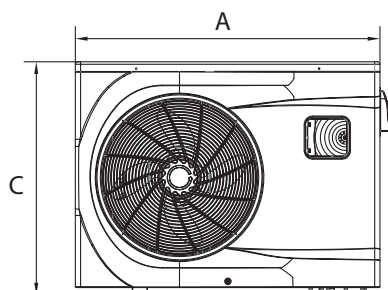
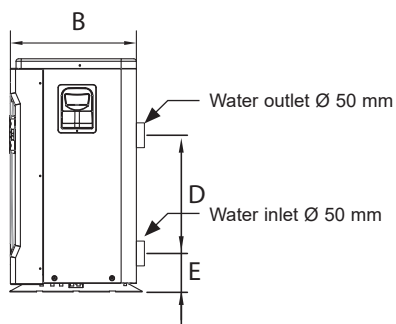

Unit: mm

Size \ Type(*)	ECLI15MA / ECLI20MA / ECLI30MA	ECLI40MA
A	956	1002
B	360	415
C	605	767
D	350	350
E	98	101
F	545	615
G	380	442

(*) Check the machine references on the conversion table (see label on the cover of the manual).

3. INSTALLATION AND CONNECTION

3.1 Functional Diagram

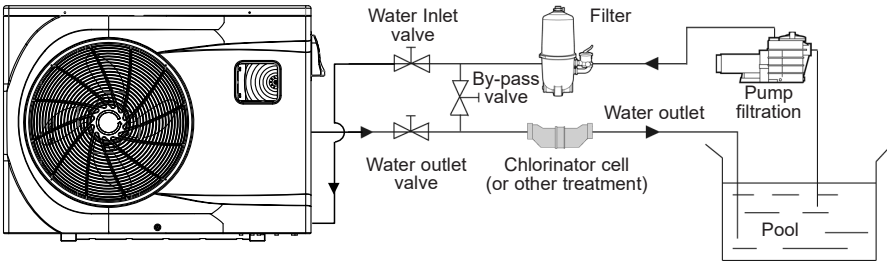

Note : The swimming pool heat pump unit is sold without any treatment or filtration equipment. The components presented in the diagram are spare parts to be supplied by the installer.

3.2 Heat pump unit



Place the heat pump outdoors and away from any enclosed technical space.

Placed under a shelter, the minimum required distances mentioned below must be respected in order to avoid any risk of air recirculation and a deficiency in the unit's overall performance.

Unit: mm

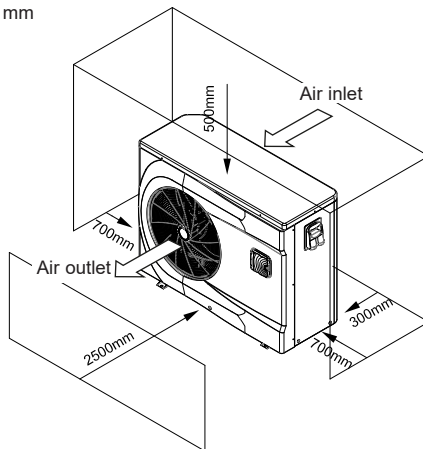

3. INSTALLATION AND CONNECTION (continued)



It is advised to install the unit on a dissociated cement block or a mounting bracket designed for this use and to set up the unit on the supplied rubber bushing (fastenings and washers not supplied).

The maximum installation distance between the unit and the swimming pool is 15 metres.

The total length of the piping to and from the unit is 30 metres.

Insulate both the above ground and buried hydraulic piping.

The heat pump must be installed at a minimum distance from the pool in compliance with NF C 15-100 (3.5 m from the water for France) or in compliance with installation standards applicable in other countries.

Do not install the heat pump close to a heat source.

For installation in snowy regions we recommend sheltering the machine to avoid snow accumulating on the evaporator.

3.3 Hydraulic connection

The unit is supplied with two 50 mm Ø union connections. Connect the water inlet to the heat pump coming from the filtration group then connect the water outlet to the heat pump at the water conduit going to the pool (see diagram below).

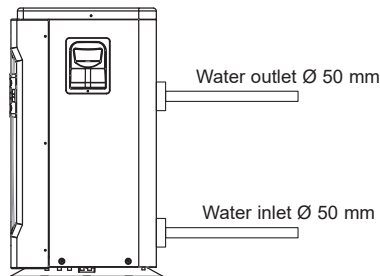

Install a by-pass valve between the heat pump entrance and exit.



If an automatic distributor or an electrolyser is used, it should be installed imperatively after the heat pump with the goal of protecting the titanium condenser against an elevated concentration of chemicals.



Be sure to install the by-pass valve and the supplied union connections at the water inlet and outlet level in order to simplify purging during the winter period and to facilitate access when disassembling for maintenance.

3. INSTALLATION AND CONNECTION (continued)

3.4 Electrical connection



Electrical installation and wiring for this equipment must be in conformity with local installation standards.

F	NF C15-100	GB	BS7671:1992
D	DIN VDE 0100-702	EW	EVHS-HD 384-7-702
A	ÖVE 8001-4-702	H	MSZ 2364-702/1994/MSZ 10-553 1/1990
E	UNE 20460-7-702 1993, RECBT ITC-BT-31 2002	M	MSA HD 384-7-702.S2
IRL	Wiring Rules + IS HD 384-7-702	PL	PN-IEC 60364-7-702:1999
I	CEI 64-8/7	CZ	CSN 33 2000 7-702
LUX	384-7.702 S2	SK	STN 33 2000-7-702
NL	NEN 1010-7-702	SLO	SIST HD 384-7-702.S2
P	RSIUEE	TR	TS IEC 60364-7-702



Verify that the available electrical power supply and the network frequency correspond to the required operating current taking into account the appliance's specific location, and the current required to supply any other appliance connected to the same circuit.

ECLI15MA / ECLI20MA / ECLI30MA / ECLI40MA(*)
230V \sim +/- 10 % 50 Hz 1 Phase

See the corresponding wiring diagram in the appendix.
The connection box is located on the right side of the unit. Three connections are designed for the power supply and two are for controlling the filter pump (Enslavement).

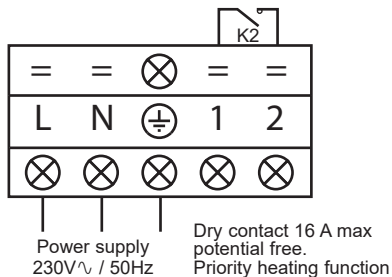

(*) Check the machine references on the conversion table (see label on the cover of the manual).

3. INSTALLATION AND CONNECTION (continued)



The electrical power supply must have, when appropriate, a fuse protection device like a feed motor (aM) or D curve circuit breaker as well as a differential circuit breaker 30mA (see following table).

Models		ECLI15MA(*)	ECLI20MA(*)	ECLI30MA(*)	ECLI40MA(*)
Power supply	V/Ph/Hz	230V~ 50Hz	230V~ 50Hz	230V~ 50Hz	230V~ 50Hz
aM type fuse calibre	A	8 aM	10 aM	16 aM	20 aM
Curve D circuit breaker	A	8 D	10 D	16 D	20 D
Cable section	mm ²	3G 2,5	3G 2,5	3G 2,5	3G 4

(*) Check the machine references on the conversion table (see label on the cover of the manual).



Use an RO 2V/R 2V or equivalent power cord.



The cables sections are given for a maximum length of 25 m. They must however be checked and adjusted according to the installation conditions.



Always shut down the main power supply before opening the electrical control box.

3.5 Initial start-up

Start-up procedure - After installation is complete, follow these steps:

- 1) Rotate the fans by hand to verify that they can turn freely by hand, and that the turbine is correctly affixed to the motor shaft.
- 2) Ensure that the unit is connected correctly to the main power supply (see the wiring diagram in the appendix).
- 3) Activate the filtration pump.
- 4) Verify that all water valves are open and that the water flows toward the unit before switching on the heating or cooling mode.
- 5) Verify that the drainage hose is correctly affixed and that it causes no obstructions.
- 6) Activate the unit power supply, then press the On/Off button  on the control panel.
- 7) Make sure the alarm or lock symbols are not displayed. If need be, see the trouble-shooting guide (see § 6.4).

3. INSTALLATION AND CONNECTION (continued)

- 8) Set the water flow using the by-pass valve (see § 3.6 and 2.1), as provided for by each model, to obtain an Entry/Exit temperature of 2°C.
- 9) After running for several minutes, verify that the air exiting the unit is cool (between 5 and 10°).
- 10) With the unit operating, turn off the filter pump. The unit should automatically turn off and display error code E03 (See § 6.4).
- 11) Allow the unit and the pool pump to run 24 hours per day until the desired water temperature has been reached. When the set water inlet temperature is reached, the unit will turn off. It will automatically restart (as long as the pool pump is running) if the pool temperature is at least 0.5°C below the set temperature.

Water flow switch - The unit is equipped with a flow switch that turns on the heat pump when the pool filtration pump is running, and deactivates it when the filtration pump is out of order. If the water is low, the E03 alarm code will appear on the regulator (See § 6.4).

Time delay - The unit is equipped with a time delay of 3 minutes in order to protect the control circuit components, to eliminate restart cycling and contactor chatter. Thanks to this time delay, the unit automatically restarts approximately 3 minutes after each control circuit interruption. Even a brief power interruption will activate the restart time delay.

3. INSTALLATION AND CONNECTION (continued)

3.6 Water flow setting

With the water entry and exit valves being open, adjust the by-pass valve in order to obtain a difference of 2°C between the inflow and outflow temperature (see principle diagram § 3.1). You can verify the switch by seeing the entry/exit temperatures directly on the control panel.



Note: Opening the by-pass valve creates a weaker flow, which leads to an increase in ΔT .

Closing the by-pass valve creates a stronger flow, which leads to a decrease in ΔT .

4. USER INTERFACE

4.1 General presentation

The heat pump is equipped with a digital control panel with a touch screen, electronically connected and pre-set at the factory in heating mode.

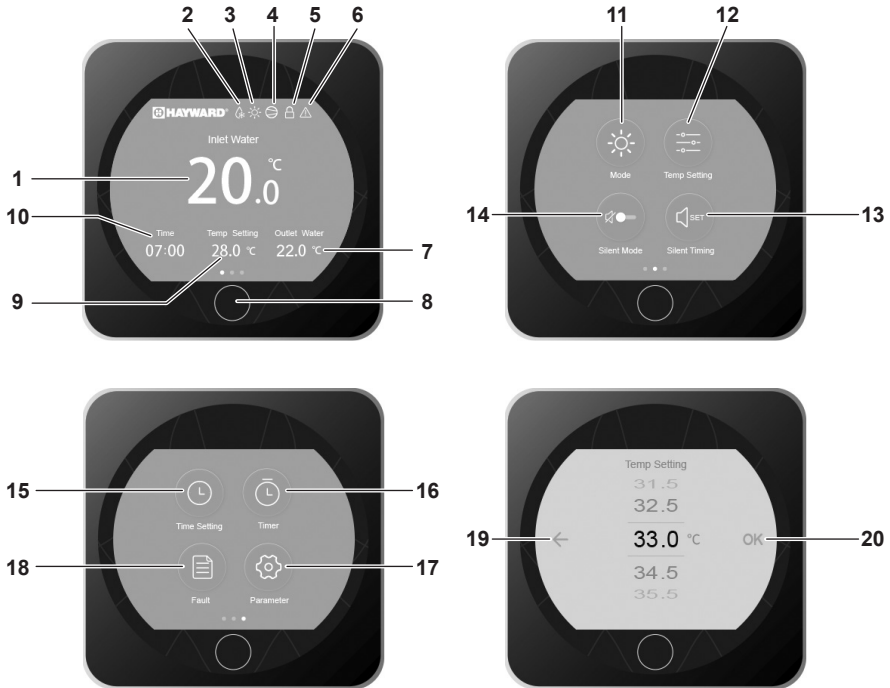

Legend

1	Water Input temperature
2	Defrost mode
3	Operating mode
4	Compressor's ON indicator
5	Lock screen
6	Alarm
7	Water Output temperature
8	On/Off/Back
9	Setpoint temperature
10	Hour

11	Operating mode selection
12	Adjust setpoint
13	Setting silence mode timer
14	Activate silent mode
15	Set date and time
16	Set On/Off timers
17	Access Advanced Settings
18	Access list of faults
19	Back (changes not confirmed)
20	Confirm

4. USER INTERFACE (continued)

OFF mode

When the heat pump is idle (in standby mode), OFF is displayed as shown on the screen.

The black screen indicates that the heat pump is idle; settings can be adjusted in this mode.



ON mode

When the heat pump is running or priming (setpoint reached), the screen turns blue.



To switch from OFF to ON mode and vice versa, press the  button.

4. USER INTERFACE (continued)

4.2 Timer function settings

The date and time can be set either in ON or in OFF mode.



- Press 1 times on  to return to the main screen.

4. USER INTERFACE (continued)

4.3 Setting the On/Off timers

Setting this function is necessary if you would like to run the heat pump for a shorter period than what is defined by the filtration clock. Therefore, you can program a deferred start and an anticipated stop or simply stop a certain timeframe from running (at night, for example).

It is possible to set one Start Timer and one Stop Timer.

The setting step is "hour to hour".



4. USER INTERFACE (continued)



Blue highlighting = Activated
Grey = Deactivated

- Press 2 times on  to return to the main screen.

4. USER INTERFACE (continued)

4.4 Adjust setpoint

The setpoint can be changed either in ON or in OFF mode with an accuracy of 0.5°C.



- Press 1 times on  to return to the main screen.



It is recommended to never exceed 30°C to avoid alteration of the liners.

4. USER INTERFACE (continued)

4.5 Locking and unlocking the touch screen

The screen can be locked or unlocked either in ON or in OFF mode.



Lock activated



Lock deactivated

4. USER INTERFACE (continued)

4.6 SILENT function settings

Silence mode enables the heat pump to be used in economic and very silent mode when the heating needs are low (maintaining the pool temperature or need for ultra-silent operation).

This function can be Activated/Deactivated manually or using a Timer.

Activation/Deactivation

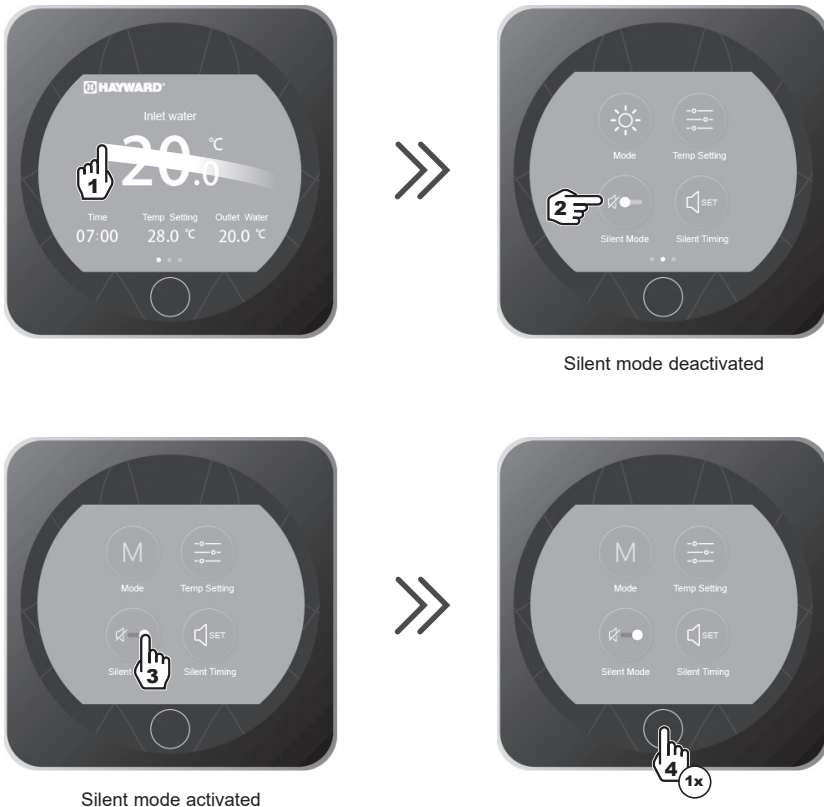

- Press 1 times on  to return to the main screen.

4. USER INTERFACE (continued)

Adjusting the SILENT mode Timer



4. INTERFACE UTILISATEUR (suite)



- Press 2 times on  to return to the main screen.



***The setting step is "hour to hour".
Once the Timer is activated, it is active 7 days a week.***

5. MAINTENANCE AND WINTERISING

5.1 Maintenance

These maintenance operations must be carried out once per year in order to guarantee the longevity and the good working condition of the heat pump.

- Clean the coil with the help of a soft brush or jet of air or water (**Warning, never use a high pressure cleaner**).
- Verify that the drains flow well.
- Verify the tightening of the hydraulic and electrical connections
- Verify the hydraulic sealing of the condenser.
- Have the leak-tightness of the cooling circuit to the leak detector checked by an **accredited professional**.



Before any maintenance operation, the heating pump must be disconnected from any electrical current source. The maintenance operations must only be carried out by personnel that is qualified and authorised to handle liquid refrigerants.

5.2 Winterising

- Put the heat pump in “OFF” mode.
- Cut the power supply to the heat pump.
- Empty the condenser with the help of the drain to avoid any risk of deterioration. (high risk of freezing).
- Close the by-pass valve and unscrew the entry/exit connection unions.
- Eliminate the maximum amount of residual stagnant water from the condenser with the help of an air gun.
- Close the water entry and exit areas of the heating pump to avoid introducing foreign bodies.
- Cover the heating pump with a dedicated winterising case.



Any damage caused by poor winterising maintenance will lead to cancellation of the warranty.

6. APPENDIX

6.1 Electrical diagrams

ECLI15MA / ECLI20MA / ECLI30MA (*)

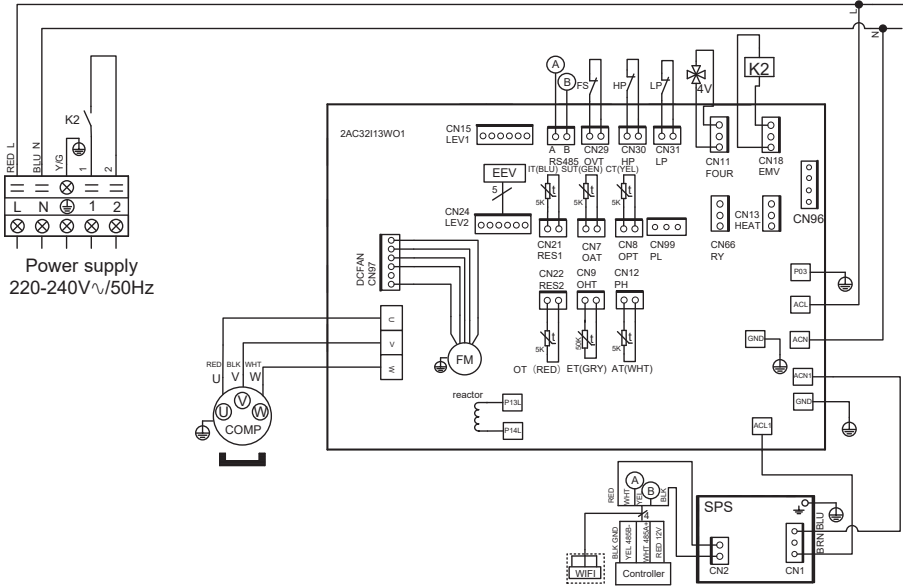

REMARKS

- | | |
|--|---|
| AT : AIR TEMPERATURE SENSOR | LP : LOW PRESSURE SWITCH |
| COMP : COMPRESSOR | OT : OUTLET WATER TEMPERATURE SENSOR |
| CT : EVAPORATOR TEMPERATURE SENSOR | SUT : SUCTION TEMPERATURE SENSOR |
| EEV : ELECTRONIC EXPANSION VALVE | 4V : 4 WAYS VALVE |
| FM : FAN MOTOR | K2 : DRY CONTACT 16 A MAX |
| FS : WATER FLOW SWITCH | ET : DISCHARGE TEMPERATURE SENSOR |
| HP : HIGH PRESSURE SWITCH | --- : OPTION |
| IT : WATER INLET TEMPERATURE SENSOR | |

(*) Check the machine references on the conversion table (see label on the cover of the manual).

6. APPENDIX (continued)

ECLI40MA (*)

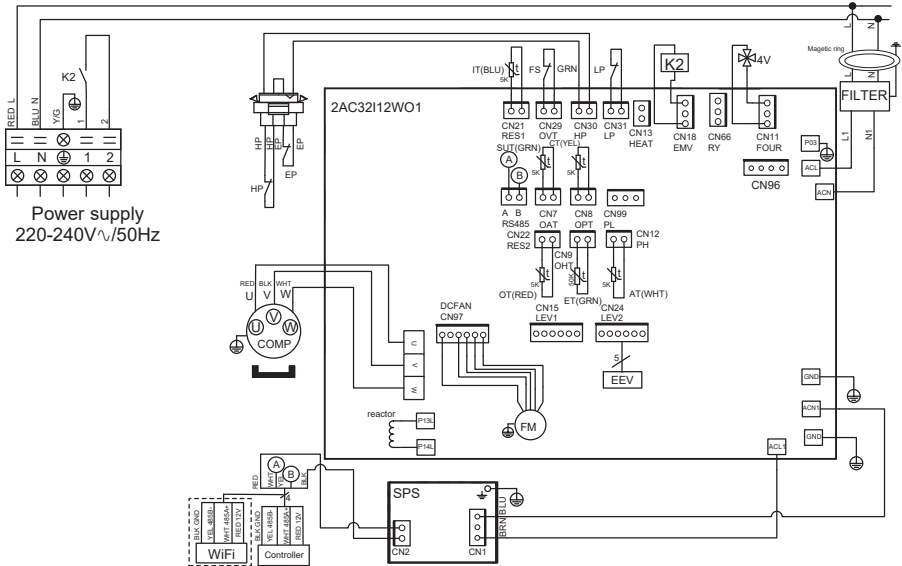

REMARKS

- | | |
|--|---|
| AT : AIR TEMPERATURE SENSOR | LP : LOW PRESSURE SWITCH |
| COMP : COMPRESSOR | OT : OUTLET WATER TEMPERATURE SENSOR |
| CT : EVAPORATOR TEMPERATURE SENSOR | SUT : SUCTION TEMPERATURE SENSOR |
| EEV : ELECTRONIC EXPANSION VALVE | 4V : 4 WAYS VALVE |
| FM : FAN MOTOR | K2 : DRY CONTACT 16 A MAX |
| FS : WATER FLOW SWITCH | ET : DISCHARGE TEMPERATURE SENSOR |
| HP : HIGH PRESSURE SWITCH | --- : OPTION |
| IT : WATER INLET TEMPERATURE SENSOR | |

(*) Check the machine references on the conversion table (see label on the cover of the manual).

6. APPENDIX (continued)

6.2 Heating priority wiring for monophasic pump

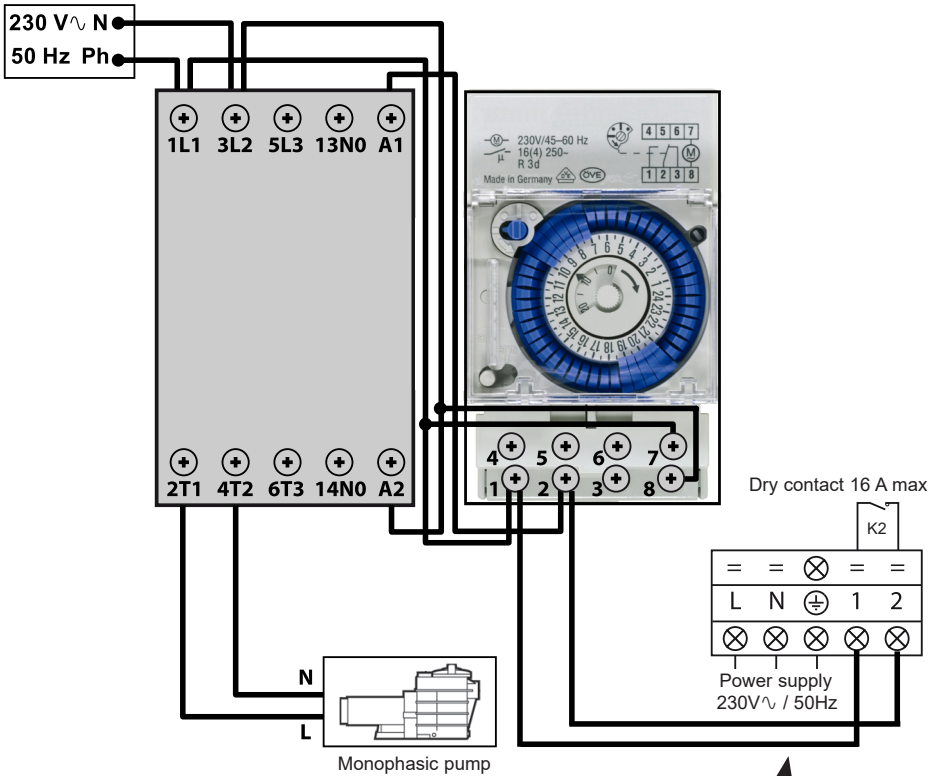

Terminals 1 and 2 deliver a potential-free dry contact, 230V \sim / 50 Hz, no polarity.

Wire terminals 1 and 2 as indicated in the diagram above, to activate the operation of the filtration pump in 2-minute cycles each hour if the temperature of the pool is lower than the set point.

 Never connect the power supply of the filtration pump directly to terminals 1 and 2.



Page left intentionally blank

6. APPENDIX (continued)

6.3 Exploded view and spare parts / Addendum

ECLI15MA / 20MA / 30MA / 40MA (*)

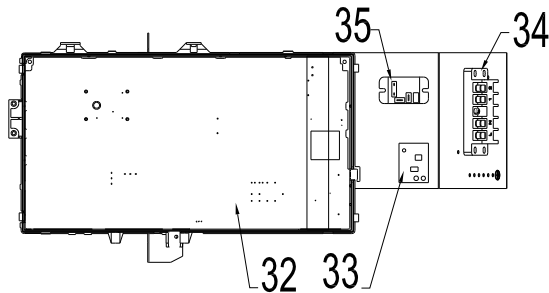
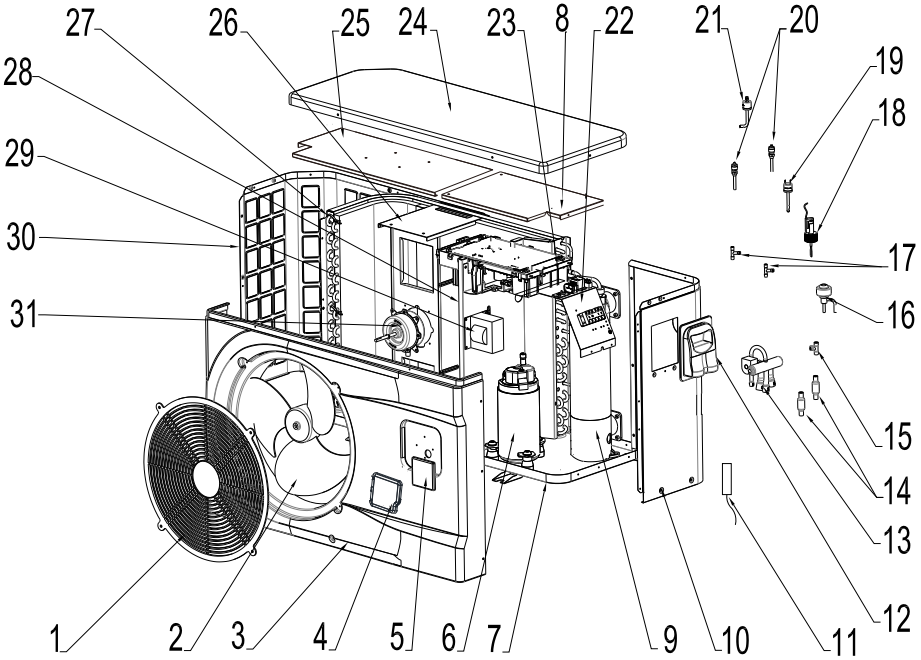

6. APPENDIX (continued)

Mark	Description	Ref.	ECLI15MA*	ECLI20MA*	ECLI30MA*	ECLI40MA*
1	Fan protection grille	HWX20000220245	✓	✓	✓	n/a
		HWX20000220369	n/a	n/a	n/a	✓
2	Fan blade	HWX301030000006	✓	✓	✓	n/a
		HWX301030000001	n/a	n/a	n/a	✓
3	Front panel	HWX809000099	✓	✓	✓	n/a
		HWX809001100	n/a	n/a	n/a	✓
4	Smoked Protection cover	HWX809000320	✓	✓	✓	✓
5	LED Controller	HWX82300038	✓	✓	✓	✓
6	Compressor	HWX20000110448	✓	✓	✓	n/a
	Compressor	HWX80100003	n/a	n/a	n/a	✓
7	/	/	/	/	/	/
8	/	/	/	/	/	/
9	Titanium/PVC condenser	HWX80600037	✓	n/a	n/a	n/a
		HWX32012120061	n/a	✓	n/a	n/a
		HWX32012120056	n/a	n/a	✓	n/a
		HWX806000096	n/a	n/a	n/a	✓
10	Right panel	HWX80700445	✓	✓	✓	n/a
		HWX80700314	n/a	n/a	n/a	✓
11	Compressor aspiration sensor 5k-560mm	HWX83000044	✓	✓	✓	n/a
	Compressor aspiration sensor 5k-760mm	HWX83000053	n/a	n/a	n/a	✓
	Ambiente temp sensor 5k-350mm	HWX83000049	✓	✓	✓	✓
	Water outlet sensor 5k-410mm	HWX83000050	✓	✓	✓	✓
	Water inlet sensor 5k-850mm	HWX83000052	✓	✓	✓	✓
	Compressor Discharge probe 50k-660mm	HWX83000026	✓	✓	✓	✓
	De-icing sensor 5k-680mm	HWX83000051	✓	✓	✓	n/a
	De-icing sensor 5k-1040mm	HWX83000045	n/a	n/a	n/a	✓
12	Access hatch	HWX320922029	✓	✓	✓	✓
13	4 ways valve	HWX20041437	✓	✓	✓	✓
14	Filter ø9.7-ø9.7 (Ø19)	HWX20000140178	✓	✓	✓	n/a
	Filter ø9.7-ø9.7 (Ø28)	HWX20041444	n/a	n/a	n/a	✓
15	T connector ø9.52-2 x ø6.35(T) x 1.0	HWX30403000002	✓	✓	✓	✓
16	Electronic expansion valve	HWX20000140570	✓	✓	✓	n/a
		HWX81000013	n/a	n/a	n/a	✓
17	T connector ø6.5-2 x ø6.5(T) x 0.75	HWX20001460	✓	✓	✓	✓
18	Water flow detector	HWX83000012	✓	✓	✓	✓
19	Low pressure switch NO 0.30MPa/0.15MPa	HWX20000360157	✓	✓	✓	✓
20	Pressure Tap 40mm 1/2"	HWX20000140150	✓	✓	✓	✓
21	High pressure switch NC 3.2MPa/4.4MPa	HWX20013605	✓	✓	✓	✓
22	/	/	/	/	/	/
23	/	/	/	/	/	/
24	Top cover	HWX809000055	✓	✓	✓	n/a
		HWX301090200806	n/a	n/a	n/a	✓
25	/	/	/	/	/	/
26	Motor bracket	HWX80700218	✓	✓	✓	n/a
		HWX80700248	n/a	n/a	n/a	✓

(*) Check the machine references on the conversion table (see label on the cover of the manual).

6. APPENDIX (continued)

ECLI15MA / 20MA / 30MA / 40MA (*)

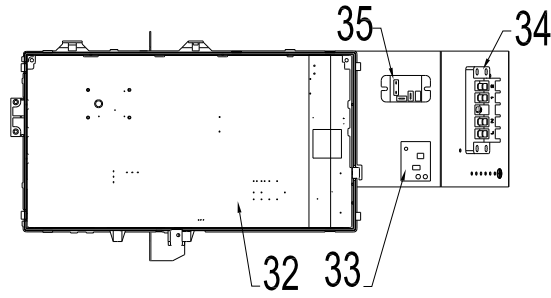
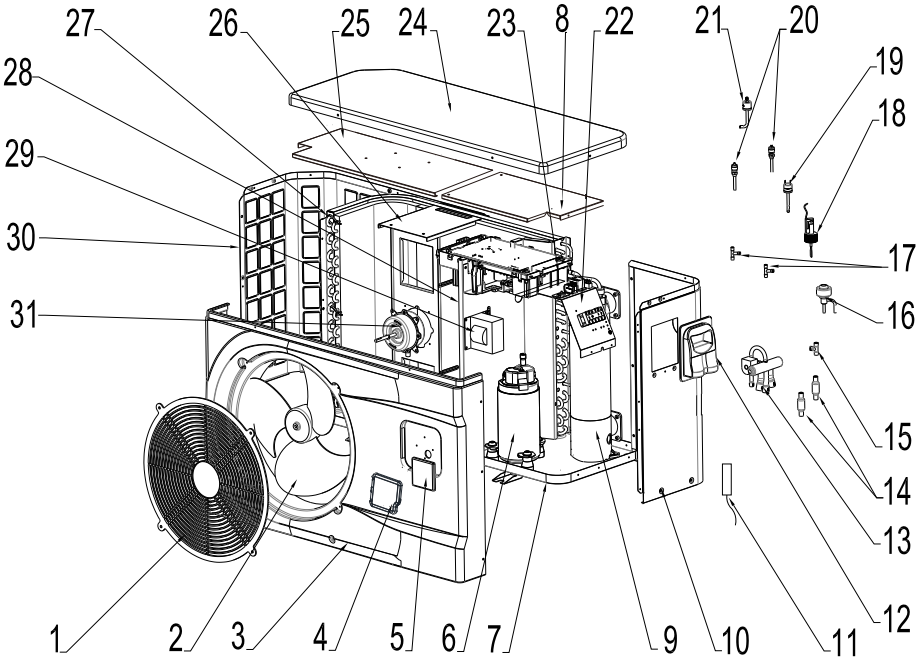

6. APPENDIX (continued)

Mark	Description	Ref.	ECL115MA*	ECL120MA*	ECL130MA*	ECL140MA*
27	Fin coil	HWX301060202502	✓	n/a	n/a	n/a
		HWX80600042	n/a	✓	n/a	n/a
		HWX80600043	n/a	n/a	✓	n/a
		HWX80600044	n/a	n/a	n/a	✓
28	/	/	/	/	/	
29	16A 50Hz 5mH coil	HWX82500006	✓	✓	✓	n/a
	20A 50Hz 5.2mH coil	HWX82500005	n/a	n/a	n/a	✓
30	Left panel	HWX80700446	✓	✓	✓	n/a
		HWX80700315	n/a	n/a	n/a	✓
		HWX80200018	✓	✓	✓	n/a
31	DC ventilator motor	HWX20000330132	n/a	n/a	n/a	✓
		HWX82300052	✓	✓	✓	n/a
32	Printed circuit board Driver	HWX82300007	n/a	n/a	n/a	✓
		HWX82600008	✓	✓	✓	✓
33	230V~/12VDC transformer	HWX82600008	✓	✓	✓	✓
34	Terminal block L-N-GND -5 connections 4mm ²	HWX40003901	✓	✓	✓	✓
35	K2 relay	HWX20000360297	✓	✓	✓	✓

(*) Check the machine references on the conversion table (see label on the cover of the manual).

6. APPENDIX (continued)

6.4 Troubleshooting guide



Certain operations must be carried out by an authorized technician.

If a fault occurs on the heat pump ⚠ appears in the top left-hand corner of the screen.

Refer to following table.



When the problem is resolved, the error is automatically acknowledged and the triangle disappears.

- To delete the error list, press on **Del**.
- Press 2 times on **○** to return to the main screen.

6. APPENDIX (continued)

Problem	Error codes	Description	Solution
Water inlet sensor fault	P01	The sensor is open or has short-circuited.	Verify the CN21/RES1 connectors on the board and the extension connector or replace the sensor
Water outlet sensor fault	P02		Verify the N22/RES2 connectors on the board and the extension connector or replace the sensor
Outside temperature sensor fault	P04		Verify the CN12/PH connectors on the board and the extension connector or replace the sensor
De-icing sensor fault	P05		Verify the CN8/OPT connectors on the board and the extension connector or replace the sensor
Compressor aspiration sensor defect	P07		Verify the CN7/OAT connectors on the board and the extension connector or replace the sensor
Compressor discharge sensor fault	P081		Verify the CN9/OHT connectors on the board and the extension connector or replace the sensor
High pressure protection	E01	The sensor is open or has short-circuited.	Verify the CN30/HP connectors on the card or replace the sensor Check the water flow Check the water flow detector Check the valve opening Check the by-pass Check the evaporator is not clogged Water temperature too hot Incondensable problem after maintenance, empty and evacuate the cooling circuit Fluid load too high, remove fluid into a liquid bottle
Low pressure protection	E02	The sensor is open or has short-circuited.	Check the AI/DI03 connections on the card or replace the sensor Large coolant leak, search for the leak with the detector Air flow too low, check the ventilator rotation speed Check the evaporator is not clogged, clean its surface
Flow sensor fault	E03	The sensor is open or has short-circuited.	Check the AI/DI02 connections on the card or replace the sensor Lack of water, check the filtration pump operation Check the stop valve opening Check the by-pass adjustment

6. APPENDIX (continued)

Problem	Error codes	Description	Solution
Input/Output temperature difference > 13°C	E06	Applicable in Cold mode only	Lack of water, check the filtration pump operation
			Check the stop valve opening
			Check the by-pass adjustment
Antifreeze protection Cold mode	E07	Water output temperature < 4°C	Stop the heat pump, empty the condenser risk of freezing
Communication problem	E08	No communication between the printed circuit board and the user interface	Check the connectors - see the wiring diagram
Level 1 antifreeze protection	E19	2° < Water temperature < 4° and Air temperature < 0°	Stop heat pump operation, empty the condenser to avoid freezing, by default the heat pump starts the filtration pump to avoid icing over
Level 2 antifreeze protection	E29	Water temperature < 2° and Air temperature < 0°	Stop heat pump operation, empty the condenser to avoid freezing, by default the heat pump starts the filtration pump and the heat pump to avoid icing over.
Fan motor fault	F031	Motor jammed or faulty connection	Check free rotation; check CN97/DC connectors; replace the motor
Fan motor fault	F051	Faulty connection	Check the DCFAN/CN97 connector; replace the motor
Exterior temperature too low	TP	Operating limit reached	Stop the heat pump

6. APPENDIX (continued)

6.5 Warranty

WARRANTY CONDITIONS

All HAYWARD products are guaranteed to be free from manufacturing or material faults for a period of two years as from the date of purchase. Any claim made under the terms of the warranty must be accompanied by a dated proof of purchase. We therefore recommend that you keep your invoice.

The HAYWARD warranty is limited to the repair or replacement, at HAYWARD's discretion, of faulty products, provided they have been used under normal conditions, as described in their user guide, and that the product has not been modified in any way and has been used only with HAYWARD components and parts. Frost and chemical damage are not covered.

No other costs (transportation, labour, etc.) are covered by the warranty.

HAYWARD cannot be held liable for any direct or indirect damage caused by the incorrect installation, connection or operation of a product.

Please contact your retailer if you want to make a claim under the terms of the warranty and request the repair or replacement of an item. No equipment returned to our factory will be accepted without our prior written agreement.

Worn parts are not covered by the warranty.

Page left intentionally blank

FULL INVERTER R32

UNIDAD DE BOMBA DE CALOR PARA PISCINAS

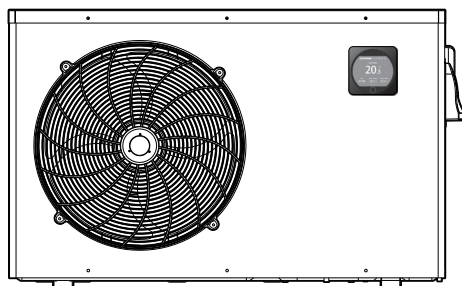

Manual de Instalación e Instrucciones

ÍNDICE

1. PREFACIO	1
2. CARACTERÍSTICAS TÉCNICAS	4
2.1 Datos técnicos de la bomba de calor	4
2.2 Margen de funcionamiento	5
2.3 Dimensiones	6
3. INSTALACIÓN Y CONEXIÓN	7
3.1 Esquema eléctrico	7
3.2 Bomba de calor	7
3.3 Conexión hidráulica	8
3.4 Conexión eléctrica	9
3.5 Primer arranque	10
3.6 Ajuste del caudal de agua	12
4. INTERFAZ USUARIO	13
4.1 Presentación general	13
4.2 Ajuste de la fecha y de la hora	15
4.3 Ajuste de los temporizadores Marcha/Parada	16
4.4 Ajuste y visualización del punto de referencia	18
4.5 Apertura y bloqueo automático de la pantalla táctil	19
4.6 Ajuste del modo silencioso	20
5. MANTENIMIENTO E INVIERNO	23
5.1 Mantenimiento	23
5.2 Invierno	23
6. ANEXOS	24
6.1 Esquemas eléctricos	24
6.2 Conexiones con prioridad al calentador de bomba monofásico	26
6.3 Despiece y piezas de recambio / Addendum	28
6.4 Guía de reparación	32
6.5 Garantía	35

Leer atentamente y conservar para consultar con posterioridad.

Este documento debe suministrarse al propietario de la piscina y debe ser conservado por éste en un lugar seguro.

1. PREFACIO

Le agradecemos la compra de esta bomba de calor de piscina Hayward. La bomba de calor Hayward FULL INVERTER ha sido diseñada según normas estrictas de fabricación para satisfacer los más altos niveles de calidad requeridos.

Las bombas de calor Hayward le ofrecerán excepcionales prestaciones a todo lo largo de su temporada de baños, adaptando la potencia, el consumo eléctrico y el nivel sonoro a la necesidad de calentamiento de su piscina gracias a la lógica de control FULL INVERTER.



Lea atentamente las consignas de este manual antes de utilizar el aparato.

Las bombas de calor Hayward están exclusivamente destinadas a calentar el agua de la piscina, no utilizar este material para otros fines.

El presente manual incluye todas las informaciones necesarias referentes a la instalación, la eliminación de los disfuncionamientos y el mantenimiento.

Lea atentamente este manual antes de abrir la unidad o de realizar operaciones de mantenimiento en la misma. En ningún caso, el fabricante del producto será responsable en caso de lesiones de un usuario o de daño de la unidad debido a eventuales errores de instalación, de eliminación de disfuncionamientos o de un mantenimiento inadecuado. Es primordial seguir en todo momento las instrucciones especificadas en este manual.

El no respeto de cualquier recomendación anula la garantía.

1. PREFACIO (continuación)



Consignas de seguridad



Este aparato contiene R32.

Nunca utilizar otro refrigerante que no sea el R32. Cualquier otro cuerpo gaseoso mezclado con el R32 corre el riesgo de provocar presiones anormalmente elevadas que pueden ocasionar una avería o una ruptura de tubos y lesionar personas.

En las reparaciones u operaciones de mantenimiento, nunca utilizar tubos de cobre de un espesor inferior a 0,8 mm.

Como la bomba de calor está a presión, nunca perforar los tubos ni intentar hacer una soldadura. Hay riesgo de explosión.

Nunca exponer el aparato a llamas, chispas ni otras fuentes de encendido. Podría explosionar y ocasionar lesiones graves, incluso mortales.

- En caso de almacenamiento, la bomba de calor se debe almacenar en una habitación bien ventilada y con una superficie de más de A_{\min} (m²) dada por la siguiente fórmula: $A_{\min} = (M / (2,5 \times 0,22759 \times h_0))^2$
M es la carga de refrigerante en el aparato en kg y h₀ es la altura de almacenamiento. Para almacenar sobre el suelo h₀ = 0,6 m.
- La bomba de calor está exclusivamente prevista para instalar al exterior de edificios.
- La unidad debe ser instalada por un personal calificado.
- No instalar la bomba de calor sobre un soporte que pueda amplificar las vibraciones de la unidad.
- Verificar que el soporte previsto para la unidad está correctamente dimensionado para el peso del aparato.
- No instalar la bomba de calor en un lugar que pueda amplificar su nivel sonoro o en un lugar donde el ruido de la unidad pueda molestar a los vecinos.
- Todas las conexiones eléctricas deben ser efectuadas por un electricista profesional calificado y según las normas vigentes en el país de instalación, ver § 3.4.
- Cortar la aplicación principal y el seccionador antes de cualquier trabajo eléctrico. Todo olvido puede causar electrocución.
- Antes de la instalación, verificar que el cable de tierra no está cortado ni desconectado.

1. PREFACIO (continuación)

- Conectar y apretar convenientemente el cable de alimentación eléctrica. Si la conexión es incorrecta, las partes eléctricas se pueden dañar.
- La exposición de la bomba de calor al agua o a un medio húmedo puede provocar una electrocución. Esté muy vigilante.
- Si detecta cualquier defecto o situación anormal, no instale la bomba de calor y contacte inmediatamente con su revendedor.
- El mantenimiento y las diferentes operaciones se deben realizar a la frecuencia y en los momentos recomendados, como se especifica en el presente manual.
- Las reparaciones deben ser efectuadas por un personal calificado.
- Solo utilice piezas de recambio originales.
- Nunca utilizar otro procedimiento de limpieza que no sea el recomendado en este manual.

Informaciones importantes referentes al refrigerante utilizado.

Este producto contiene gases fluorados de efecto invernadero enmarcados por el protocolo de Kioto. No libere estos gases a la atmósfera.

Tipo de refrigerante: R32

Valor GWP(1): 675, valor basado en el 4to informe del IPCC.

La cantidad de refrigerante basada en el reglamento n.º 517/2014 (F-Gas) se indica en la placa de características de la unidad.

En función de la legislación europea o local, se pueden exigir inspecciones periódicas de fuga del refrigerante. Contacte con su distribuidor local para más informaciones.

(1) Potencial de calentamiento global

2. CARACTERÍSTICAS TÉCNICAS

2.1 Datos técnicos de la bomba de calor

Modelos	CLÁSICO FULL INVERTER	ECL115MA(*)	ECL120MA(*)	ECL130MA(*)	ECL140MA(*)
Tensión de alimentación	V	220 V-240 V ~ / monofásica / 50 Hz			
Refrigerante	/	R32			
Carga	kg	0,350	0,430	0,480	0,650
Masa en tCO ₂ eq	/	0,24	0,29	0,32	0,44
Frecuencia de control de fuga	/	Ninguna exigencia, pero se recomienda una vez al año			
Capacidad de calentamiento Mín--Máx ^(a)	kW	1,62--7,33	2,18--8,97	1,97 --11,66	2,85--17,06
Potencia eléctrica absorbida Mín--Máx ^(a)	kW	0,15--1,17	0,17--1,54	0,16--1,99	0,26--3,13
Corriente nominal de servicio Mín--Máx ^(a)	A	1,15--5,32	1,27--6,91	1,08--8,96	1,41--13,69
COP Máx--Mín (a)	/	11,04--6,30	12,77--5,81	12,57--5,84	11,08--5,45
Capacidad de calentamiento Mín--Máx ^(b)	kW	1,44--5,36	1,58--6,94	1,79--8,62	2,74--13,08
Potencia eléctrica absorbida Mín--Máx ^(b)	kW	0,24--1,14	0,27--1,53	0,290--1,90	0,428--2,97
COP Máx--Mín ^(b)	/	5,98--4,69	5,82--4,53	6,17--4,52	6,40--4,40
Corriente máxima de servicio (CMS)	A	6,4	8,4	10,9	16,6
Calibre del fusible	aM	8	10	16	20
Disyuntor curva D	D	8	10	16	20
Intensidad por arranque	A	< CMS			
Conexión hidráulica	mm	50mm			
Caudal nominal de agua (a)	m ³ /h	3,10	3,80	4,90	7,30
Pérdida de carga máxima en el agua	kPa	2,3	2,9	6,4	6,7
Compresor	/	DC Inverter Mitsubishi			DC Inverter Highly
Tipo	/	Rotativo doble			Rotativo doble
Cantidad	/	1			
Resistencia de enrollado a 20°C	Ohmio	1,91			0,788
Ventilador	/	Axial			
Cantidad	/	1			
Diámetro	mm	405			510
Cantidad de aletas	/	3			
Motor	/	Inversor CD			
Cantidad	/	1			
Velocidad de rotación	rpm	600--700	600--800	850--950	600--850
Velocidad modo silencio	rpm	400	400	400	300
Nivel de presión acústica a 1 m	dB(A)	35	43	43	46
Nivel de presión acústica a 10m	dB(A)	18	25	25	29
Dimensiones netas de la unidad (longitud-ancho-altura)	mm	1040 / 425 / 615			1130 / 460 / 780
Masa	kg	42	45	46	60

(*) Verifique las referencias de la máquina utilizando la tabla de correspondencias (ver etiqueta en la cubierta del manual).



(a) Aire seco 27°C - Humedad relativa 78% - Temperatura de entrada del agua 26°C.

(b) Aire seco 15°C - Humedad relativa 71% - Temperatura de entrada del agua 26°C.

2. CARACTERÍSTICAS TÉCNICAS (continuación)

2.2 Margen de funcionamiento

Utilizar la bomba de calor dentro de los siguientes márgenes de temperatura y de humedad para garantizar un funcionamiento seguro y eficaz.

	Modo calentamiento 	Modo enfriamiento 
Temperatura exterior	-7°C – +35°C	+7°C – +43°C
Temperatura del agua	+12°C – +32°C	+8°C – +40°C
Humedad relativa	< 80%	< 80%
Margen de reglaje del punto de referencia	+15°C – +32°C	+8°C – +32°C



Si la temperatura o la humedad no corresponden a estas condiciones, los dispositivos de seguridad pueden activarse y la bomba de calor puede no funcionar.



La temperatura máxima de calentamiento está limitada a 32°C para evitar el deterioro de los revestimientos. Hayward no se hace responsable en el caso de un uso por encima de +32°C.

2. CARACTERÍSTICAS TÉCNICAS (continuación)

2.3 Dimensiones

Modelos:

ECLI15MA / ECLI20MA / ECLI30MA*

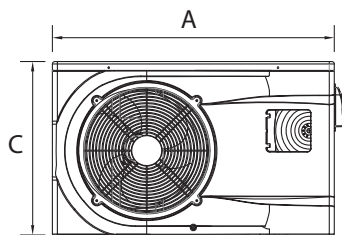
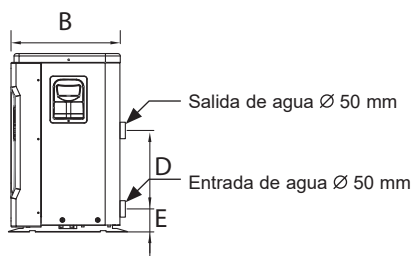

ECLI40MA*

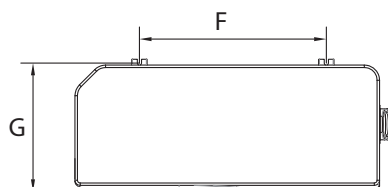
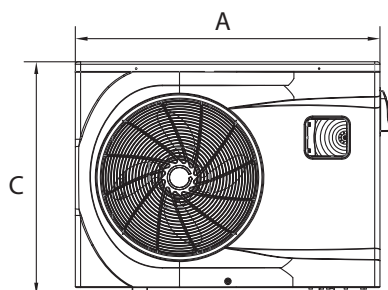
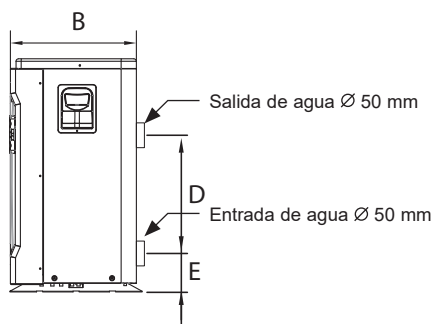

Unidad : mm

Modelo(*)	ECLI15MA / ECLI20MA / ECLI30MA	ECLI40MA
Referencia		
A	956	1002
B	360	415
C	605	767
D	350	350
E	98	101
F	545	615
G	380	442

(*) Verifique las referencias de la máquina utilizando la tabla de correspondencias (ver etiqueta en la cubierta del manual).

3. INSTALACIÓN Y CONEXIÓN

3.1 Esquema eléctrico

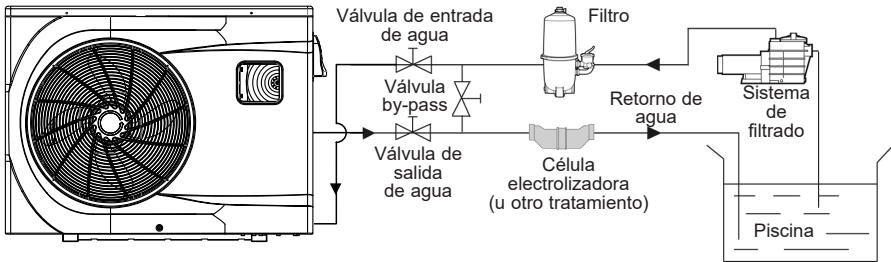

Nota: La bomba de calor se suministra sin ningún equipo de tratamiento o filtración. Los elementos que aparecen en el esquema son las piezas que deberá proporcionar el instalador.

3.2 Bomba de calor



Colocar la bomba de calor en el exterior y fuera de cualquier sala técnica cerrado.

Colocar en una zona resguarda, las distancias mínimas que a continuación se prescriben deben ser respetadas a fin de evitar cualquier riesgo de recirculación del aire y de una degradación del rendimiento global de la bomba de calor.

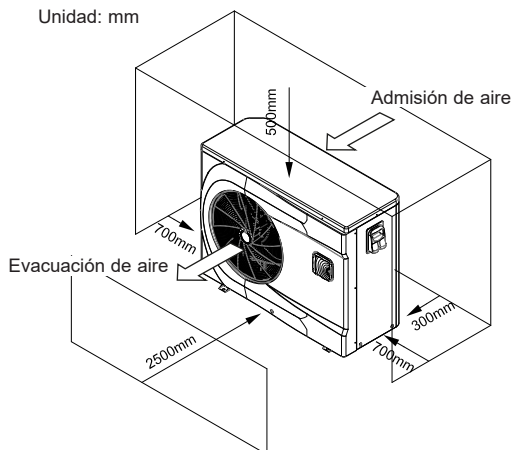

3. INSTALACIÓN Y CONEXIÓN (continuación)



Preferiblemente instale la bomba de calor sobre una superficie de hormigón aislada o una silla de fijación prevista a tal fin y monte la bomba de calor sobre los silentblocs suministrados (los tornillos y arandelas no se suministran).

Distancia máxima de instalación entre la bomba de calor y la piscina 15 metros.

Longitud total de ida-vuelta de las canalizaciones hidráulicas 30 metros.

Aislar las canalizaciones hidráulicas de superficie y enterradas.

La bomba de calor debe instalarse a una distancia mínima de la piscina en cumplimiento de la NF C 15-100 (es decir a 3,5 m de la piscina para Francia) o según las normas de instalación vigentes en el resto de países.

No instalar la bomba de calor cerca de una fuente de calor.

En caso de instalación en regiones nevosas, se recomienda poner la máquina a resguardo para evitar una acumulación de nieve sobre el evaporador.

3.3 Conexión hidráulica

La bomba de calor se suministra con dos conexiones de unión de 50 mm de diámetro. Utilice un tubo de PVC para la canalización hidráulica Ø 50 mm. Conecte la entrada de agua de la bomba de calor al conducto proveniente del grupo de filtración, tras esto conecte la salida de agua de la bomba de calor al conducto de agua que va a la piscina (cf esquema de abajo).

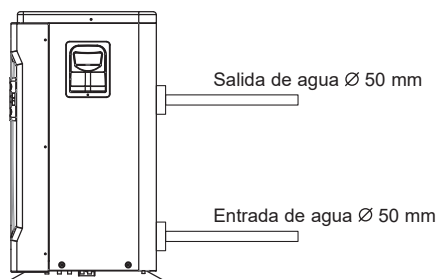

Instale una válvula "by-pass" entre la entrada y la salida de la bomba de calor.



Si se utiliza un distribuidor automático o un electrolizador, se debe instalar obligatoriamente después de la bomba de calor con el fin de proteger el condensador de titanio de una concentración demasiado grande de producto químico.



Se ruega instale la válvula by-pass y las conexiones de unión suministradas al nivel de la entrada y la salida de agua de la unidad, con el fin de simplificar la purga durante el periodo invernal y de facilitar el acceso o el desmontaje para el mantenimiento.

3. INSTALACIÓN Y CONEXIÓN (continuación)

3.4 Conexión eléctrica



La instalación eléctrica y el cableado de este equipo debe cumplir con la normativa de instalación local en vigor.

F	NF C15-100	GB	BS7671:1992
D	DIN VDE 0100-702	EW	EVHS-HD 384-7-702
A	ÖVE 8001-4-702	H	MSZ 2364-702/1994/MSZ 10-553 1/1990
E	UNE 20460-7-702 1993, RECBT ITC-BT-31 2002	M	MSA HD 384-7-702.S2
IRL	Wiring Rules + IS HD 384-7-702	PL	PN-IEC 60364-7-702:1999
I	CEI 64-8/7	CZ	CSN 33 2000 7-702
LUX	384-7.702 S2	SK	STN 33 2000-7-702
NL	NEN 1010-7-702	SLO	SIST HD 384-7-702.S2
P	RSIUEE	TR	TS IEC 60364-7-702



Compruebe que la alimentación eléctrica disponible y la frecuencia de la red corresponden con la corriente de funcionamiento requerida, teniendo en consideración el emplazamiento específico del aparato y la corriente necesaria para alimentar cualquier otro aparato que esté conectado al mismo circuito.

ECLI15MA / ECLI20MA / ECLI30MA / ECLI40MA(*)
230V ~ +/- 10 % 50 Hz 1 Fase

Observe el esquema de cableado correspondiente en el anexo. La caja de conexiones se encuentra en el lado derecho de la unidad. Hay tres conexiones destinadas a la alimentación eléctrica y dos para el control del sistema de filtrado (servomecanismo).

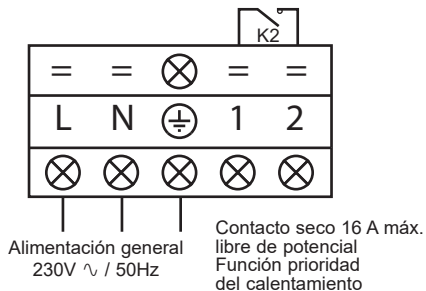

(*) Verifique las referencias de la máquina utilizando la tabla de correspondencias (ver etiqueta en la cubierta del manual).

3. INSTALACIÓN Y CONEXIÓN (continuación)



La línea de alimentación eléctrica debe estar dotada, de manera apropiada, de un dispositivo de protección del tipo fusible de acompañamiento del motor (aM) o disyuntor curva D, así como de un disyuntor diferencial 30mA (ver tabla a continuación).

Modelos		ECLI15MA(*)	ECLI20MA(*)	ECLI30MA(*)	ECLI40MA(*)
Alimentación eléctrica	V/Ph/Hz	230V~ 50Hz	230V~ 50Hz	230V~ 50Hz	230V~ 50Hz
Calibre de fusible tipo aM	A	8 aM	10 aM	16 aM	20 aM
Disyuntor curva D	A	8 D	10 D	16 D	20 D
Sección de cable	mm ²	3G 2,5	3G 2,5	3G 2,5	3G 4

(*) Verifique las referencias de la máquina utilizando la tabla de correspondencias (ver etiqueta en la cubierta del manual).



Use un cable de alimentación de tipo RO 2 V / R 2 V o equivalente.



Las secciones de cable indicadas se corresponden a una longitud máxima de 25 m. Sin embargo, deben comprobarse y adaptarse en función de las condiciones de instalación.



Tenga siempre cuidado de detener la alimentación principal antes de abrir la caja de control eléctrico.

3.5 Primer arranque

Procedimiento de arranque - una vez que se ha terminado la instalación, siga y respete las siguientes etapas:

- 1) Gire los ventiladores con la mano para comprobar que pueden girar libremente y que la hélice está correctamente fijada al árbol del motor.
- 2) Asegúrese de que la unidad está conectada correctamente a la alimentación principal (ver el esquema de cableado en el anexo).
- 3) Active el sistema de filtrado.
- 4) Verifique que todas las válvulas de agua están abiertas y que el agua circula hacia la unidad antes de pasar al modo de calentamiento o enfriamiento.
- 5) Verifique que la acometida de purga de condensados está fijada correctamente y no presenta ninguna obstrucción.
- 6) Activar la alimentación eléctrica destinada a la unidad, después presione el botón de Marcha/Parada  sobre el panel de control.

3. INSTALACIÓN Y CONEXIÓN (continuación)

- 7) Cerciórese de que no se visualicen los símbolos de alarma o de bloqueo. Dado el caso, ver la guía de reparación (ver § 6.4).
- 8) Fije el caudal de agua con la ayuda de la válvula by-pass (ver § 3.6 y 2.1), tal y como se prevee respectivamente para cada modelo de manera que obtenga una diferencia de temperatura Entrada/ Salida de 2°C.
- 9) Tras estar funcionando unos cuantos minutos, verifique que el aire sale de la unidad y se enfría (entre 5 y 10°).
- 10) Estando la unidad en servicio, desactive el sistema de filtrado. La unidad debe pararse automáticamente y mostrar el código de error E03.
- 11) Haga funcionar la unidad y la bomba de la piscina durante 24 horas seguidas, hasta que se alcance la temperatura del agua deseada. Cuando la temperatura de entrada del agua alcance el valor de referencia, la unidad se para. Se pone en funcionamiento de nuevo automáticamente (siempre que la bomba de la piscina esté en servicio) si la temperatura desciende menos de 0,5°C por debajo de la temperatura de referencia.

Controlador del caudal - La unidad está dotada de un controlador de caudal que activa la bomba de calor mientras el sistema de filtrado de la piscina está en servicio y la desactiva cuando el sistema de filtrado está fuera de servicio. Por falta de agua, el código de alarma E03 aparece en el reguador (Ver § 6.4).

Temporización - la unidad integra una temporización de 3 minutos, que tiene por objeto proteger los componentes del circuito de control, eliminar cualquier inestabilidad en el arranque y cualquier interferencia del contactor. Por medio de esta temporización, la unidad arranca de nuevo automáticamente unos 3 minutos después de que se produzca un corte del circuito de control. Incluso un corte de corriente de corta duración activa la temporización de arranque.

3. INSTALACIÓN Y CONEXIÓN (continuación)

3.6 Ajuste del caudal de agua

Con las válvulas de entrada y salida de agua abiertas, ajustar la válvula "by-pass" de forma que se obtenga una diferencia de 2°C entre la temperatura de entrada y de la salida del agua (ver el esquema eléctrico § 3.1). Puede verificar el ajuste visualizando las temperaturas de entrada/salida directamente sobre el panel de control.



Nota: La apertura de la válvula "by-pass" genera un caudal menor, lo cual conlleva un aumento de ΔT .

El cierre de la válvula "by-pass" genera un caudal mayor, lo cual conlleva una disminución de ΔT .

4. INTERFAZ USUARIO

4.1 Presentación general

La bomba de calor está equipada con un panel de control digital con pantalla táctil, el cual ha sido previamente conectado eléctricamente y programado en fábrica para funcionar en modo calentamiento.

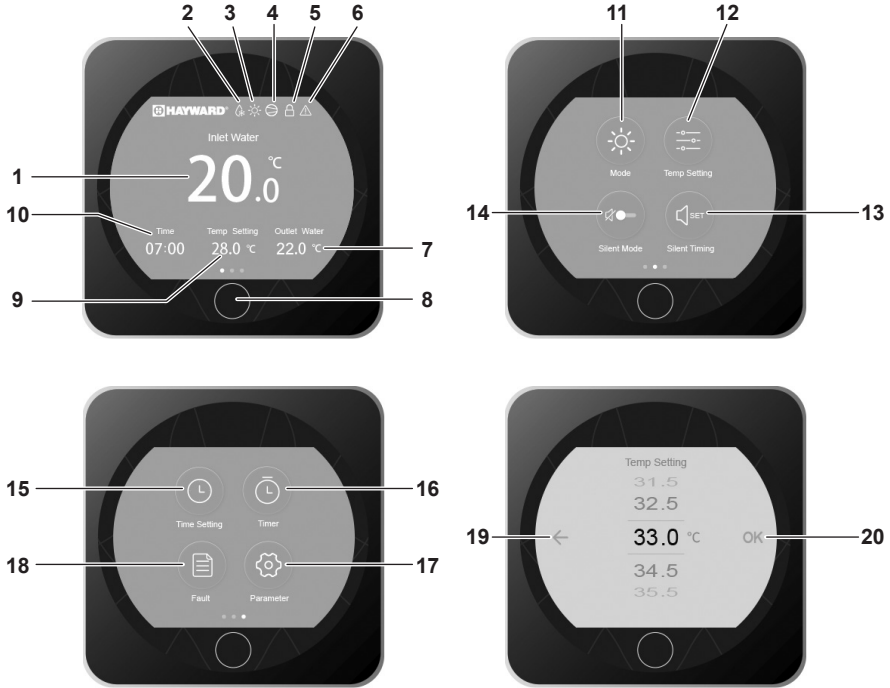

Leyenda

1	Temperatura de entrada del agua
2	Modo deshielo
3	Modo de funcionamiento
4	Indicador luminoso de marcha del compresor
5	Bloqueo de la pantalla
6	Alarma
7	Temperatura de salida del agua
8	Marcha/Parada/Retorno
9	Temperatura de consigna
10	Tiempo

11	Selección del modo de funcionamiento
12	Regulación del punto de consigna
13	Ajuste del temporizador en modo silencioso
14	Activación del modo silencio
15	Regulación de la fecha y la hora
16	Regulación Temporizadores Marcha/Parada
17	Acceso a los parámetros avanzados
18	Acceso a la lista de defectos
19	Retorno (sin validación)
20	Validación

4. INTERFAZ USUARIO (continuación)

Modo OFF/PARADA

Cuando la bomba de calor está parada (en espera), aparece la inscripción OFF, como se indica en la pantalla.

La pantalla negra indica que la bomba de calor está parada, es posible ajustar los parámetros en este modo.



Modo ON/MARCHA

Cuando la bomba de calor está en funcionamiento o en regulación (se alcanza el punto de consigna), la pantalla pasa a azul.





Para pasar del modo OFF al modo ON y viceversa, pulsar el botón .

4. INTERFAZ USUARIO (continuación)

4.2 Ajuste de la fecha y de la hora

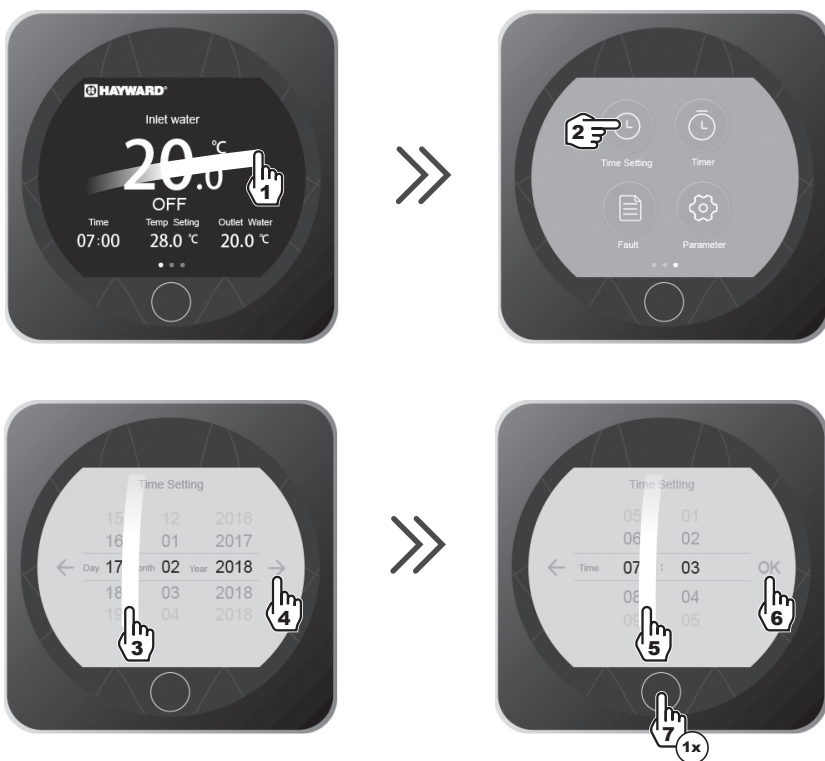
El ajuste de la fecha y de la hora se puede hacer indistintamente en modo ON u OFF.



- Pulsar 1 veces  para volver a la pantalla principal.

4. INTERFAZ USUARIO (continuación)

4.3 Ajuste de los temporizadores Marcha/Parada

El ajuste de esta función será necesario cuando usted desee hacer funcionar su bomba de calor durante un periodo de tiempo más corto que el determinado por el reloj de filtración. De esta forma podrá programar un arranque retardado y una parada anticipada o simplemente prohibir un periodo horario de funcionamiento (por ejemplo la noche)..

Tiene la posibilidad de programar un temporizador de Marcha y un temporizador de Parada. El paso de ajuste es «de hora en hora».



4. INTERFAZ USUARIO (continuación)



Resaltado en azul = Activado
Gris = Desactivado

- Pulsar 2 veces  para volver a la pantalla principal.

4. INTERFAZ USUARIO (continuación)

4.4 Ajuste y visualización del punto de referencia

El ajuste del punto de consigna se efectúa indistintamente en modo ON o en modo OFF con una precisión de 0,5°C.



- Pulsar 1 vez  para volver a la pantalla principal.



Se recomienda no sobrepasar jamás la temperatura de 30°C para evitar la alteración de los liners.

4. INTERFAZ USUARIO (continuación)

4.5 Apertura y bloqueo automático de la pantalla táctil

El bloqueo y desbloqueo de la pantalla se pueden hacer indistintamente en modo ON o en modo OFF.



Bloqueo activado



Bloqueo desactivado

4. INTERFAZ USUARIO (continuación)

4.6 Ajuste del modo silencioso

El modo silencioso permite usar la bomba de calor en modo ahorro y de forma muy silenciosa cuando las necesidades de calentamiento son bajas (para mantener la temperatura de la piscina o en caso de necesitar un funcionamiento ultrasilencioso).

Esta función se puede Activar / Desactivar manualmente o con un temporizador.

Activación / Desactivación



Modo silencio desactivado



Modo silencioso activado



- Pulsar 1 vez  para volver a la pantalla principal.

4. INTERFAZ USUARIO (continuación)

Ajuste del temporizador del modo SILENCIO



4. INTERFAZ USUARIO (continuación)



- Pulsar 2 veces  para volver a la pantalla principal.



El paso de ajuste es «de hora en hora».

Una vez que el temporizador esté activado, permanecerá activo los 7 días de la semana.

5. MANTENIMIENTO E INVIERNO

5.1 Mantenimiento

Estas operaciones de mantenimiento deben realizarse 1 vez al año con el fin de garantizar la longevidad y el buen funcionamiento de la bomba de calor.

- Limpie el evaporador con un cepillo flexible o de un chorro de aire o agua (**Atención no utilizar jamás un limpiador de alta presión**).
- Verifique el buen flujo de los condensados.
- Compruebe la fijación de las conexiones hidráulicas y eléctricas
- Compruebe la estanqueidad hidráulica del condensador.
- **Un profesional autorizado** deberá comprobar la estanqueidad del circuito frigorífico con un detector de fugas.



Antes de realizar cualquier operación de mantenimiento, la bomba de calor debe estar desconectada de cualquier fuente de corriente eléctrica. Las operaciones de mantenimiento deben ser realizadas únicamente por personal cualificado y capacitado para manipular fluidos frigorígenos.

5.2 Invierno

- Poner la bomba de calor en Modo "OFF".
- Cortar la alimentación de la bomba de calor.
- Vaciar el condensador a través del desagüe para evitar cualquier riesgo de degradación. (riesgo importante de congelación).
- Cerrar la válvula "by-pass" y desatornillar las conexiones de unión entrada/salida.
- Expulse toda el agua estancada residual del condensador ayudándose con una pistola de aire.
- Obture la entrada y la salida de agua a la bomba de calor para evitar la intrusión de cuerpos extraños.
- Cubrir la bomba de calor con una funda de protección para el invierno.



Cualquier daño ocasionado por un mal mantenimiento invernal conlleva la anulación de la garantía.

6. ANEXOS

6.1 Esquemas eléctricos

ECLI15MA / ECLI20MA / ECLI30MA (*)

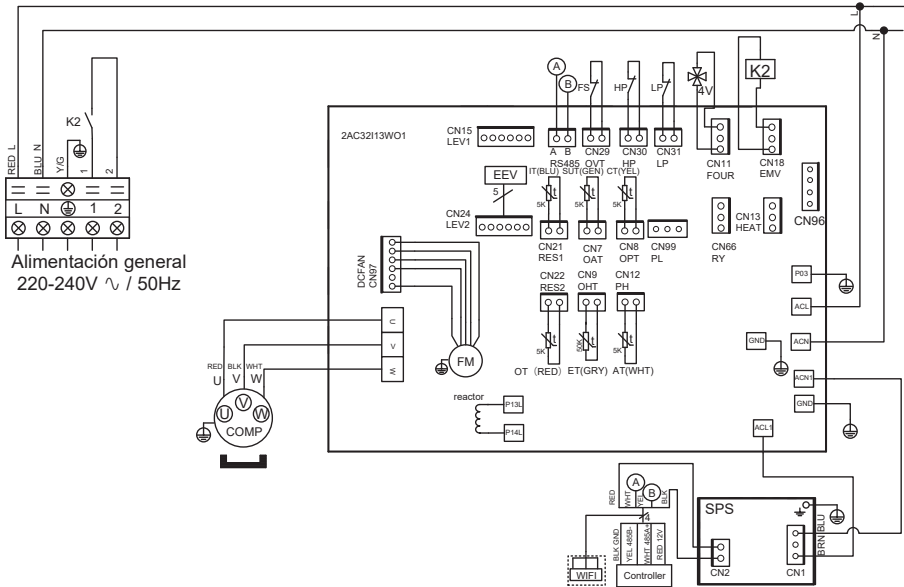

LEYENDA

- | | |
|---|--|
| AT : Sonda de temperatura de aire | LP : Presostato baja presión |
| COMP : Compresor | OT : Onda de temperatura de entrada de agua |
| CT : Sonda de temperatura evaporador | SUT : Sonda de temperatura de aspiración |
| EEV : Descompresor electrónico | 4V : Válvula 4 vías |
| FM : Motor ventilador | K2 : Contacto seco libre de 16 A máx. |
| FS : Detector de presencia de agua | ET : Sonda de temperatura de descarga |
| HP : Presostato alta presión | --- Opción |
| IT : Sonda de temperatura de entrada de agua | |

(*) Verifique las referencias de la máquina utilizando la tabla de correspondencias (ver etiqueta en la cubierta del manual).

6. ANEXOS (continuación)

ECLI40MA (*)

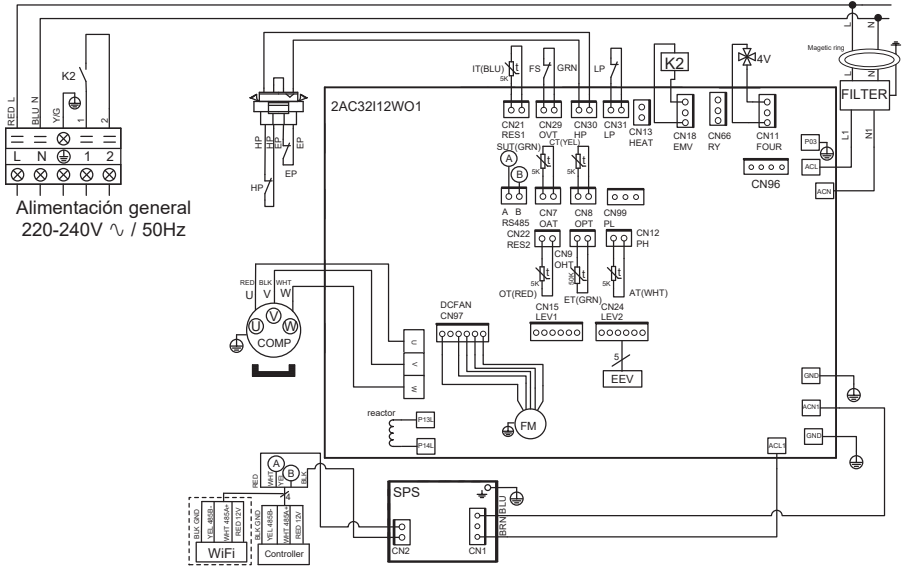

LEYENDA

- | | |
|---|--|
| AT : Sonda de temperatura de aire | LP : Presostato baja presión |
| COMP : Compresor | OT : Onda de temperatura de entrada de agua |
| CT : Sonda de temperatura evaporador | SUT : Sonda de temperatura de aspiración |
| EEV : Descompresor electrónico | 4V : Válvula 4 vías |
| FM : Motor ventilador | K2 : Contacto seco libre de 16 a máx. |
| FS : Detector de presencia de agua | ET : Sonda de temperatura de descarga |
| HP : Presostato alta presión | [] : Opción |
| IT : Sonda de temperatura de entrada de agua | |

(*) Verifique las referencias de la máquina utilizando la tabla de correspondencias (ver etiqueta en la cubierta del manual).

6. ANEXOS (continuación)

6.2 Conexiones con prioridad al calentador de bomba monofásico

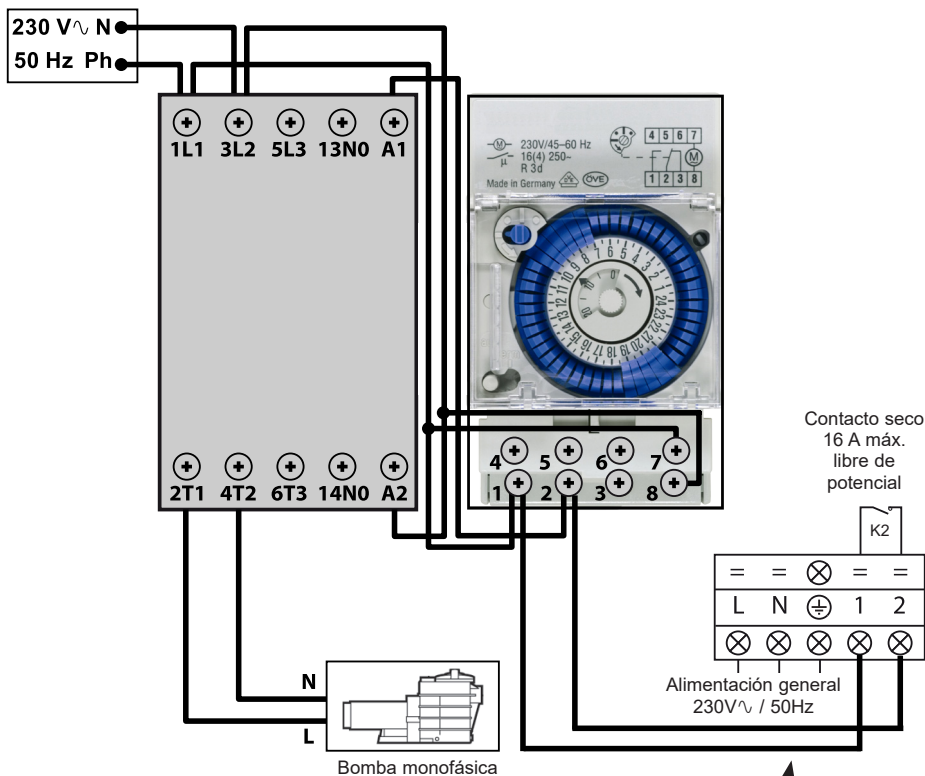

Los bornes 1 et 2 suministran un contacto seco (libre de potencial), sin polaridad de 230 V \sim / 50 Hz.

Conecte los cables a los bornes 1 y 2 respetando el esquema de cableado que se indica a continuación para que la bomba de filtración funcione por ciclos de 2 min cada hora en caso de que la temperatura de la piscina sea inferior al punto de consigna.

 No conecte nunca la alimentación de la bomba de filtración directamente a los bornes 1 y 2.



Página en blanco intencionalmente

6. ANEXOS (continuación)

6.3 Despiece y piezas de recambio / Addendum

ECLI15MA / 20MA / 30MA / 40MA (*)

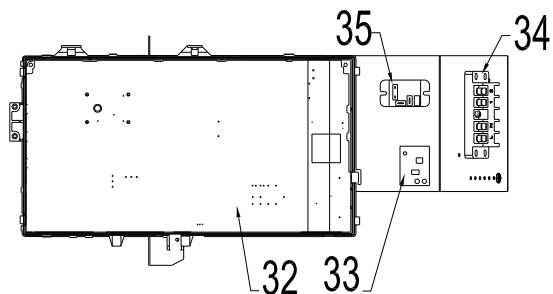
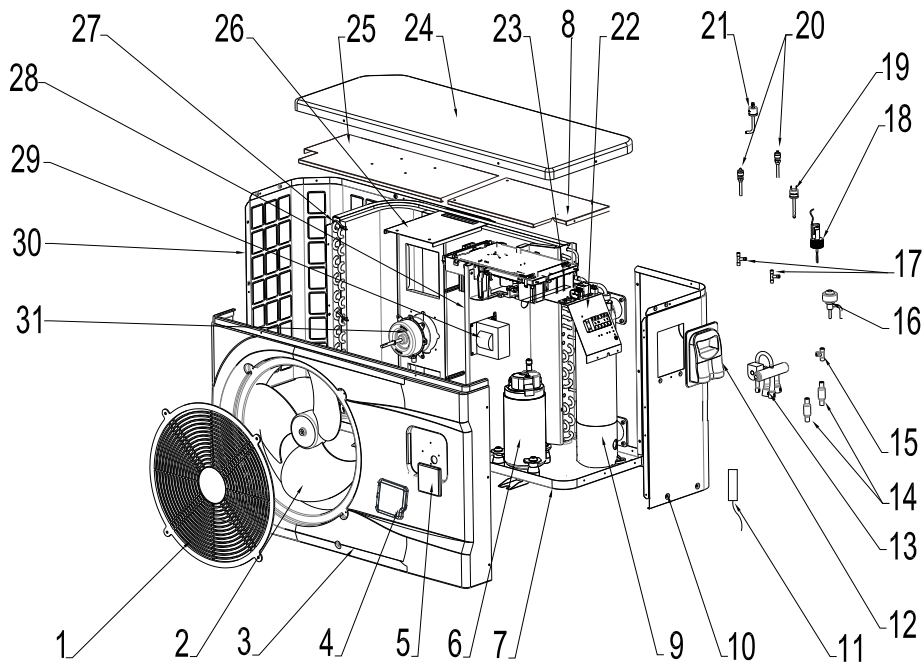

6. ANEXOS (continuación)

Rep	Designación	Ref.	ECLI15MA*	ECLI20MA*	ECLI30MA*	ECLI40MA*
1	Rejilla de protección del ventilador	HWX20000220245	✓	✓	✓	n/a
		HWX20000220369	n/a	n/a	n/a	✓
2	Hélice ventilador	HWX301030000006	✓	✓	✓	n/a
		HWX301030000001	n/a	n/a	n/a	✓
3	Panel delantero	HWX809000099	✓	✓	✓	n/a
		HWX809001100	n/a	n/a	n/a	✓
4	Puerta de protección	HWX809000320	✓	✓	✓	✓
5	Regulador LED	HWX82300038	✓	✓	✓	✓
6	Compresor	HWX20000110448	✓	✓	✓	n/a
	Compresor	HWX80100003	n/a	n/a	n/a	✓
7	/	/	/	/	/	/
8	/	/	/	/	/	/
9	Condensador de titanio/PVC	HWX80600037	✓	n/a	n/a	n/a
		HWX32012120061	n/a	✓	n/a	n/a
		HWX32012120056	n/a	n/a	✓	n/a
		HWX806000096	n/a	n/a	n/a	✓
10	Panel derecho	HWX80700445	✓	✓	✓	n/a
		HWX80700314	n/a	n/a	n/a	✓
11	Sonda de aspiración compresor 5k-560mm	HWX83000044	✓	✓	✓	n/a
	Sonda de aspiración compresor 5k-760mm	HWX83000053	n/a	n/a	n/a	✓
	Sonda de temperatura de aire 5k-350mm	HWX83000049	✓	✓	✓	✓
	Sonda de salida de agua 5k-410mm	HWX83000050	✓	✓	✓	✓
	Sonda de entrada de agua 5k-850mm	HWX83000052	✓	✓	✓	✓
	Sonda de descarga compresor 50k-660mm	HWX83000026	✓	✓	✓	✓
	Sonda de descongelación 5k-680mm	HWX83000051	✓	✓	✓	n/a
Sonda de descongelación 5k-1040mm	HWX83000045	n/a	n/a	n/a	✓	
12	Trampilla de acceso eléctrico	HWX320922029	✓	✓	✓	✓
13	Válvula 4 vías	HWX20041437	✓	✓	✓	✓
14	Filtro ø9.7-ø9.7 (Ø19)	HWX20000140178	✓	✓	✓	n/a
	Filtro ø9.7-ø9.7 (Ø28)	HWX20041444	n/a	n/a	n/a	✓
15	Conector en T ø9.52-2 x ø6.35(T) x 1.0	HWX30403000002	✓	✓	✓	✓
16	Descompresor electrónico	HWX20000140570	✓	✓	✓	n/a
		HWX81000013	n/a	n/a	n/a	✓
17	Conector en T ø6.5-2 x ø6.5(T) x 0.75	HWX20001460	✓	✓	✓	✓
18	Detector del caudal de agua	HWX83000012	✓	✓	✓	✓
19	Presostato baja presión NO 0.30MPa/0.15MPa	HWX20000360157	✓	✓	✓	✓
20	Toma de presión 40mm-1/2"	HWX20000140150	✓	✓	✓	✓
21	Presostato de alta presión NC 3.2MPa/4.4MPa	HWX20013605	✓	✓	✓	✓
22	/	/	/	/	/	/
23	/	/	/	/	/	/
24	Panel superior	HWX809000055	✓	✓	✓	n/a
		HWX301090200806	n/a	n/a	n/a	✓
25	/	/	/	/	/	/
26	Soporte del motor	HWX80700218	✓	✓	✓	n/a
		HWX80700248	n/a	n/a	n/a	✓

(*) Verifique las referencias de la máquina utilizando la tabla de correspondencias (ver etiqueta en la cubierta del manual).

6. ANEXOS (continuación)

ECLI15MA / 20MA / 30MA / 40MA (*)

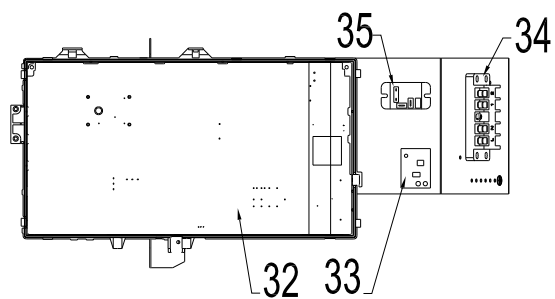
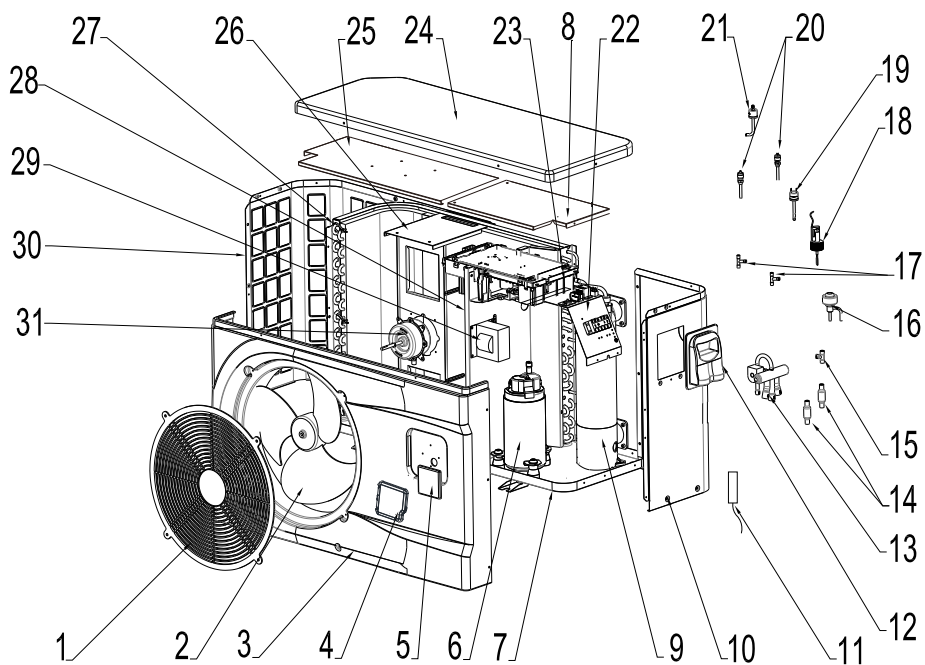

6. ANEXOS (continuación)

Rep	Designación	Ref.	ECL15MA*	ECL20MA*	ECL30MA*	ECL40MA*
27	Evaporador de aleta	HWX301060202502	✓	n/a	n/a	n/a
		HWX80600042	n/a	✓	n/a	n/a
		HWX80600043	n/a	n/a	✓	n/a
		HWX80600044	n/a	n/a	n/a	✓
28	/	/	/	/	/	
29	Bobina 16A 50Hz 5mH	HWX82500006	✓	✓	✓	n/a
	Bobina 20A 50Hz 5.2mH	HWX82500005	n/a	n/a	n/a	✓
30	Panel de la izquierda	HWX80700446	✓	✓	✓	n/a
		HWX80700315	n/a	n/a	n/a	✓
31	Motor ventilador CC	HWX80200018	✓	✓	✓	n/a
		HWX20000330132	n/a	n/a	n/a	✓
32	Tarjeta electrónica Driver	HWX82300052	✓	✓	✓	n/a
		HWX82300007	n/a	n/a	n/a	✓
33	Transformador 230V~/12DC	HWX82600008	✓	✓	✓	✓
34	Borna L-N-GND -5 conexiones 4mm ²	HWX40003901	✓	✓	✓	✓
35	Relé K2	HWX20000360297	✓	✓	✓	✓

(*) Verifique las referencias de la máquina utilizando la tabla de correspondencias (ver etiqueta en la cubierta del manual).

6. ANEXOS (continuación)

6.4 Guía de reparación





Algunas operaciones deben ser realizadas por un técnico habilitado.

En caso de defecto en la bomba de calor, aparece el símbolo  en el ángulo superior izquierdo de la pantalla.

Consulte la tabla siguiente.



Después de resolver el problema y de haberse solucionado automáticamente, desaparece el triángulo.

- Para borrar la lista de errores, pulsar .
- Pulsar 2 veces  para volver a la pantalla principal.

6. ANEXOS (continuación)

Fallo	Códigos de error	Descripción	Solución
Fallo de la sonda de entrada de agua	P01	El sensor está abierto o presenta un cortocircuito.	Verificar la conexión CN21/RES1 en la tarjeta y el conector prolongación o reemplazar el captador
Fallo de la sonda de salida de agua	P02		Verificar la conexión N22/RES2 en la tarjeta y el conector prolongación o reemplazar el captador
Fallo de la sonda de temperatura exterior	P04		Verificar la conexión CN12/PH en la tarjeta y el conector prolongación o reemplazar el captador
Fallo de la sonda de descongelación	P05		Verificar la conexión CN8/OPT en la tarjeta y el conector prolongación o reemplazar el captador
Fallo de la sonda de aspiración del compresor	P07		Verificar la conexión CN7/OAT en la tarjeta y el conector prolongación o reemplazar el captador
Fallo de la sonda de recirculación del compresor	P081		Verificar la conexión CN9/OHT en la tarjeta y el conector prolongación o reemplazar el captador
Protección alta presión	E01	El sensor está abierto o presenta un cortocircuito.	<p>Verificar la conexión CN30/HP en la tarjeta o sustituir el sensor</p> <p>Comprobar el caudal de agua</p> <p>Comprobar el detector del flujo de agua</p> <p>Comprobar la apertura de las válvulas</p> <p>Comprobar el by-pass</p> <p>Comprobar el estado de suciedad del evaporador</p> <p>Temperatura del agua demasiado caliente</p> <p>En caso de problema de incondensables tras un mantenimiento, vaciar y eliminar la humedad del circuito frigorífico</p> <p>Carga de fluido demasiado importante, retirar fluido en una botella de líquido</p>
Protección baja presión	E02	El sensor está abierto o presenta un cortocircuito.	<p>Comprobar la conexión AI/DI03 en la tarjeta o sustituir el sensor</p> <p>Fuga importante de fluido frigorígeno, buscar la fuga con el detector</p> <p>Caudal de aire demasiado bajo, comprobar la velocidad de rotación del ventilador</p> <p>Comprobar el estado de suciedad del evaporador, limpiar la superficie</p>
Fallo del detector de caudal	E03	El sensor está abierto o presenta un cortocircuito.	<p>Comprobar la conexión AI/DI02 en la tarjeta o sustituir el sensor</p> <p>Falta de agua, comprobar el funcionamiento de la bomba de filtración</p> <p>Comprobar la apertura de las válvulas de parada</p> <p>Comprobar el ajuste del by-pass</p>

6. ANEXOS (continuación)

Fallo	Códigos de error	Descripción	Solución
Diferencia de temperatura Entrada/ Salida > 13 °C	E06	Aplicable en modo frío solamente	Falta de agua, comprobar el funcionamiento de la bomba de filtración
			Comprobar la apertura de las válvulas de parada
			Comprobar el ajuste del by-pass
Protección anticongelante Modo frío	E07	Temperatura de salida del agua < a 4 °C	Detener la bomba de calor, vaciar el condensador de riesgo de heladas
Problema de comunicación	E08	No hay comunicación entre la tarjeta electrónica y la interfaz usuario	Verificar las conexiones y la conéctica - ver esquema eléctrico
Protección anticongelante de nivel 1	E19	2° < temperatura del agua < 4° y temperatura del aire < 0°	Detener el funcionamiento de la bomba de calor, vaciar el condensador para evitar las heladas. De forma predeterminada, la bomba de calor activará la bomba de filtración y la bomba de calor para evitar la formación de hielo.
Protección anticongelante de nivel 2	E29	Temperatura del agua < 2° y temperatura del aire < 0°	Detener el funcionamiento de la bomba de calor, vaciar el condensador para evitar las heladas. De forma predeterminada, la bomba de calor activará la bomba de filtración y la bomba de calor para evitar la formación de hielo.
Defecto del motor del ventilador	F031	Motor bloqueado o defecto de conexión	Verificar la rotación libre y la conéctica CN97/DCFan, reemplazar el motor
Defecto del motor del ventilador	F051	Defecto de conexión	Verificar la conéctica DCFAN/CN97, reemplazar el motor
Temperatura exterior demasiado baja	TP	Límite de funcionamiento alcanzado	Parar la bomba de calor

6. ANEXOS (continuación)

6.5 Garantía

CONDICIONES DE GARANTÍA

Todos los productos HAYWARD están garantizados contra defectos de fabricación y material durante dos años a partir de la fecha de compra. Toda reclamación de garantía debe ir acompañada de una prueba de compra que justifique la fecha. A tal efecto, asegúrese de conservar su factura.

La garantía de HAYWARD se limita a la reparación o sustitución, a elección de HAYWARD, de los productos defectuosos, siempre que se hayan usado en condiciones normales, conforme a las recomendaciones e instrucciones del manual de uso, que no hayan sido objeto de modificación alguna y se hayan utilizado únicamente con componentes y piezas de HAYWARD. Los daños provocados por congelación y agentes químicos no están cubiertos por la garantía.

Todos los demás gastos (transporte, mano de obra, etc.) quedan excluidos de la garantía.

HAYWARD declina toda responsabilidad derivada de daños directos o indirectos causados por una instalación, una conexión o un uso incorrecto del producto.

Para usar la garantía y solicitar la reparación o sustitución de un artículo, póngase en contacto con su distribuidor. No se aceptarán envíos de material a nuestra fábrica sin nuestra aceptación previa por escrito.

Las piezas de desgaste no están cubiertas por la garantía.

Página en blanco intencionalmente

FULL INVERTER R32

BOMBA DE AQUECIMENTO PARA PISCINAS

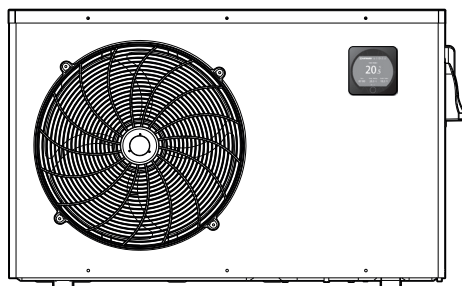

Manual de instalação e de instruções

RESUMO

1. PREFÁCIO	1
2. CARACTERÍSTICAS TÉCNICAS	4
2.1 Dados técnicos da bomba de aquecimento	4
2.2 Período de funcionamento	5
2.3 Dimensões	6
3. INSTALAÇÃO E LIGAÇÃO	7
3.1 Esquema de princípio	7
3.2 Bomba de aquecimento	7
3.3 Ligação hidráulica	8
3.4 Ligação eléctrica	9
3.5 Primeira colocação em serviço	10
3.6 Ajuste do débito de água	12
4. INTERFACE DO UTILIZADOR	13
4.1 Apresentação geral	13
4.2 Configuração de data e hora	15
4.3 Ajuste dos Temporizadores Funcionamento/Paragem	16
4.4 Ajuste do ponto de instrução	18
4.5 Bloqueio e libertação do ecrã táctil	19
4.6 Ajustamento do modo SILÊNCIO	20
5. MANUTENÇÃO E PREPARAÇÃO PARA O INVERNO	23
5.1 Manutenção	23
5.2 Preparação para o Inverno	23
6. ANEXOS	24
6.1 Esquemas eléctricos	24
6.2 Ligações prioridade aquecimento bomba monofásica	26
6.3 Vistas explodidas e peças sobressalentes / Addendum	28
6.4 Guia de resolução de avarias	32
6.5 Garantia	35

Ler atentamente e conservar para consulta posterior.

Este documento deve ser entregue ao proprietário da piscina e deve ser conservado por este em local seguro.

1. PREFÁCIO

Agradecemos-lhe pela compra desta bomba de calor para piscina Hayward. A bomba de calor Hayward FULL INVERTER foi concebida segundo estritas normas de fabrico para satisfazer os mais elevados níveis de qualidade requeridos.

As bombas de calor Hayward oferecem-lhe desempenhos excecionais ao longo de toda a época de utilização da sua piscina, adaptando a potência, o consumo elétrico e o nível sonoro à sua necessidade de aquecimento, graças à lógica de controlo FULL INVERTER.



Leia atentamente as instruções deste manual antes de utilizar o aparelho.

As bombas de calor Hayward são exclusivamente destinadas a aquecer a água da piscina, não utilizar este material para outros fins.

O presente manual inclui todas as informações necessárias sobre a instalação, a eliminação de falhas de funcionamento e a conservação.

Leia atentamente este manual antes de abrir a unidade, ou realizar nesta operações de manutenção. O fabricante deste produto não será em caso algum responsável em caso de ferimento de um utilizador ou de deterioração da unidade consecutivos a eventuais erros aquando da instalação, da eliminação de falhas ou de uma manutenção inútil. É fundamental seguir em todas as ocasiões as instruções especificadas neste manual.

Toda recomendação não respeitada anula a garantia.

1. PREFÁCIO (continuação)



Instruções de segurança



Este aparelho contém R32.

Jamais utilizar um refrigerante diferente do R32. A mistura de qualquer outro elemento gasoso com o R32 pode provocar pressões anormalmente elevadas, suscetíveis de provocar uma avaria ou a rutura de tubos e possíveis ferimentos de pessoas.

Aquando de reparações ou de operações de manutenção, nunca utilizar tubos de cobre cuja espessura seja inferior a 0,8 mm.

A bomba de calor está sob pressão, portanto jamais perfurar os tubos nem tentar efetuar uma brasagem. Há um risco de explosão.

Nunca expor o aparelho a chamas, faíscas ou qualquer outra fonte de ignição. Este poderia explodir e causar ferimentos graves ou mesmo mortais.

- Em caso de armazenamento da bomba de calor, esta deve ser armazenada num local corretamente ventilado que tenha uma superfície no solo superior a A_{\min} (m²), estabelecida pela seguinte fórmula: $A_{\min} = (M/(2,5 \times 0,22759 \times h_0))^2$ M sendo a carga de refrigerante no aparelho em kg e h₀ a altura de armazenamento. Para um armazenamento no solo h₀ = 0,6 m.
- A bomba de calor foi exclusivamente prevista para uma instalação ao exterior dos edifícios.
- A unidade deve ser instalada por pessoal qualificado.
- Não instalar a bomba de calor sobre um suporte suscetível de amplificar as vibrações da unidade.
- Verificar que o suporte previsto para a unidade foi adequadamente dimensionado para o peso do aparelho.
- Não instalar a bomba de calor num lugar suscetível de amplificar o seu nível sonoro ou num lugar onde o ruído da unidade possa incomodar a vizinhança.
- Todas as ligações elétricas devem ser efetuadas por um electricista profissional qualificado e de acordo com as normas em vigor no país de instalação, ver § 3.4.
- Cortar a alimentação principal e o seccionador antes de qualquer trabalho elétrico. Qualquer esquecimento pode ser causa de eletrocussão.
- Antes da instalação, verificar que o cabo de ligação à terra não foi cortado ou desconetado.

1. PREFÁCIO (continuação)

- Conetar e apertar adequadamente o cabo de alimentação elétrica. Se a ligação for incorreta, partes elétricas podem ser danificadas.
- A exposição da bomba de calor à água ou a um ambiente húmido pode provocar uma eletrocussão. Mantenha-se extremamente vigilante.
- Se detetar qualquer defeito ou situação anormal, não instale a bomba de calor e contate imediatamente o seu revendedor.
- A manutenção e as diferentes operações devem ser realizadas conforme a frequência e os momentos recomendados, tal como especificado no presente manual.
- As reparações devem ser efetuadas por pessoal qualificado.
- Utilizar somente peças sobressalentes originais.
- Jamais utilizar um outro processo de limpeza que não seja o preconizado neste manual.

Informações importantes relativas ao refrigerante utilizado.

Este produto contém gases fluorados com efeito de estufa que são enquadrados pelo protocolo de Quioto. Não libertar estes gases na atmosfera.

Tipo de refrigerante: R32

Valor GWP(1): 675, Valor baseado no 4º relatório do GIEC.

A quantidade de refrigerante baseada na regulamentação F-Gás n.º 517/2014 está indicada na placa de identificação da unidade.

Inspeções periódicas de fuga de refrigerante podem ser exigidas em função da legislação europeia ou local. Queira contactar o seu distribuidor local para mais amplas informações.

(1) Potencial de aquecimento global

2. CARACTERÍSTICAS TÉCNICAS

2.1 Dados técnicos da bomba de aquecimento

Modelos	CLASSIC FULL INVERTER	ECL115MA(*)	ECL120MA(*)	ECL130MA(*)	ECL140MA(*)
Tensão de alimentação	V	220V-240V ~ / 1fase / 50Hz			
Refrigerante	/	R32			
Carga	kg	0,350	0,430	0,480	0,650
Massa em tCO ₂ eq	/	0,24	0,29	0,32	0,44
Frequência de controle de fuga	/	Nenhuma exigência mas é recomendado que esta seja anual			
Capacidade de aquecimento Mín--Máx ^(a)	kW	1,62--7,33	2,18--8,97	1,97 --11,66	2,85--17,06
Potência elétrica absorvida Mín--Máx ^(a)	kW	0,15--1,17	0,17--1,54	0,16--1,99	0,26--3,13
Corrente nominal de serviço Mín--Máx ^(a)	A	1,15--5,32	1,27--6,91	1,08--8,96	1,41--13,69
COP (coeficiente de desempenho) Máx--Mín ^(a)	/	11,04--6,30	12,77--5,81	12,57--5,84	11,08--5,45
Capacidade de aquecimento Mín--Máx ^(b)	kW	1,44--5,36	1,58--6,94	1,79--8,62	2,74--13,08
Potência elétrica absorvida Mín--Máx ^(b)	kW	0,24--1,14	0,27--1,53	0,290--1,90	0,428--2,97
COP (coeficiente de desempenho) Máx--Mín ^(b)	/	5,98--4,69	5,82--4,53	6,17--4,52	6,40--4,40
Corrente máxima de serviço (CMS)	A	6,4	8,4	10,9	16,6
Calibre do fusível	aM	8	10	16	20
Disjuntor curva D	D	8	10	16	20
Corrente de arranque	A	< CMS			
Ligação hidráulica	mm	50mm			
Caudal de água nominal (a)	m ³ /h	3,10	3,80	4,90	7,30
Perda de carga na água máx	kPa	2,3	2,9	6,4	6,7
Compressor	/	DC Inverter Mitsubishi			DC Inverter Highly
Tipo	/	Duplo Rotativo			Duplo Rotativo
Quantidade	/	1			
Resistência de enrolamento a 20°C	Ohm	1,91			0,788
Ventilador	/	Axial			
Quantidade	/	1			
Diâmetro	mm	405			510
Número de pás	/	3			
Motor	/	DC Inverter			
Quantidade	/	1			
Velocidade de rotação	Rpm	600--700	600--800	850--950	600--850
Velocidade Modo Silêncio	Rpm	400	400	400	300
Nível de pressão acústica a 1 m	dB(A)	35	43	43	46
Nível de pressão acústica a 10m	dB(A)	18	25	25	29
Dimensões (sem embalagem) da unidade (C-L-A)	mm	1040 / 425 / 615			1130 / 460 / 780
Peso	kg	42	45	46	60

(*) Verificar as referências da máquina por meio da tabela de correspondências (ver etiqueta na capa do manual).



(a) Ar seco 27°C - Humidade relativa 78% - Temperatura de entrada da água 26°C.

(b) Ar seco 15°C - Humidade relativa 71% - Temperatura de entrada da água 26°C

2. CARACTERÍSTICAS TÉCNICAS (continuação)

2.2 Período de funcionamento

Utilizar a bomba de aquecimento nos seguintes intervalos de temperatura e humidade para assegurar um funcionamento seguro e eficaz.

	Modo de aquecimento 	Modo de Refrigeração 
Temperatura exterior	-7°C – +35°C	+7°C – +43°C
Temperatura da água	+12°C – +32°C	+8°C – +40°C
Humidade relativa	< 80%	< 80%
Intervalo de Ajuste do ponto de afinação	+15°C – +32°C	+8°C – +32°C



Se a temperatura e a humidade não corresponderem a estas condições, podem disparar os dispositivos de segurança e a bomba de aquecimento pode deixar de funcionar.



A temperatura máxima de aquecimento é limitada à 32°C a fim de evitar a deterioração dos liners. Hayward declina qualquer responsabilidades em caso de utilização que ultrapassa os +32°C.

2. CARACTERÍSTICAS TÉCNICAS (continuação)

2.3 Dimensões

Modelos:

ECLI15MA / ECLI20MA / ECLI30MA*

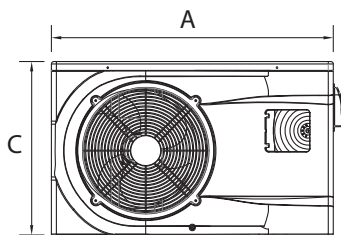
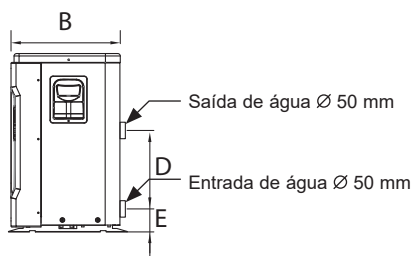

ECLI40MA*

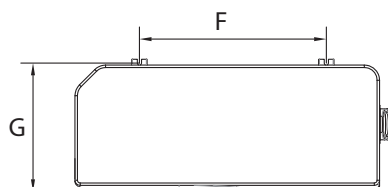
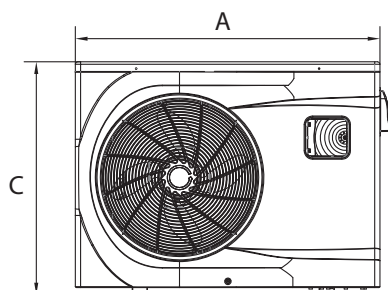
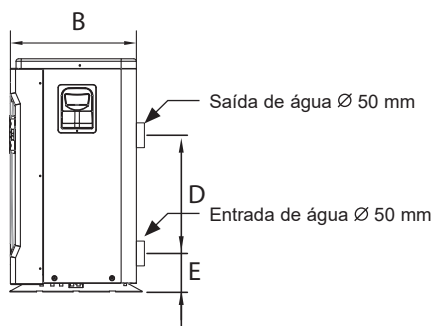

unidade : mm

Referência \ Tipo(*)	ECLI15MA / ECLI20MA / ECLI30MA	ECLI40MA
A	956	1002
B	360	415
C	605	767
D	350	350
E	98	101
F	545	615
G	380	442

(*) Verificar as referências da máquina por meio da tabela de correspondências (ver etiqueta na capa do manual).

3. INSTALAÇÃO E LIGAÇÃO

3.1 Esquema de princípio

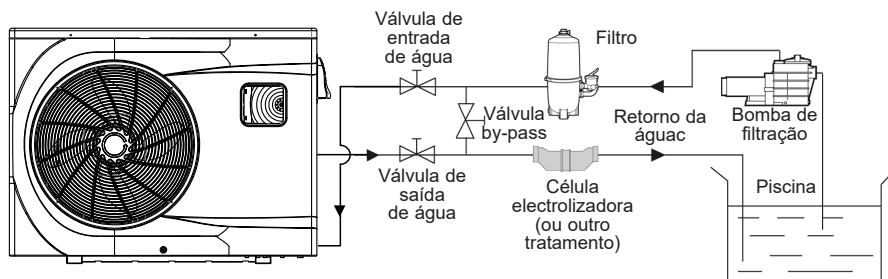

Nota: A bomba de aquecimento é fornecida sem qualquer equipamento de tratamento ou filtração. Os elementos presentes no esquema são peças a fornecer pelo instalador.

3.2 Bomba de aquecimento



Colocar a bomba de aquecimento no exterior e fora de qualquer local técnico fechado.

Colocada sob abrigo, devem ser respeitadas as distâncias mínimas prescritas abaixo a fim de evitar qualquer risco de recirculação de ar e de degradação dos desempenhos globais da bomba de aquecimento.

Unidade : mm

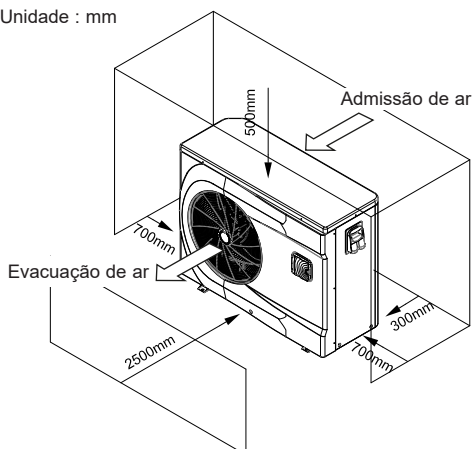

3. INSTALAÇÃO E LIGAÇÃO (continuação)



Instalar de preferência a bomba de calor sobre uma laje de betão dessolidarizada ou uma caixa de fixação prevista para este efeito e montar a bomba de aquecimento sobre os blocos amortecedores fornecidos (parafusos e anilhas não fornecidos).

Distância máxima de instalação entre a bomba de aquecimento e a piscina 15 metros.

Comprimento total ida e volta das canalizações hidráulicas 30 metros.

Isolar as canalizações hidráulicas de superfície e enterradas.

A bomba de calor deve ser instalada a uma distância mínima da piscina de acordo com a norma NF C 15-100 (ou seja, a 3,5 m da massa de água, em França) ou com as normas de instalação em vigor noutros países.

Não instalar a bomba de calor junto a fontes de calor.

Em caso de instalação em regiões com ocorrência de neve, recomenda-se manter a máquina abrigada para evitar a acumulação de neve no evaporador.

3.3 Ligação hidráulica

A bomba de aquecimento é fornecida com duas uniões de 50 mm de diâmetro. Utilizar tubo PVC para canalização hidráulica Ø 50 mm. Ligar a entrada de água da bomba de aquecimento à conduta proveniente do grupo de filtração e, em seguida, ligar a saída de água da bomba de aquecimento à conduta de água que segue para a bacia (consultar esquema abaixo).

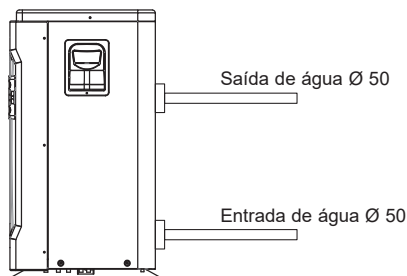

Instalar uma válvula dita de “by-pass” entre a entrada e a saída da bomba de aquecimento.



Se for utilizado um distribuidor automático, deve obrigatoriamente ser instalado após a bomba de aquecimento a fim de proteger o condensador Titane contra uma concentração demasiado elevada de produto químico.



Tenha o cuidado de instalar a bomba de by-pass e as uniões fornecidas ao nível de entrada e saída de água da unidade, a fim de simplificar a purga durante o período de Inverno, facilitar o acesso ou a respectiva desmontagem para manutenção.

3. INSTALAÇÃO E LIGAÇÃO (continuação)

3.4 Ligação eléctrica



A instalação eléctrica e a cablagem deste equipamento devem estar em conformidade com a regras de instalação locais em vigor.

F	NF C15-100	GB	BS7671:1992
D	DIN VDE 0100-702	EW	EVHS-HD 384-7-702
A	ÖVE 8001-4-702	H	MSZ 2364-702/1994/MSZ 10-553 1/1990
E	UNE 20460-7-702 1993, RECBT ITC-BT-31 2002	M	MSA HD 384-7-702.S2
IRL	Regras de cablagem + IS HD 384-7-702	PL	PN-IEC 60364-7-702:1999
I	CEI 64-8/7	CZ	CSN 33 2000 7-702
LUX	384-7.702 S2	SK	STN 33 2000-7-702
NL	NEN 1010-7-702	SLO	SIST HD 384-7-702.S2
P	RSIUEE	TR	TS IEC 60364-7-702



Verifique que a alimentação eléctrica disponível e a frequência da rede correspondem à corrente de funcionamento requerida, tendo em conta a localização específica do equipamento, e a corrente necessária para alimentar qualquer outro aparelho ligado ao mesmo circuito.

ECLI15MA / ECLI20MA / ECLI30MA / ECLI40MA(*)
230V \surd +/- 10 % 50 Hz 1 Fase

Observe o esquema de cablagem correspondente em anexo.
A caixa de ligações encontra-se do lado direito da unidade. Três ligações destinam-se à alimentação eléctrica, e duas ao comando da bomba de filtração (Servocomando).

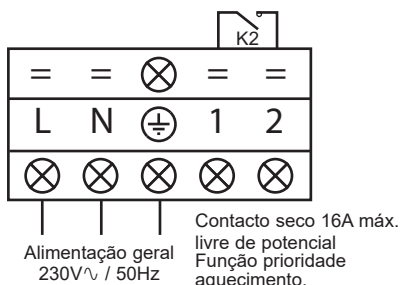

(*) Verificar as referências da máquina por meio da tabela de correspondências (ver etiqueta na capa do manual).

3. INSTALAÇÃO E LIGAÇÃO (continuação)



A linha de alimentação eléctrica deve ser dotada, de maneira apropriada, de um dispositivo de protecção fusível do tipo alimentação de motor (aM) ou disjuntor curvo D bem como de um disjuntor diferencial de 30mA (ver tabela anexa).

Modelos		ECLI15MA(*)	ECLI20MA(*)	ECLI30MA(*)	ECLI40MA(*)
Alimentação eléctrica	V/Ph/Hz	230V~ 50Hz	230V~ 50Hz	230V~ 50Hz	230V~ 50Hz
Calibre fusível tipo aM	A	8 aM	10 aM	16 aM	20 aM
Disjuntor curvo D	A	8 D	10 D	16 D	20 D
Secção de cabo	mm ²	3G 2,5	3G 2,5	3G 2,5	3G 4

(*) Verificar as referências da máquina por meio da tabela de correspondências (ver etiqueta na capa do manual).



Utilizar o cabo de alimentação do tipo RO 2V / R 2V ou equivalente.



As secções de cabo são fornecidas para um comprimento máximo de 25 m. Devem no entanto ser verificadas e adaptadas em função das condições de instalação.



Tenha sempre o cuidado de interromper a alimentação principal antes de abrir a caixa de comando eléctrico.

3.5 Primeira colocação em serviço

Procedimento de arranque - uma vez a instalação terminada, seguir e respeitar as etapas seguintes:

- 1) Faça girar os ventiladores com a mão a fim de verificar que ele pode girar livremente com a mão, e que a hélice está fixada correctamente sobre o eixo do motor.
- 2) Assegure-se que a unidade está correctamente ligada à alimentação principal (ver esquema de cablagem em anexo).
- 3) Active a bomba de filtração.
- 4) Verifique que todas as válvulas de água estão abertas, e que a água flui para a unidade antes de passar ao modo de aquecimento ou refrigeração.
- 5) Verifique que o tubo de purga de condensados está correctamente fixado e não apresenta nenhuma obstrução.
- 6) Active a alimentação eléctrica destinada à unidade, depois prima a tecla Marche/Arrêt (Marcha/Paragem)  no painel de comando.

3. INSTALAÇÃO E LIGAÇÃO (continuação)

- 7) Certifique-se de que os símbolos de alarme ou de bloqueio não são visualizados. Se for o caso, consultar o guia de resolução de problemas (consulte a secção 6.4).
- 8) Fixe o débito de água com a ajuda da válvula de by-pass (ver § 3.6 e 2.1), conforme previsto respectivamente para cada modelo, de modo a obter uma diferença de temperatura Entrada/Sáida de 2°C.
- 9) Após um funcionamento de alguns minutos, verifique que o ar que sai da unidade é refrigerado (entre 5 e 10°).
- 10) Com a unidade em serviço, desactive a bomba de filtração. A unidade deve parar automaticamente e apresentar o código de erro E03.
- 11) Faça funcionar a unidade e a bomba da piscina 24 horas sobre 24, até que seja atingida a temperatura da água pretendida. Quando a temperatura de entrada de água atingir o valor de afinação, a unidade pára. Volta então a arrancar automaticamente (desde que a bomba da piscina esteja em serviço) se a temperatura da piscina for inferior em pelo menos 0,5°C à temperatura regulada.

Controlador de débito - A unidade é dotada de um controlador de débito que activa a bomba de calor quando a bomba de filtração da piscina está em serviço, e desactiva-a quando a bomba de filtração está fora de serviço. Por falta de água, aparece no regulador o código de alarme E03 (Ver § 6.4).

Temporização - a unidade integra uma temporização de 3 minutos, a fim de proteger os componentes do circuito de comando, eliminar qualquer instabilidade em termos de re-arranque e qualquer interferência ao nível do contactor. Graças a esta temporização, a unidade voltar a arrancar automaticamente cerca de 3 minutos após qualquer corte do circuito de comando. Mesmo um corte de corrente de curta duração activa a temporização de arranque.

3. INSTALAÇÃO E LIGAÇÃO (continuação)

3.6 Ajuste do débito de água

Com as válvulas de entrada e saída de água abertas, ajustar a válvula de “by-pass” de modo a obter uma diferença de 2°C entre a temperatura de entrada e saída de água (ver esquema de princípio § 3.1). Pode verificar o Ajuste visualizando as temperaturas de entrada/saída directamente no painel de comando.



Nota: A abertura da válvula de “by-pass” provoca um débito menor, logo um aumento da ΔT .
O fecho da válvula de “by-pass” provoca um débito maior, logo uma diminuição da ΔT .

4. INTERFACE DO UTILIZADOR

4.1 Apresentação geral

A bomba de aquecimento está equipada com um painel de comando digital com ecrã táctil, ligado electricamente e pré-regulado de fábrica em modo de aquecimento.

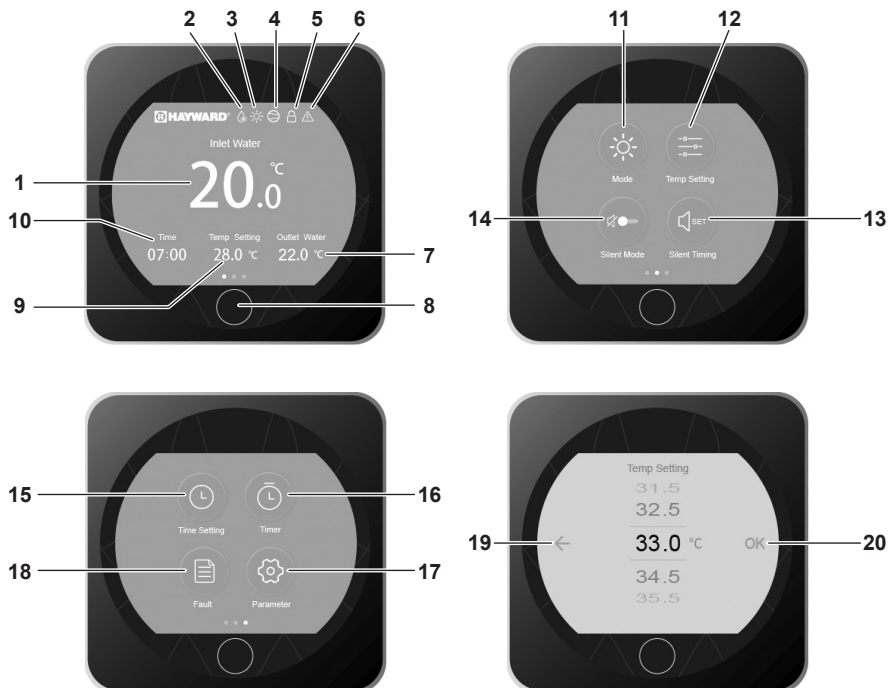

Legenda

1	Temperatura de entrada de água	11	Seleção do modo de funcionamento
2	Descongelamento em curso	12	Ajuste do ponto de instrução
3	Modo de funcionamento	13	Configurar temporizador do modo silêncio
4	Indicador luminoso de funcionamento do compressor	14	Ativação do modo silêncio
5	Bloqueio do ecrã	15	Ajuste data e hora
6	Alarme	16	Ajuste dos Temporizadores Funcionamento/Paragem
7	Saída de água	17	Acesso aos parâmetros avançados
8	Funcionamento/Paragem/Retorno	18	Acesso à lista de defeitos
9	Temperatura de instrução	19	Retorno (sem validação)
10	Hora	20	Validação

4. INTERFACE DO UTILIZADOR (continuação)

Modo OFF/PARAGEM

Quando a bomba de calor está parada (em modo de espera), a inscrição OFF aparece como indicado no ecrã.

O ecrã preto indica que a bomba de calor está parada, o ajuste dos parâmetros é possível neste modo.



Modo ON/FUNCIÓNAMENTO

Quando a bomba de calor está em funcionamento ou em regulação (a alcançar o ponto de instrução) o ecrã torna-se azul.



Para passar do modo OFF ao modo ON e inversamente, premir o botão .

4. INTERFACE DO UTILIZADOR (continuação)

4.2 Configuração de data e hora

O ajuste da data e da hora pode ser realizado indiferentemente em modo ON ou OFF.



- Premir 1 vezes o botão  para voltar ao ecrã principal.

4. INTERFACE DO UTILIZADOR (continuação)

4.3 Ajuste dos Temporizadores Funcionamento/Paragem

O ajuste desta função é necessária caso pretenda fazer funcionar a bomba de aquecimento por um período mais curto que o definido pelo relógio de filtração. Pode assim programar um arranque diferido e um arranque antecipado ou simplesmente impedir um intervalo horário de funcionamento (por exemplo a noite).

É possível programar um temporizador de Arranque e um temporizador de Paragem. O ciclo de configuração é «de hora a hora».



4. INTERFACE DO UTILIZADOR (continuação)



Azulado = Activado
Acinzentado = Desactivado

- Premir 2 vezes o botão  para voltar ao ecrã principal.

4. INTERFACE DO UTILIZADOR (continuação)

4.4 Ajuste do ponto de instrução

O ajuste do ponto de instrução realiza-se indiferentemente em modo ON ou em modo OFF com uma precisão de 0,5°C.



- Premir 1 vez o botão  para voltar ao ecrã principal.



É recomendável nunca ultrapassar a temperatura de 30°C para evitar a alteração das juntas.

4. INTERFACE DO UTILIZADOR (continuação)

4.5 Bloqueio e libertação do ecrã táctil

O bloqueio e o desbloqueio do ecrã pode ser efetuado indiferentemente em modo ON ou em modo OFF.



Bloqueio ativado



Bloqueio desativado

4. INTERFACE DO UTILIZADOR (continuação)

4.6 Ajustamento do modo SILÊNCIO

O modo silêncio permite utilizar a bomba de calor em modo económico e muito silencioso quando as necessidades de aquecimento são baixas (manter a temperatura da piscina ou assegurar o funcionamento ultra silencioso).

Esta função pode ser Activada/Desactivada manualmente ou usando um temporizador.

Ativação / Desativação



Modo silêncio desativado

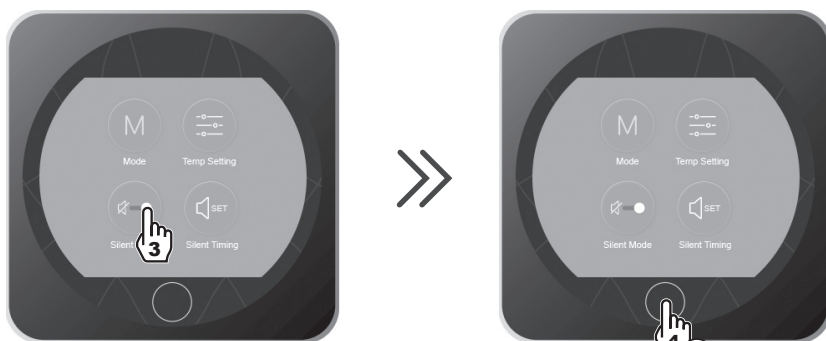

Modo silêncio activado

- Premir 1 vezes o botão  para voltar ao ecrã principal.

4. INTERFACE DO UTILIZADOR (continuação)

Ajuste do Temporizador do modo SILÊNCIO



4. INTERFACE DO UTILIZADOR (continuação)



- Premir 2 vezes o botão  para voltar ao ecrã principal.



O ciclo de configuração é «de hora a hora».
Depois de o activar, o temporizador fica activo 24 horas por dia.

5. MANUTENÇÃO E PREPARAÇÃO PARA O INVERNO

5.1 Manutenção

Estas operações de manutenção devem ser realizadas 1 vez por ano a fim de garantir a longevidade e o bom funcionamento da bomba de aquecimento.

- Limpar o evaporador com a ajuda de uma escova macia ou jacto de ar ou água (**Atenção, nunca utilizar um aspersor de alta pressão**).
- Verificar o bom escoamento dos condensados.
- Verificar o aperto das ligações hidráulicas e eléctricas
- Verificar a estanqueidade hidráulica do condensador.
- **Solicitar a um profissional** com formação que verifique a impermeabilidade do circuito frigorífico através do detetor de fugas.



Antes de qualquer operação de manutenção a bomba de aquecimento deve ser desligada de qualquer fonte de corrente eléctrica. As operações de manutenção devem ser realizadas unicamente por pessoal qualificado e habilitado para manipular fluidos de refrigeração.

5.2 Preparação para o Inverno

- Colocar a bomba de aquecimento em Modo “OFF”.
- Cortar a alimentação da bomba de aquecimento.
- Esvaziar o condensador com a ajuda do dreno para evitar qualquer risco de degradação. (risco importante de congelação).
- Fechar a válvula de “by-pass” e desapertar as uniões de entrada/saída.
- Expulsar ao máximo a água residual do condensador com a ajuda de uma pistola de ar.
- Obturar a entrada e a saída de água na bomba de aquecimento para evitar a entrada de corpos estranhos.
- Cobrir a bomba de aquecimento com a capa de Inverno prevista para este efeito.



Qualquer dano ocasionado por deficiente preparação para o Inverno implica a anulação da garantia.

6. ANEXOS

6.1 Esquemas eléctricos

ECLI15MA / ECLI20MA / ECLI30MA (*)

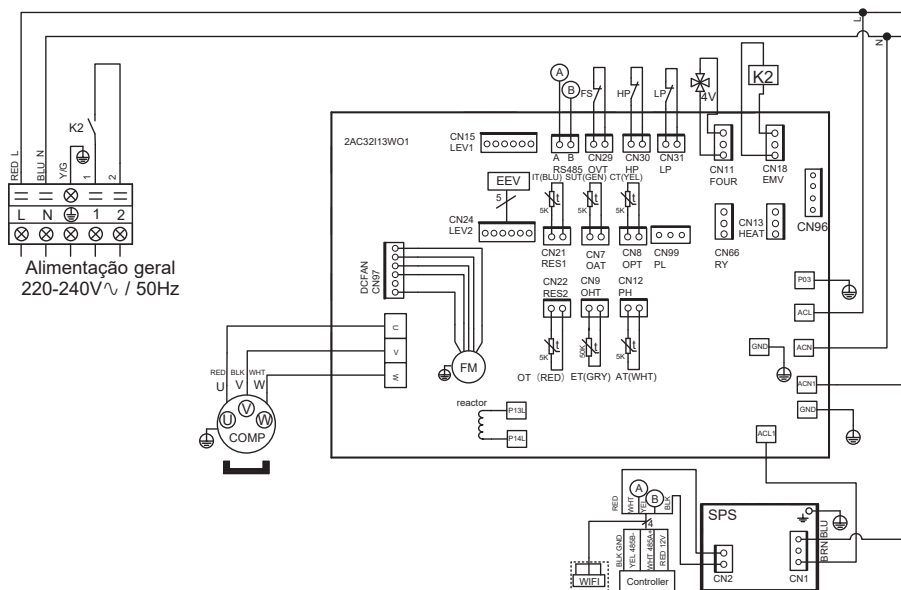

LEGENDA

- | | |
|--|--|
| AT : Sonda de temperatura do ar | LP : Pressóstato baixa pressão |
| COMP : Compressor | OT : Sonda de temperatura saída de água |
| CT : Sonda temperatura evaporador | SUT : Sonda de temperatura de aspiração |
| EEV : Regulador electrónico | 4V : Válvula de 4 vias |
| FM : Motor ventilador | K2 : Contacto seco livre de potencial 16A máx |
| FS : Detector presença de água | ET : Sonda de temperatura de descarga |
| HP : Pressóstato alta pressão | ----- : Opção |
| IT : Sonda de temperatura entrada de água | |

(*) Verificar as referências da máquina por meio da tabela de correspondências (ver etiqueta na capa do manual).

6. ANEXOS (continuação)

6.2 Ligações prioridade aquecimento bomba monofásica

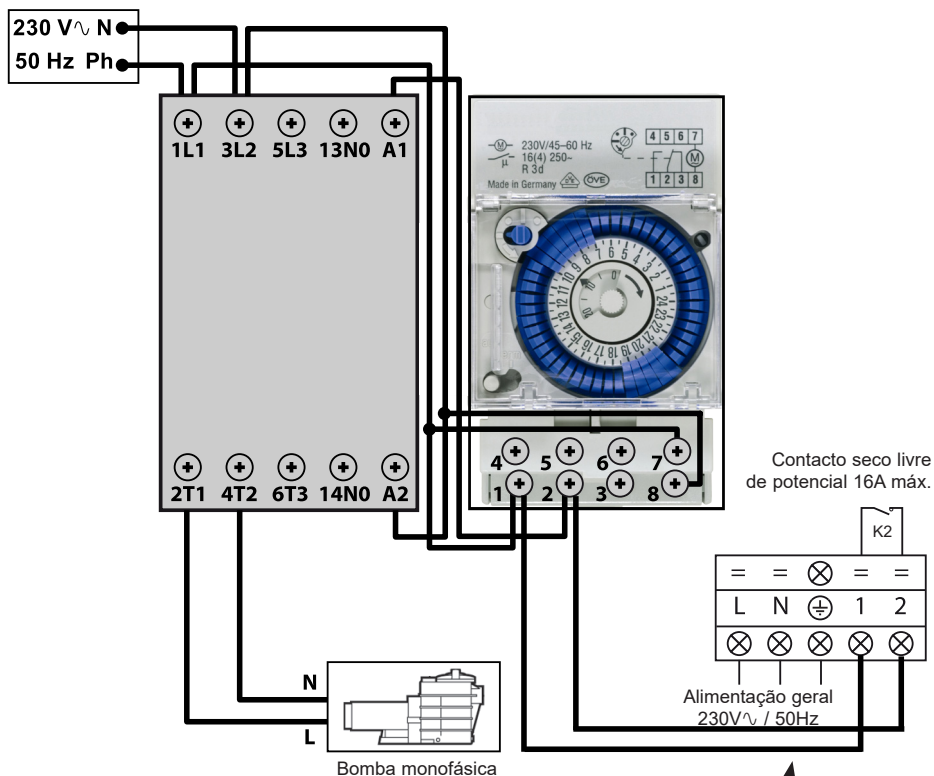

Os terminais 1 e 2 emitem um contacto seco livre de potencial, sem polaridade de 230 V \sim / 50 Hz.

Cablar os terminais 1 e 2 respeitando a cablagem indicada acima, a fim de controlar o funcionamento da bomba de filtração por ciclo de 2 minutos todas as horas se a temperatura da bacia for inferior ao ponto recomendado.

 Nunca conecte a alimentação da bomba de filtração directamente sobre os terminais 1 e 2.



Página deixada em branco intencionalmente

6. ANEXOS (continuação)

6.3 Vistas explodidas e peças sobressalentes / Addendum

ECLI15MA / 20MA / 30MA / 40MA (*)

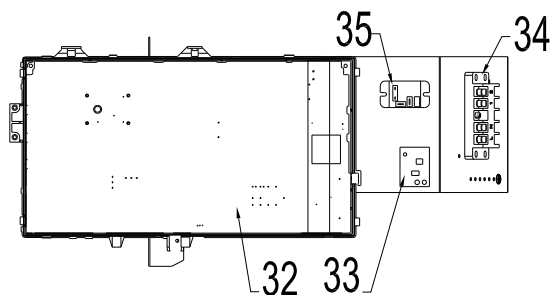
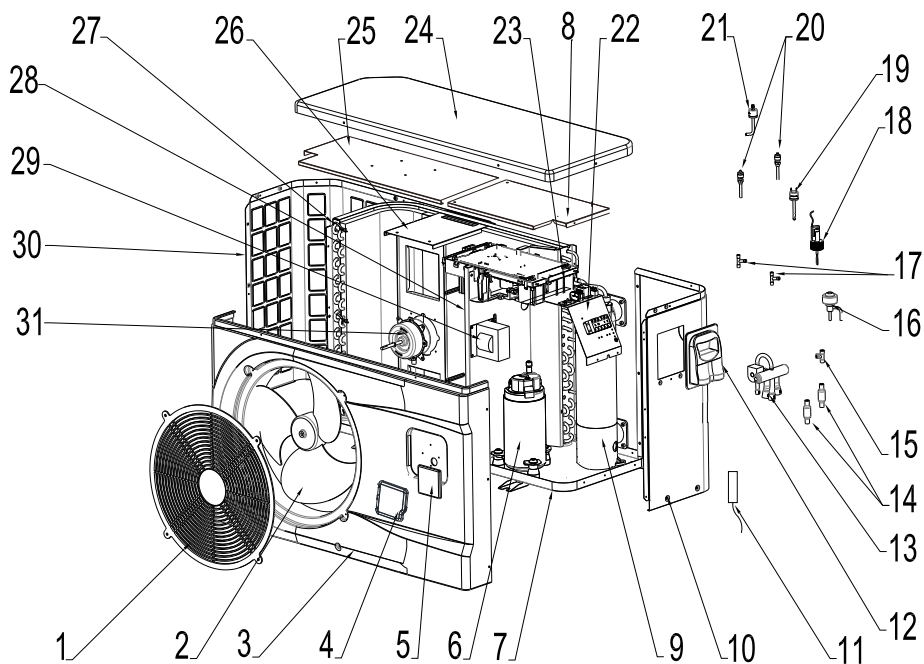

6. ANEXOS (continuação)

Rep	Designação	Ref.	ECLI15MA*	ECLI20MA*	ECLI30MA*	ECLI40MA*
1	Grelha de protecção do ventilador	HWX20000220245	✓	✓	✓	n/a
		HWX20000220369	n/a	n/a	n/a	✓
2	Hélice ventilador	HWX301030000006	✓	✓	✓	n/a
		HWX301030000001	n/a	n/a	n/a	✓
3	Painel ABS dianteiro	HWX809000099	✓	✓	✓	n/a
		HWX80900100	n/a	n/a	n/a	✓
4	Porta de protecção	HWX809000320	✓	✓	✓	✓
5	Regulador LED	HWX82300038	✓	✓	✓	✓
6	Compressor	HWX20000110448	✓	✓	✓	n/a
	Compressor	HWX80100003	n/a	n/a	n/a	✓
7	/	/	/	/	/	/
8	/	/	/	/	/	/
9	Condensador Titânio/PVC	HWX80600037	✓	n/a	n/a	n/a
		HWX32012120061	n/a	✓	n/a	n/a
		HWX32012120056	n/a	n/a	✓	n/a
		HWX80600096	n/a	n/a	n/a	✓
10	Painel direito	HWX80700445	✓	✓	✓	n/a
		HWX80700314	n/a	n/a	n/a	✓
11	Sonda de aspiração compressor 5k-560mm	HWX83000044	✓	✓	✓	n/a
	Sonda de aspiração compressor 5k-760mm	HWX83000053	n/a	n/a	n/a	✓
	Sonda temperatura de ar 5k-350mm	HWX83000049	✓	✓	✓	✓
	Sonda de saída de água 5k-410mm	HWX83000050	✓	✓	✓	✓
	Sonda de entrada de água 5k-850mm	HWX83000052	✓	✓	✓	✓
	Sonda de descarga compressor 50k-660mm	HWX83000026	✓	✓	✓	✓
	Sonda descongelação 5k-680mm	HWX83000051	✓	✓	✓	n/a
Sonda descongelação 5k-1040mm	HWX83000045	n/a	n/a	n/a	✓	
12	Alçapão de acesso eléctrico	HWX320922029	✓	✓	✓	✓
13	Válvula de 4 vias	HWX20041437	✓	✓	✓	✓
14	Filtro ø9.7-ø9.7 (Ø19)	HWX20000140178	✓	✓	✓	n/a
	Filtro ø9.7-ø9.7 (Ø28)	HWX20041444	n/a	n/a	n/a	✓
15	Conector T ø9.52-2 x ø6.35(T) x 1.0	HWX30403000002	✓	✓	✓	✓
16	Regulador electrónico	HWX20000140570	✓	✓	✓	n/a
		HWX81000013	n/a	n/a	n/a	✓
17	Conector T ø6.5-2 x ø6.5(T) x 0.75	HWX20001460	✓	✓	✓	✓
18	Detector de débito de água	HWX83000012	✓	✓	✓	✓
19	Pressóstato de baixa pressão NO 0.30MPa/0.15MPa	HWX20000360157	✓	✓	✓	✓
20	Medição da pressão 40 mm 1/2"	HWX20000140150	✓	✓	✓	✓
21	Pressóstato de alta pressão NC 3.2MPa/4.4MPa	HWX20013605	✓	✓	✓	✓
22	/	/	/	/	/	/
23	/	/	/	/	/	/
24	Painel superior	HWX809000055	✓	✓	✓	n/a
		HWX301090200806	n/a	n/a	n/a	✓
25	/	/	/	/	/	/
26	Suporte do motor	HWX80700218	✓	✓	✓	n/a
		HWX80700248	n/a	n/a	n/a	✓

(*) Verificar as referências da máquina por meio da tabela de correspondências (ver etiqueta na capa do manual).

6. ANEXOS (continuação)

ECLI15MA / 20MA / 30MA / 40MA (*)

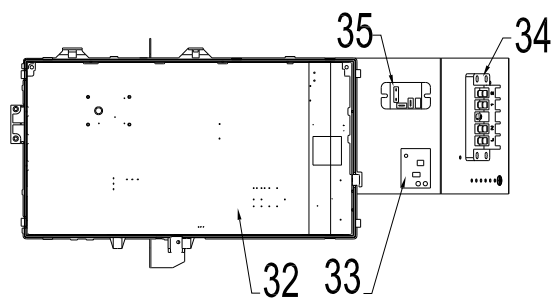
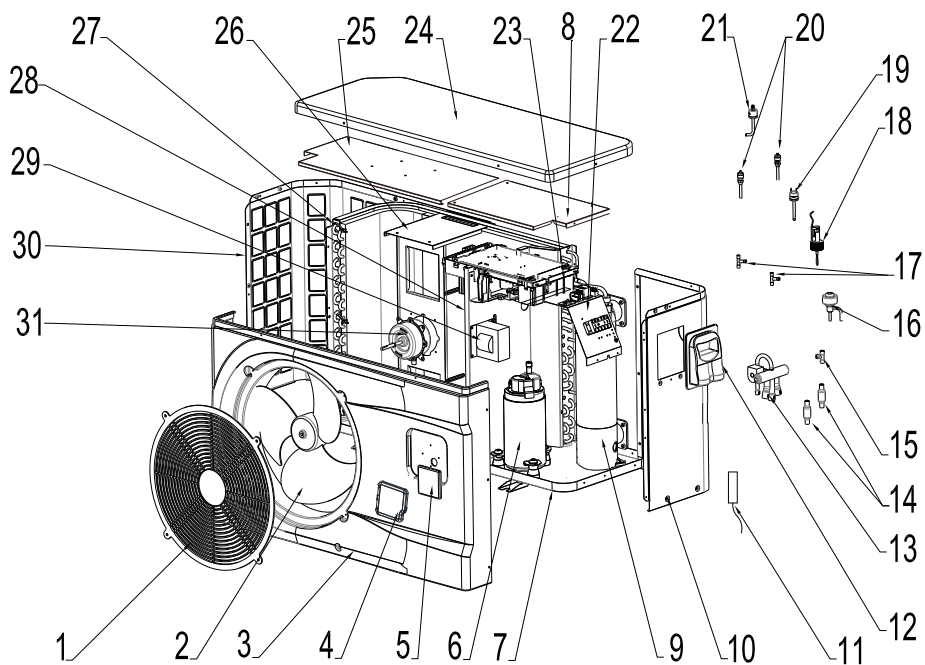

6. ANEXOS (continuação)

Rep	Designação	Ref.	ECLI15MA*	ECLI20MA*	ECLI30MA*	ECLI40MA*
27	Evaporador de alheta	HWX301060202502	✓	n/a	n/a	n/a
		HWX80600042	n/a	✓	n/a	n/a
		HWX80600043	n/a	n/a	✓	n/a
		HWX80600044	n/a	n/a	n/a	✓
28	/	/	/	/	/	
29	Bobina 16A 50Hz 5mH	HWX82500006	✓	✓	✓	n/a
	Bobina 20A 50Hz 5.2mH	HWX82500005	n/a	n/a	n/a	✓
30	Painel esquerdo	HWX80700446	✓	✓	✓	n/a
		HWX80700315	n/a	n/a	n/a	✓
31	Motor do ventilador DC	HWX80200018	✓	✓	✓	n/a
		HWX20000330132	n/a	n/a	n/a	✓
32	Placa eletrónica Driver	HWX82300052	✓	✓	✓	n/a
		HWX82300007	n/a	n/a	n/a	✓
33	Transformador 230V~/12DC	HWX82600008	✓	✓	✓	✓
34	Terminal L-N-GND -5 connexions 4mm ²	HWX40003901	✓	✓	✓	✓
35	Relés K2	HWX20000360297	✓	✓	✓	✓

(*) Verificar as referências da máquina por meio da tabela de correspondências (ver etiqueta na capa do manual).

6. ANEXOS (continuação)

6.4 Guia de resolução de avarias





Certas operações devem ser realizadas por um técnico habilitado.

Em caso de defeito da bomba de calor, o símbolo  aparece no ângulo superior esquerdo do ecrã.

Em caso de falha, as indicações seguintes aparecem no ecrã:



Após resolução do problema, o erro é reconhecido automaticamente, o triângulo desaparece.

- Para apagar a lista de erros, premir .
- Premir 2 vezes o botão  para voltar ao ecrã principal.

6. ANEXOS (continuação)

Avaria	Códigos de erro	Descrição	Solução
Avaria sonda de entrada de água	P01	O sensor está aberto ou apresenta curto-circuito.	Verificar os conetores CN21/RES1 na placa e o conetor de extensão ou substituir o sensor
Avaria sonda de saída de água	P02		Verificar os conetores N22/RES2 na placa e o conetor de extensão ou substituir o sensor
Avaria sonda temperatura exterior	P04		Verificar os conetores CN12/PH na placa e o conetor de extensão ou substituir o sensor
Avaria sonda descongelação	P05		Verificar os conetores CN8/OPT na placa e o conetor de extensão ou substituir o sensor
Defeito sonda de aspiração compressor	P07		Verificar os conetores CN7/OAT na placa e o conetor de extensão ou substituir o sensor
Defeito sonda de descarga compressor	P081		Verificar os conetores CN9/OHT na placa e o conetor de extensão ou substituir o sensor
Protecção de alta pressão	E01	O sensor está aberto ou apresenta curto-circuito.	Verificar os conetores CN30/HP no mapa ou substituir o sensor
			Verificar o caudal de água
			Verificar o detector de caudal de água
			Verificar a abertura das válvulas
			Verificar o by-pass
			Verificar a sujidade do evaporador
			Temperatura da água muito elevada
			Problema de gás não condensável após manutenção, fechar e retirar o vácuo do circuito frigorífico
		Carga de fluido muito elevada, retirar fluido com uma garrafa	
Protecção de baixa pressão	E02	O sensor está aberto ou apresenta curto-circuito.	Verificar a ligação AI/DI03 no mapa ou substituir o sensor
			Fuga grave de fluido de refrigeração, procurar uma fuga com o detector
			Fluxo de ar muito fraco, verificar a velocidade de rotação do ventilador
			Verificar a sujidade do evaporador, limpar a superfície
Avaria detector de débito	E03	O sensor está aberto ou apresenta curto-circuito.	Verificar a ligação AI/DI02 no mapa ou substituir o sensor
			Falta de água, verificar o funcionamento da bomba de filtração
			Verificar a abertura das válvulas de paragem
			Verificar a configuração do by-pass

6. ANEXOS (continuação)

Avaria	Códigos de erro	Descrição	Solução
Diferença de temperatura entrada/saída > 13 °C	E06	Aplicável apenas no modo Frio	Falta de água, verificar o funcionamento da bomba de filtração
			Verificar a abertura das válvulas de paragem
			Verificar a configuração do by-pass
Proteção Antigelo	E07	Temperatura de saída da água < 4 °C	Parar a bomba de calor, esvaziar o condensador, risco de congelamento
Problema de comunicação	E08	Não há nenhuma comunicação entre a placa eletrónica e a interface do utilizador	Verificar as ligações e os conetores - ver esquema elétrico
Proteção antigelo de nível 1	E19	2 °C < Temperatura da água < 4 °C e Temperatura do ar < 0 °C	Interromper o funcionamento da bomba de calor, esvaziar o condensador para evitar o congelamento. Por defeito, a bomba de calor inicia a bomba de filtração e a bomba de calor para evitar a entrada de gelo.
Proteção antigelo de nível 2	E29	Temperatura da água < 2 °C e Temperatura do ar < 0 °C	Interromper o funcionamento da bomba de calor, esvaziar o condensador para evitar o congelamento. Por defeito, a bomba de calor inicia a bomba de filtração e a bomba de calor para evitar a entrada de gelo.
Defeito do motor ventilador	F031	Motor bloqueado ou defeito de ligação	Verificar a sua livre rotação; verificar os conetores CN97/DCFan; substituir o motor
Defeito do motor ventilador	F051	Defeito de ligação	Verificar os conetores DCFAN/CN97; substituir o motor
Temperatura exterior demasiado baixa	TP	Limite de funcionamento atingido	Parar a bomba de calor

6. ANEXOS (continuação)

6.5 Garantia

CONDIÇÕES DE GARANTIA

Todos os produtos HAYWARD são garantidos contra todos os defeitos de fabrico ou de matéria-prima durante um período de dois anos a contar da data de aquisição. Qualquer reclamação de garantia deverá ser acompanhada de uma prova de compra contendo a data. Recomendamos, assim, que conserve a sua factura.

A garantia HAYWARD é limitada à reparação ou substituição, por opção da HAYWARD, dos produtos defeituosos desde que tenham sido submetidos a uma utilização normal, em conformidade com as prescrições mencionadas no respectivo manual de utilização, que o produto não tenha sido modificado de nenhuma forma e tenha sido utilizado unicamente com componentes e peças da HAYWARD. Os danos devidos ao gelo e aos ataques de agentes químicos não são garantidos. Todas as outras despesas (transporte, mão-de-obra...) estão excluídas da garantia.

A HAYWARD não poderá ser considerada responsável por qualquer dano directo ou indirecto proveniente da instalação, da ligação ou do funcionamento incorrecto do produto.

Para fazer aplicar uma garantia ou solicitar a reparação ou substituição de um artigo, dirija-se ao seu revendedor. Não será aceite qualquer devolução de material à nossa fábrica sem o nosso acordo prévio por escrito. As peças de desgaste não se encontram cobertas pela garantia.

Página deixada em branco intencionalmente

FULL INVERTER R32

HEIZPUMPENANLAGE FÜR EIN SCHWIMMBECKEN

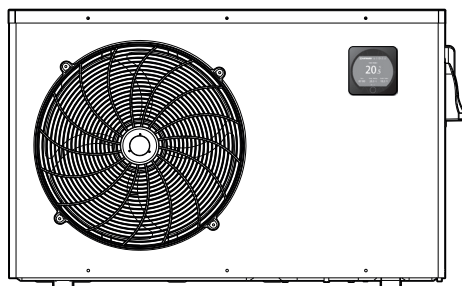

Einbau- & Anleitungshandbuch

INHALTSVERZEICHNIS

1. VORWORT	1
2. TECHNISCHE EIGENSCHAFTEN	4
2.1 Technische Daten der Wärmepumpe	4
2.2 Betriebsbereich	5
2.3 Maße	6
3. INSTALLATION UND ANSCHLUSS	7
3.1 Schematische Darstellung	7
3.2 Heizpumpenanlage	7
3.3 Hydraulischer Anschluss	8
3.4 Elektrischer Anschluss	9
3.5 Erste Inbetriebnahme	10
3.6 Einstellung des Wasserdurchsatzes	12
4. BENUTZEROBERFLÄCHE	13
4.1 Allgemeine Darstellung	13
4.2 Einstellung Datum und Uhrzeit	15
4.3 Einstellung der Schaltuhren AN/AUS	16
4.4 SollwertEinstellung	18
4.5 Sperren und Entsperren des Touchscreen	19
4.6 Aktivieren und Einstellen des SILENCE-Modus	20
5. WARTUNG UND WINTERZEIT	23
5.1 Wartung	23
5.2 Winterzeit	23
6. ANHANG	24
6.1 Stromtafel	24
6.2 Vorrangige Heizanschlüsse einphasige Pumpe	26
6.3 Explosionszeichnungen und Einzelteile / Addendum	28
6.4 Anleitung zur Fehlerbehebung	32
6.5 Garantie	35

Aufmerksam lesen und für einen späteren Gebrauch aufzubewahren.

Dieses Dokument ist dem Eigentümer des Schwimmbeckens zu übergeben und muss von diesem an einem sicheren Ort aufbewahrt werden.

1. VORWORT

Für den Erwerb dieser Hayward Schwimmbadwärmepumpe danken wir Ihnen. Die Hayward Wärmepumpe FULL INVERTER wurde gemäß strengen Fertigungsnormen konzipiert, um den geforderten Höchstqualitätsniveaus zu genügen.

Durch die Steuerlogik FULL INVERTER erreichte Anpassung von Leistung, Stromverbrauch und Geräuschpegel an den Heizbedarf Ihres Schwimmbades werden Ihnen die Hayward Wärmepumpen außergewöhnliche Leistungen während Ihrer gesamten Badesaison bieten.



Vor Benutzung des Geräts lesen Sie dieses Handbuch aufmerksam durch.

Die Hayward Wärmepumpen sind ausschließlich zum Heizen vom Schwimmbadwasser ausgelegt, verwenden Sie diese Geräte nicht für andere Zwecke.

Dieses Handbuch enthält alle benötigten Informationen hinsichtlich Installation, Behebung von Funktionsstörungen und Wartung.

Lesen Sie dieses Handbuch aufmerksam durch, bevor Sie das Gerät öffnen oder Wartungsarbeiten am Gerät durchführen. Der Produkthersteller haftet in keinem Fall für die Verletzung eines Benutzers oder die Beschädigung des Geräts, die aus Fehlern bei der Installation, der Pannenbehebung bzw. aus einer nicht erforderlichen Wartung ergeben. Die in diesem Handbuch enthaltenen Anweisungen müssen jederzeit unbedingt beachtet werden.

Jede nicht beachtetete Empfehlung führt zum Verlust der Garantie.

1. VORWORT (Fortsetzung)



Sicherheitsanweisungen



Dieses Gerät enthält R32.

Verwenden Sie niemals ein anderes Kältemittel als R32. Jeder andere gasförmiger Körper, der mit dem R32 gemischt wird, kann unnormal hohe Druckwerte verursachen, die eine Panne oder einen Rohrbruch und Personenverletzungen verursachen können.

Verwenden Sie bei Reparaturen oder Wartungsarbeiten niemals Kupferrohre mit einer Wandstärke von weniger als 0,8 mm.

Da die Wärmepumpe unter Druck steht, bohren Sie niemals die Rohrleitungen und versuchen Sie auch nicht diese zu löten. Es besteht Explosionsgefahr.

Setzen Sie niemals das Gerät Flammen, Funken oder anderen Entzündungsquellen aus. Das Gerät könnte explodieren und schwere oder sogar tödliche Verletzungen verursachen.

- Zur Lagerung muss die Wärmepumpe in einem gut belüfteten Raum mit einer größeren Bodenfläche als durch folgender Formel errechnete A_{\min} (m²) gelagert werden: $A_{\min} = (M / (2.5 \times 0.22759 \times h_0))^2$
M ist die Kältemittelfüllung im Gerät in und h₀ ist die Lagerungshöhe. Bei Lagerung auf dem Boden h₀ = 0,6 m.
- Die Wärmepumpe ist ausschließlich für eine Installation außerhalb von Gebäuden vorgesehen.
- Das Gerät muss durch qualifiziertes Personal installiert werden.
- Installieren Sie die Pumpe nicht auf einem Träger, der die Vibrationen des Geräts verstärken könnte.
- Prüfen Sie, dass der für das Gerät vorgesehene Träger für das Gerätgewicht korrekt dimensioniert ist.
- Installieren Sie die Pumpe nicht in einem Ort, der ihren Schallpegel verstärken könnte oder in einem Ort, in welchem das Gerätegeräusch die Nachbarschaft stören könnte.
- Alle elektrischen Anschlüsse müssen von einem qualifizierten Fachelektriker und gemäß den im Installationsland geltenden Normen ausgeführt werden – siehe § 3.4.
- Vor jeder Elektroarbeit trennen Sie die Hauptstromversorgung und schalten Sie den Trennschalter ab. Jede Versäumnis kann zum Stromschlag führen.

1. VORWORT (Fortsetzung)

- Prüfen Sie vor der Installation, dass das Erdkabel nicht geschnitten oder getrennt ist.
- Schließen und spannen Sie das Stromanschlusskabel korrekt an. Ein fehlerhafter Anschluss kann zur Beschädigung von Elektroteile führen.
- Falls die Wärmepumpe Wasser bzw. einer feuchten Umgebung ausgesetzt wird, kann daraus einen Stromschlag resultieren. Seien Sie sehr aufmerksam.
- Falls Sie irgendwelchen Fehler bzw. unnormale Situation entdecken, installieren Sie nicht die Wärmepumpe und setzen Sie sich sofort mit Ihrem Händler in Verbindung.
- Die Wartung und diversen Arbeiten müssen mit der in diesem Handbuch angegebenen Häufigkeit und zu den empfohlenen Zeitpunkten ausgeführt werden.
- Reparaturarbeiten müssen von qualifiziertem Personal ausgeführt werden.
- Verwenden Sie nur Originalersatzteile.
- Verwenden Sie niemals ein anderes als das in diesem Handbuch empfohlene Reinigungsverfahren.

Wichtige Informationen über das verwendete Kältemittel

Dieses Produkt enthält fluorierte Treibhausgase gemäß dem Kyoto-Protokoll. Setzen Sie diese Gase nicht in die Atmosphäre aus.

Kältemitteltyp: R32

GWP Wert (1): 675, Wert basiert auf dem 4. IPCC-Bericht.

Die auf Grundlage der Vorschrift F Gas 517/2014 Kältemittelmenge ist auf dem Typenschild des Geräts angegeben.

Gemäß europäischem oder lokalem Recht können regelmäßige Kältemittel-Lecktests erforderlich sein. Für weitere Informationen setzen Sie sich mit Ihrem Händler in Verbindung.

(1) Globaler Erwärmungsfaktor

2. TECHNISCHE EIGENSCHAFTEN

2.1 Technische Daten der Wärmepumpe

Modelle	CLASSIC FULL INVERTER	ECLI15MA(*)	ECLI20MA(*)	ECLI30MA(*)	ECLI40MA(*)
Versorgungsspannung	V	220V-240V ~ / 1ph / 50Hz			
Kältemittel	/	R32			
Ladung	kg	0,350	0,430	0,480	0,650
Gewicht in t CO ₂ -Äquivalent	/	0,24	0,29	0,32	0,44
Lecktest-Häufigkeit	/	Nicht vorgeschrieben aber jährlich empfohlen			
Wärmeleistung Min--Max ^(a)	kW	1,62--7,33	2,18--8,97	1,97 --11,66	2,85--17,06
Elektrische Leistungsaufnahme Min--Max ^(a)	kW	0,15--1,17	0,17--1,54	0,16--1,99	0,26--3,13
Nennstrom im Betrieb Min--Max ^(a)	A	1,15--5,32	1,27--6,91	1,08--8,96	1,41--13,69
COP Max--Min (a)	/	11,04--6,30	12,77--5,81	12,57--5,84	11,08--5,45
Wärmeleistung Min--Max ^(b)	kW	1,44--5,36	1,58--6,94	1,79--8,62	2,74--13,08
Elektrische Leistungsaufnahme Min--Max ^(b)	kW	0,24--1,14	0,27--1,53	0,290--1,90	0,428--2,97
COP Max--Min ^(b)	/	5,98--4,69	5,82--4,53	6,17--4,52	6,40--4,40
Maximaler Betriebsstrom (MBS)	A	6,4	8,4	10,9	16,6
Sicherungswert	aM	8	10	16	20
Schutzschalter Typ D	D	8	10	16	20
Anlaufstrom	A	< MBS			
Hydraulikanschluss	mm	50mm			
Nenn-Wasserdurchsatz (a)	m ³ /h	3,10	3,80	4,90	7,30
Max. wasserseitiger Druckverlust	kPa	2,3	2,9	6,4	6,7
Kompressor	/	DC Inverter Mitsubishi			DC Inverter Highly
Typ	/	Zweistufiger Schraubenkompressor			Zweistufiger Schraubenkompressor
Anzahl	/	1			
Wicklungswiderstand bei 20°C	Ohm	1,91			0,788
Gebläse	/	Axial			
Anzahl	/	1			
Durchmesser	mm	405			510
Schaufelanzahl	/	3			
Motor	/	DC Inverter			
Anzahl	/	1			
Drehzahl	U/Min.	600--700	600--800	850--950	600--850
Drehzahl im Ruhemodus	U/Min.	400	400	400	300
Schalldruckpegel in 1 m Abstand	dB(A)	35	43	43	46
Schalldruckpegel in 10 m Abstand	dB(A)	18	25	25	29
Nettoabmessungen des Geräts (L-B-H)	mm	1040 / 425 / 615			1130 / 460 / 780
Gewicht	kg	42	45	46	60

(*) Prüfen Sie die Maschinenreferenzen mit Hilfe der Vergleichstabelle (siehe Aufkleber auf dem Handbuchumschlag).



(a) Trockene Luft 27°C - Relative Feuchte 78% - Wassereinslasstemperatur 26°C.

(b) Trockene Luft 15°C - Relative Feuchte 71% - Wassereinslasstemperatur 26°C

2. TECHNISCHE EIGENSCHAFTEN (Fortsetzung)

2.2 Betriebsbereich

Benutzen Sie die Heizpumpenanlage innerhalb der folgenden Temperatur- und Luftfeuchtigkeitsbereichen, um ein sicheres und effizientes Funktionieren zu garantieren.

	Modus Erwärmen 	Modus Abkühlen 
Außentemperatur	-7°C – +35°C	+7°C – +43°C
Wassertemperatur	+12°C – +32°C	+8°C – +40°C
relative Luftfeuchtigkeit	< 80%	< 80%
Einstellbereich des Sollwerts	+15°C – +32°C	+8°C – +32°C



Wenn Temperatur oder Luftfeuchtigkeit nicht diesen Bedingungen entsprechen, können Sicherheitsmaßnahmen ausgelöst werden. Dann arbeitet die Heizpumpenanlage nicht mehr.



Die Höchsttemperatur für die Beheizung beträgt 32 °C, um eine Beschädigung der Verkleidung zu vermeiden. Hayward übernimmt keinerlei Verantwortung bei einer Verwendung über +32 °C.

2. TECHNISCHE EIGENSCHAFTEN (Fortsetzung)

2.3 Maße

Modelle:

ECLI15MA / ECLI20MA / ECLI30MA*

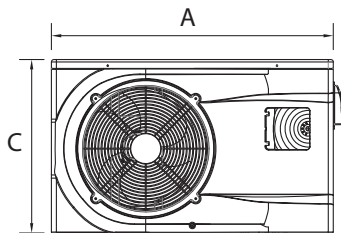
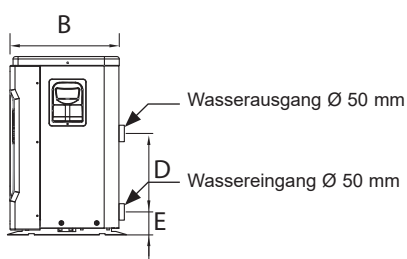

ECLI40MA*

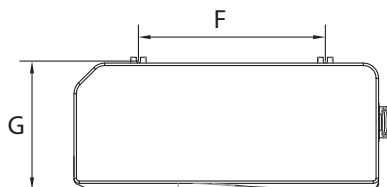
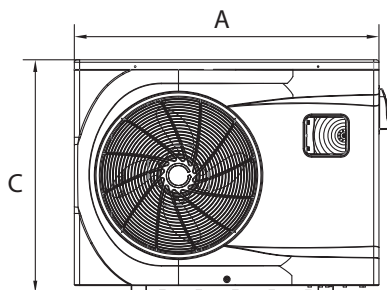
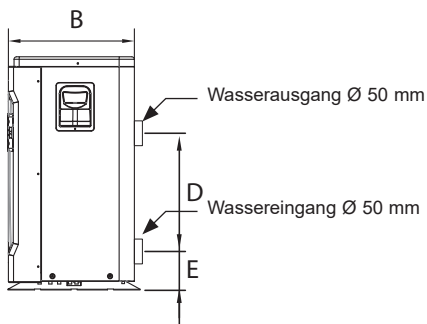

Einheit : mm

Markierung \ Modell(*)	ECLI15MA / ECLI20MA / ECLI30MA	ECLI40MA
A	956	1002
B	360	415
C	605	767
D	350	350
E	98	101
F	545	615
G	380	442

(*) Prüfen Sie die Maschinenreferenzen mit Hilfe der Vergleichstabelle (siehe Aufkleber auf dem Handbuchumschlag).

3. INSTALLATION UND ANSCHLUSS

3.1 Schematische Darstellung

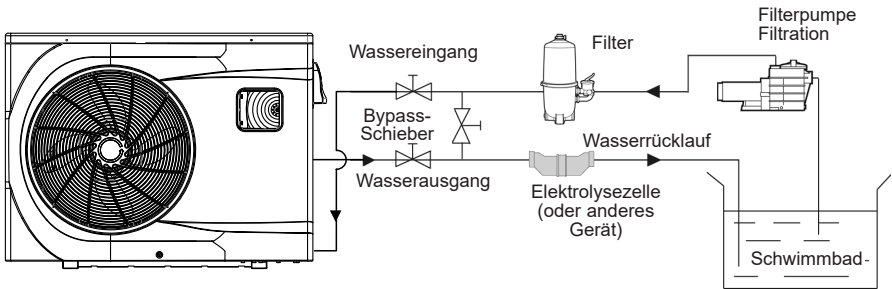

Anmerkung: Die Heizpumpenanlage verfügt über keinerlei Ausstattungs- oder Filtergerät. Die auf der Darstellung gezeigten Elemente werden vom Installateur bereitgestellt.

3.2 Heizpumpenanlage



Stellen Sie die Heizpumpenanlage im Außenraum und außerhalb vollständig geschlossener technischer Orte auf.

Geschützt aufgestellt muss der vorgeschriebene Mindestabstand wie unten genannt eingehalten werden, um die Gefahr einer Luftrückführung oder einer Minderung der effektiven Betriebsleistung der Heizpumpenanlage zu vermeiden.

Einheit : mm

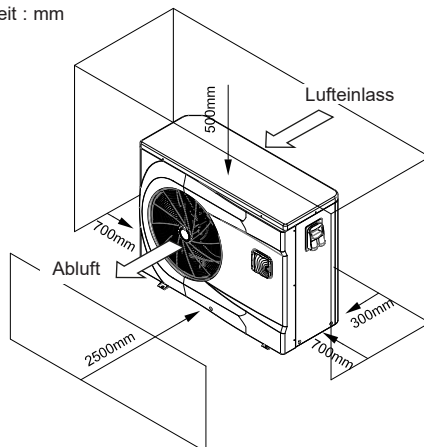

3. INSTALLATION UND ANSCHLÜSSE (Fortsetzung)



Installieren Sie vorzugsweise die Heizpumpenanlage auf einer separaten Betonbodenplatte oder auf einer festen Bestuhlung, die für diesen Zweck bestimmt ist und stellen Sie die Heizpumpenanlage auf die mitgelieferten Silentblöcke (Verschraubung und Unterlegscheiben nicht mitgeliefert).

Maximale Entfernung zwischen Heizpumpenanlage und Schwimmbecken 15 Meter.

Gesamtlänge (hin und zurück) der hydraulischen Leitungen 30 Meter.

Isolieren Sie sowohl die sichtbaren als auch die verdeckten hydraulischen Leitungen.

Die Wärmepumpe ist mit einem Mindestabstand vom Becken gemäß NF C 15-100 (d. h. für Frankreich 3,5 m entfernt von der Wasseroberfläche) oder gemäß den in den jeweiligen Ländern geltenden Installationsstandards zu installieren.

Die Wärmepumpe nicht in der Nähe einer Wärmequelle installieren.

Bei einer Installation in schneereichen Gebieten wird eine Abdeckung der Maschine empfohlen, um eine Schneeanhäufung auf dem Verdampfer zu verhindern.

3.3 Hydraulischer Anschluss

Die Heizpumpenanlage wird mit zwei Verbindungsstücken mit einem Durchmesser von 50 mm geliefert. Verwenden Sie PVC-Rohre mit 50 mm Durchmesser für das hydraulische Leitungsnetz. Schließen Sie die den Wassereingang der Heizpumpenanlage an die Leitung der Filtergruppe an. Schließen Sie dann den Wasserausgang der Heizpumpenanlage an die Wasserleitung des Beckens an (s. Darstellung weiter unten).

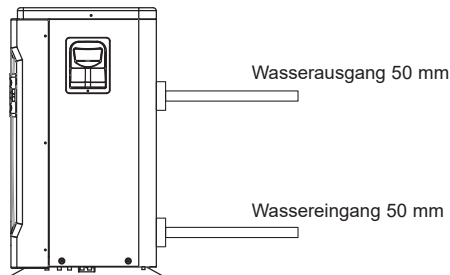

Installieren Sie einen Schieber, den so genannten "By-pass", zwischen den Eingang und den Ausgang der Heizpumpenanlage.



Wird ein automatischer Verteiler oder ein Elektrolyseur verwendet, muss dieser unbedingt nach der Heizpumpenanlage eingebaut werden, um so den Titan-Kondensator gegen eine zu hohe Konzentration chemischer Produkte zu schützen.



Achten Sie darauf, den By-pass-Schieber und die Verbindungsstücke am Ein- und Auslass der Anlage einzubauen, um den problemlosen Ablass der Anlage während der Wintermonate und einen einfacheren Zugang oder einen Abbau bei Wartungsarbeiten zu erleichtern.

3. INSTALLATION UND ANSCHLÜSSE (Fortsetzung)

3.4 Elektrischer Anschluss



Die Elektroinstallation und die Verkabelung dieses Gerätes müssen den geltenden Installationsvorschriften vor Ort entsprechen.

F	NF C15-100	GB	BS7671:1992
D	DIN VDE 0100-702	EW	EVHS-HD 384-7-702
A	ÖVE 8001-4-702	H	MSZ 2364-702/1994/MSZ 10-553 1/1990
E	UNE 20460-7-702 1993, RECBT ITC-BT-31 2002	M	MSA HD 384-7-702.S2
IRL	Wiring Rules (Richtlinien elektrischer Leitungen, Anm. d. Übers.) + IS HD 384-7-702	PL	PN-IEC 60364-7-702:1999
I	CEI 64-8/7	CZ	CSN 33 2000 7-702
LUX	384-7.702 S2	SK	STN 33 2000-7-702
NL	NEN 1010-7-702	SLO	SIST HD 384-7-702.S2
P	RSIUEE	TR	TS IEC 60364-7-702



Prüfen Sie, ob die verfügbare Stromversorgung und die Netzfrequenz den den erforderlichem Betriebsstrom entsprechen. Dabei müssen der jeweilige Standort des Gerätes und der erforderliche Strombedarf aller anderen, am gleichen Schaltkreis angeschlossener Geräte berücksichtigt werden.

ECLI15MA / ECLI20MA / ECLI30MA / ECLI40MA(*)
230V \surd +/- 10 % 50 Hz 1 Phase

Beachten Sie die schematische Darstellung der Verkabelung im Anhang. Die Anschlussbox befindet sich auf der rechten Seite der Anlage. Es gibt drei Anschlüsse für die Stromversorgung und zwei für die Steuerung der Filterpumpe (Nachlaufsteuerung).

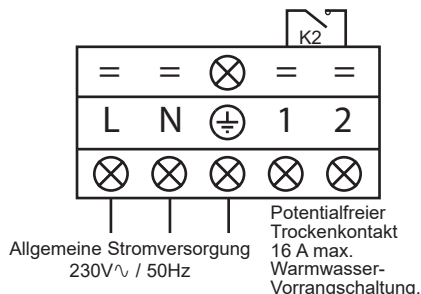

(*) Prüfen Sie die Maschinenreferenzen mit Hilfe der Vergleichstabelle (siehe Aufkleber auf dem Handbuchumschlag).

3. INSTALLATION UND ANSCHLUSS (Fortsetzung)



Die Leitung der Stromversorgung muss ordnungsgemäß mit einer Gerätesicherung vom Typ Motorversorgung (aM) oder einem Hauptschalter D sowie einem Differentialschalter 30mA ausgestattet sein (siehe nachfolgende Tafel).

Modelle		ECLI15MA(*)	ECLI20MA(*)	ECLI30MA(*)	ECLI40MA(*)
Netzteil	V/Ph/Hz	230V~ 50Hz	230V~ 50Hz	230V~ 50Hz	230V~ 50Hz
Sicherungsdurchmesser Typ aM	A	8 aM	10 aM	16 aM	20 aM
Leistungsschalter Kurve D	A	8 D	10 D	16 D	20 D
Leitungsquerschnitt	mm ²	3G 2,5	3G 2,5	3G 2,5	3G 4

(*) Prüfen Sie die Maschinenreferenzen mit Hilfe der Vergleichstabelle (siehe Aufkleber auf dem Handbuchumschlag).



Ein Netzkabel vom Typ RO 2V / R 2V oder vergleichbar.



Die Leitungsquerschnitte werden für maximal 25 m Länge angegeben. Sie müssen gleichwohl überprüft und auf die Installationsbedingungen angepasst werden.



Achten Sie stets darauf, dass die Hauptstromversorgung abgeschaltet ist, bevor Sie den elektrischen Steuerkasten öffnen.

3.5 Erste Inbetriebnahme

Verfahren zur Inbetriebnahme - Nachdem Sie die Installation beendet haben, gehen Sie wie folgt vor:

- 1) Drehen Sie die Ventilatoren von Hand, um zu überprüfen, dass sie sich frei von Hand bewegen lassen und dass der Propeller korrekt auf der Antriebswelle befestigt ist.
- 2) Vergewissern Sie sich, dass die Einheit korrekt an die Hauptstromversorgung angeschlossen ist (siehe Schaltplan im Anhang).
- 3) Starten Sie die Filterpumpe.
- 4) Vergewissern Sie sich, dass alle Wasserein- und auslässe offen sind und dass das Wasser in die Anlage, bevor es erwärmt oder abgekühlt wird.
- 5) Vergewissern Sie sich, dass das Ablassrohr für das Kondensat ordnungsgemäß befestigt und frei von Blockaden ist.
- 6) Aktivieren Sie die Stromversorgung für die Anlage und drücken Sie dann den Start/Stop-Knopf  auf der Bedientafel.

3. INSTALLATION UND ANSCHLUSS (Fortsetzung)

- 7) Prüfen Sie, dass die Alarm- bzw. Sperrsymbole nicht aufleuchten. Siehe gegebenenfalls die Anleitung zur Pannenbehebung (siehe § 6.4).
- 8) Arretieren Sie den Wasserdurchsatz mit dem By-pass-Schieber (s. § 3.6 und 2.1), wie für das jeweilige Modell vorgeschrieben, so dass eine Temperaturdifferenz zwischen Wasserein- und -ausgang von 2°C beibehalten wird.
- 9) Nachdem die Anlage einige Minuten in Betrieb ist, vergewissern Sie sich, dass die Luft, die aus der Anlage ausströmt, sich abgekühlt hat (um 5 bis 10°).
- 10) Ist die Anlage in Betrieb, schalten Sie die Filterpumpe ab. Die Anlage sollte sich automatisch abschalten und den Fehlercode E03 anzeigen.
- 11) Lassen sie die Anlage und die Schwimmbadpumpe 24 Stunden am Tag laufen, bis die gewünschte Wassertemperatur im Pool erreicht ist. Sobald das Eingangswasser die gewünschte Temperatur erreicht hat, schaltet sich die Anlage ab. Sie wird sich dann wieder automatisch einschalten (sofern die Schwimmbadpumpe in Betrieb ist), wenn die Temperatur des Schwimmbadwassers um mehr als 0,5°C von der eingestellten Temperatur abweicht.

Wasserdurchsatzregler - Die Anlage ist mit einem Regler für den Wasserdurchsatz ausgestattet, der diese einschaltet, wenn die Pumpe des Schwimmbadfilters in Betrieb ist und der diese ausschaltet, wenn die Filterpumpe außer Betrieb ist. Fehlt Wasser, so erscheint der Alarm-Code E03 auf dem Regler (siehe § 6.4).

Zeitliche Verzögerung - Die Anlage enthält eine zeitliche Verzögerung von 3 Minuten, welche die Komponenten des Steuerschaltkreises schützt und jegliche Instabilität bezüglich eines Neustarts sowie jegliche Störung im Bereich des Kontaktgebers verhindert. Aufgrund dieser zeitlichen Verzögerung startet die Anlage ca. 3 Minuten nach jeder Unterbrechung des Steuerschaltkreises automatisch neu. Selbst eine kurze Stromunterbrechung aktiviert diese zeitliche Verzögerung.

3. INSTALLATION UND ANSCHLUSS (Fortsetzung)

3.6 Einstellung des Wasserdurchsatzes

Stellen Sie den so genannten By-pass-Schieber bei geöffneten Wassereinlass- und -auslassschiebern so ein, dass ein Unterschied von 2°C zwischen der Wassereingangstemp. und der Wasserausgangstemp. erreicht wird (siehe Schematische Darstellung § 3.1). Sie können die Einstellung der Eingangs- und Ausgangstemperaturen direkt auf der Bedientafel kontrollieren.



Temperatur des Wassereinlasses

Temperatur des Wasserauslasses

Anmerkung: Das Öffnen des By-pass-Schiebers führt zu einem geringeren Durchsatz oder zu einer Zunahme des ΔT .
Das Schließen des By-pass-Schiebers führt zu einem höheren Durchsatz oder zu einer Verringerung des ΔT .

4. BENUTZEROBERFLÄCHE

4.1 Allgemeine Darstellung

Die Heizpumpenanlage ist mit einem digitalen Touchscreen-Bedienfeld ausgestattet, elektronisch angeschlossen und werksseitig auf Heizmodus voreingestellt.

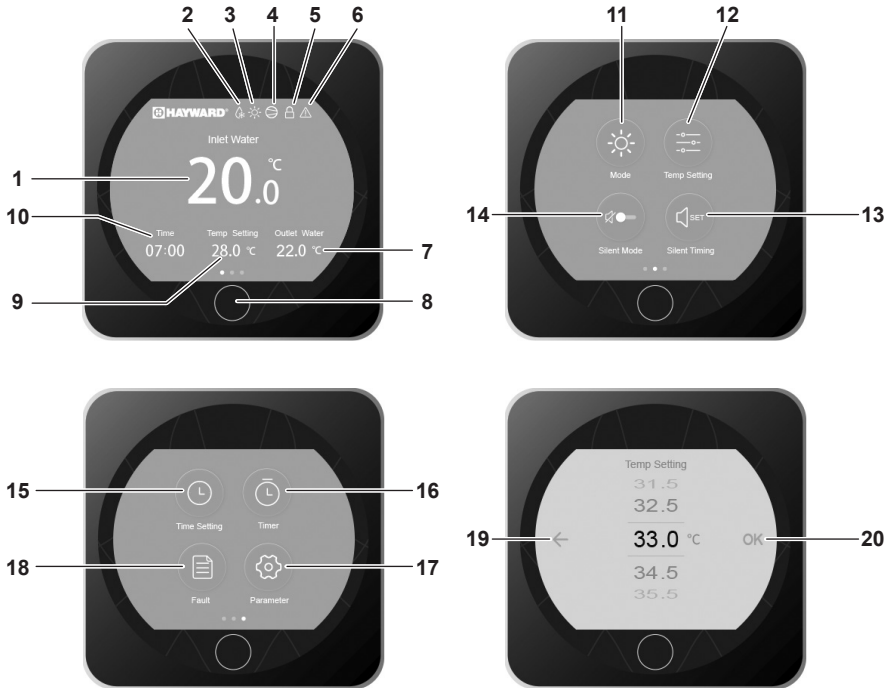

Zeichenerklärung

1	Temperatur Wassereingang
2	Abtauenmodus
3	Betriebsmodus
4	Betriebsanzeige des Kompressors
5	Bildschirm Sperre
6	Alarm
7	Wasserauslass
8	An/Aus/Zurück
9	Solltemperatur
10	Uhrzeit

11	Auswahl der Betriebsart
12	SollwertEinstellung
13	Einstellung Timer Ruhemodus
14	Aktivierung des Ruhemodus
15	Datum- und Uhrzeiteinstellung
16	Einstellung der An/Aus Schaltuhren
17	Zugriff erweiterte Parameter
18	Zugriff Fehlerliste
19	Zurück (ohne Bestätigung)
20	Bestätigung

4. BENUTZEROBERFLÄCHE (Fortsetzung)

Modus OFF/AUS

Wenn die Wärmepumpe still steht (Ruhemodus), wird OFF auf dem Bildschirm angezeigt. Ein schwarzer Bildschirm bedeutet, dass die Wärmepumpe still steht, in diesem Modus können die Parameter eingestellt werden.



Modus ON/AN

Wenn die Wärmepumpe läuft oder sich im Regelmodus befindet (Erreichen des Sollwerts), färbt sich der Bildschirm blau.





Um vom Modus OFF auf Modus ON und umgekehrt umzuschalten, drücken Sie auf den Knopf .

4. BENUTZEROBERFLÄCHE (Fortsetzung)

4.2 Einstellung Datum und Uhrzeit

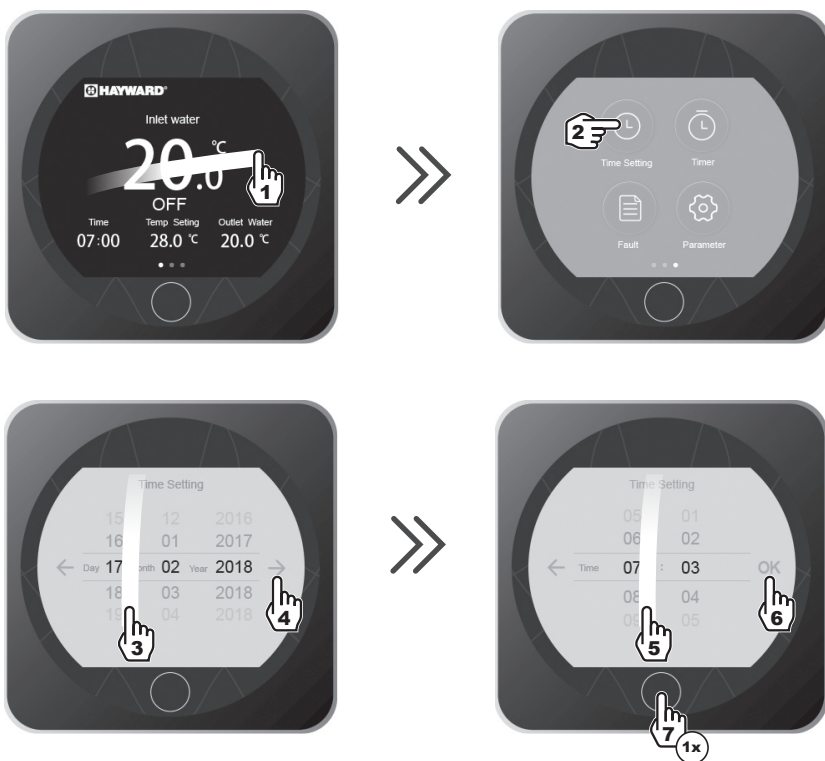
Die Datum- und Uhrzeiteinstellung kann beliebig im ON oder OFF Modus vorgenommen werden.



- Um zum Hauptbildschirm zurück zu kehren, drücken Sie 1 mal auf .

4. BENUTZEROBERFLÄCHE (Fortsetzung)

4.3 Einstellung der Schaltuhren AN/AUS

Die Einstellung dieser Funktion ist notwendig, wenn Sie die Heizpumpenanlage über einen kürzeren als den von der Filteruhr vorgegebenen Zeitraum betreiben möchten. Damit können Sie einen zeitlich versetzten Beginn oder ein vorzeitiges Ende programmieren bzw. einen Teilbereich des Betriebszeitplans unterbinden (zum Beispiel nachts).

Sie können Ein Start-Schaltuhren und Ein Stopp-Schaltuhren programmieren. Die Einstellung erfolgt in Schritten von jeweils einer Stunde.



4. BENUTZEROBERFLÄCHE (Fortsetzung)



Blaue Hinterlegung = Aktiviert
Graue Hinterlegung = Deaktiviert

- Um zum Hauptbildschirm zurück zu kehren, drücken Sie 2 mal auf .

4. BENUTZEROBERFLÄCHE (Fortsetzung)

4.4 Sollwerteinstellung

Die Einstellung des Sollwerts kann mit einer Genauigkeit von 0,5°C beliebig im Modus ON oder im Modus OFF vorgenommen werden.



- Um zum Hauptbildschirm zurück zu kehren, drücken Sie 1 mal auf .



Es wird empfohlen, niemals eine Temperatur von 30°C zu überschreiten, um Veränderungen der Auskleidungen zu vermeiden.

4. BENUTZEROBERFLÄCHE (Fortsetzung)

4.5 Sperren und Entsperren des Touchscreen

Die Sperre und Freigabe des Bildschirms kann beliebig im Modus ON oder im Modus OFF vorgenommen werden.



Sperre aktiviert



Sperre deaktiviert

4. BENUTZEROBERFLÄCHE (Fortsetzung)

4.6 Aktivieren und Einstellen des SILENCE-Modus

Der Ruhemodus ermöglicht eine äußerst leise Nutzung der Wärmepumpe Energiesparmodus, da der Heizbedarf gering ist (Aufrechterhaltung der Beckentemperatur oder falls extrem leiser Betrieb erforderlich).

Diese Funktion kann entweder manuell oder über eine Zeitschaltung Aktiviert/ Deaktiviert werden.

Aktivierung/Deaktivierung



Ruhemodus deaktiviert



Ruhemodus aktiviert



- Um zum Hauptbildschirm zurück zu kehren, drücken Sie 1 mal auf .

4. BENUTZEROBERFLÄCHE (Fortsetzung)

Einstellung der Schaltuhr der RUHE-Modus



4. BENUTZEROBERFLÄCHE (Fortsetzung)



- Um zum Hauptbildschirm zurück zu kehren, drücken Sie 2 mal auf .



Die Einstellung erfolgt in Schritten von jeweils einer Stunde. Sobald der Timer aktiviert ist, ist er 7 Tage in der Woche aktiv.

5. WARTUNG UND WINTERZEIT

5.1 Wartung

Diese Maßregeln zur Wartung müssen ein Mal pro Jahr durchgeführt werden, um die Langlebigkeit und gute Funktionsweise der Heizpumpenanlage zu garantieren.

- Reinigen Sie den Evaporator mit Hilfe einer flexiblen Bürste, einem Luft- oder einem Wasserstrahl (**Achtung: Verwenden Sie niemals einen Hochdruckreiniger**).
- Kontrollieren Sie den korrekten Abfluss des Kondensats.
- Kontrollieren Sie die hydraulischen und elektrischen Anschlüsse.
- Kontrollieren Sie die hydraulische Dichtigkeit des Kondensator.
- Die Dichtheit des Kältekreislaufs mithilfe eines Leckdetektors **durch eine autorisierte Fachkraft** prüfen lassen.



Vor allen Wartungsmaßnahmen muss die Heizpumpenanlage von jeglicher Stromversorgung getrennt werden. Die Wartungsmaßnahmen müssen von einem qualifizierten Fachmann durchgeführt werden, dem der Umgang mit Kühlfüssigkeiten vertraut ist.

5.2 Winterzeit

- Stellen Sie die Heizpumpenanlage auf den Modus "OFF".
- Trennen Sie die Heizpumpenanlage von der Stromversorgung.
- Leeren Sie den Kondensator mit Hilfe des Wasserablassers, um jegliche Schadensgefahr zu vermeiden. (großes Frostrisiko).
- Schließen Sie den By-pass-Schieber und lösen Sie die Eingangs- und Ausgangsverbindungsstücke.
- Entfernen Sie so gut es geht das Altwasser im Kondensator mit Hilfe einer Druckluftpistole.
- Verschließen Sie den Wasserein- und -ausgang an der Heizpumpenanlage, um das Eindringen von Fremdkörpern zu verhindern.
- Decken Sie die Heizpumpenanlage mit der für diesen Zweck vorgesehenen Winterschutzhülle ab.



Jeglicher Schaden, der durch eine schlechte Winterlagerung entsteht, hebt alle Garantieansprüche auf.

6. ANHANG

6.1 Stromtafel

ECLI15MA / ECLI20MA / ECLI30MA (*)

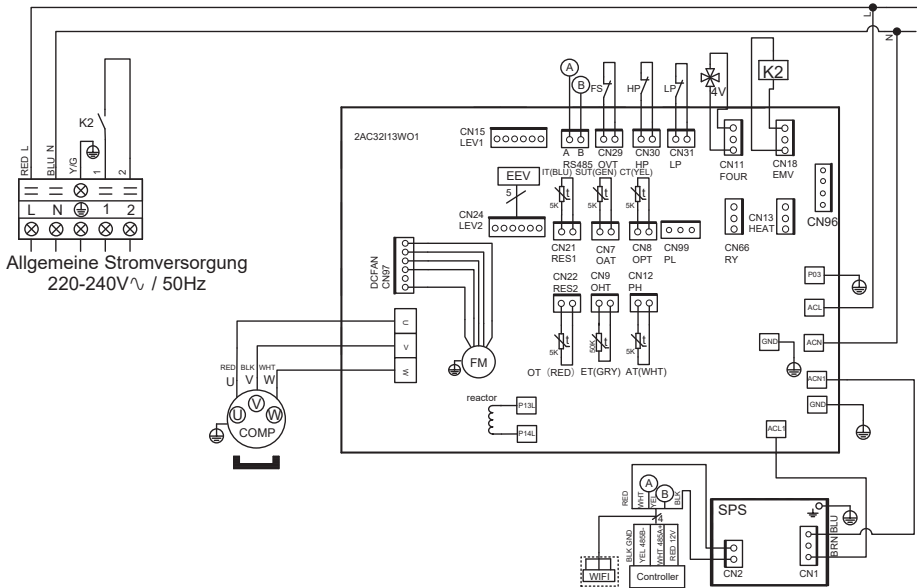

LEGENDE

- | | |
|---|---|
| AT : AUSSENTEMPERSURENSOR | LP : NIEDRIGDRUCKREGLER |
| COMP : KOMPRESSOR | OT : SENSOR DER TEMPERATUR DES WASSERAUSLASSES |
| CT : TEMPERATURSENSOR DES EVAPORATORS | SUT : SENSOR DER SAUGTEMPERATUR |
| EEV : ELEKTRONISCHER SENSOR | 4V : 4-WEGE-VENTIL |
| FM : GEBLÄSEMOTOR | K2 : POTENTIALFREIER TROCKENKONTAKT MAX. 16 A |
| FS : SENSOR DES WASSERSTANDES | ET : DRUCKTEMPERATURSONDE |
| HP : HOCHDRUCKREGLER | OPTION : OPTION |
| IT : SENSOR DER TEMPERATUR DES WASSEREINLASSES | |

(*) Prüfen Sie die Maschinenreferenzen mit Hilfe der Vergleichstabelle (siehe Aufkleber auf dem Handbuchsanschlag).

6. ANHANG (Fortsetzung)

ECLI40MA (*)

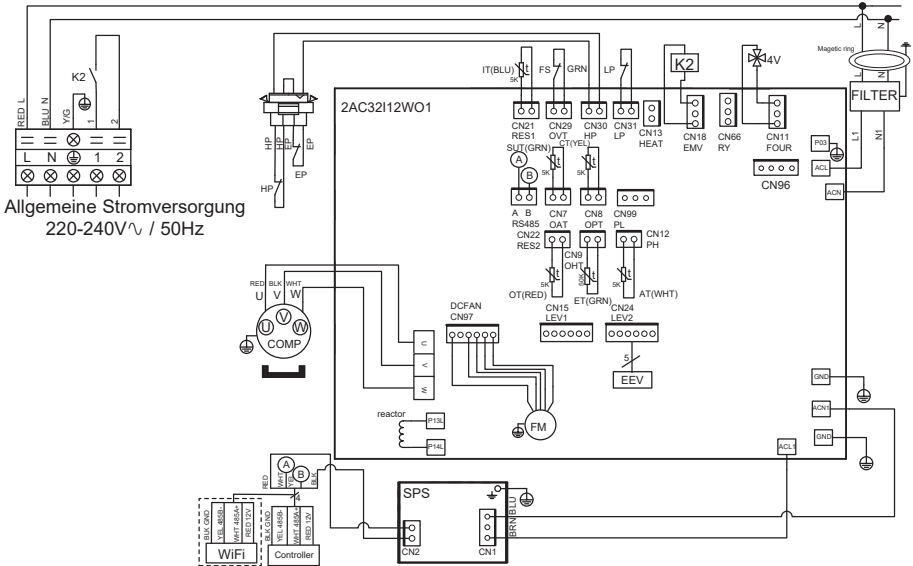

LEGENDE

- | | |
|---|---|
| AT : AUSSENTEMPATURSENSOR | LP : NIEDRIGDRUCKREGLER |
| COMP : KOMPRESSOR | OT : SENSOR DER TEMPERATUR DES WASSERAUSLASSES |
| CT : TEMPERATURSENSOR DES EVAPORATORS | SUT : SENSOR DER SAUGTEMPERATUR |
| EEV : ELEKTRONISCHER SENSOR | 4V : 4-WEGE-VENTIL |
| FM : GEBLÄSEMOTOR | K2 : POTENTIALFREIER TROCKENKONTAKT MAX. 16 A |
| FS : SENSOR DES WASSERSTANDES | ET : DRUCKTEMPERATURSONDE |
| HP : HOCHDRUCKREGLER | OPTION : OPTION |
| IT : SENSOR DER TEMPERATUR DES WASSEREINLASSES | |

(*) Prüfen Sie die Maschinenreferenzen mit Hilfe der Vergleichstabelle (siehe Aufkleber auf dem Handbuchsanschlag).

6. ANHANG (Fortsetzung)

6.2 Vorrangige Heizanschlüsse einphasige Pumpe

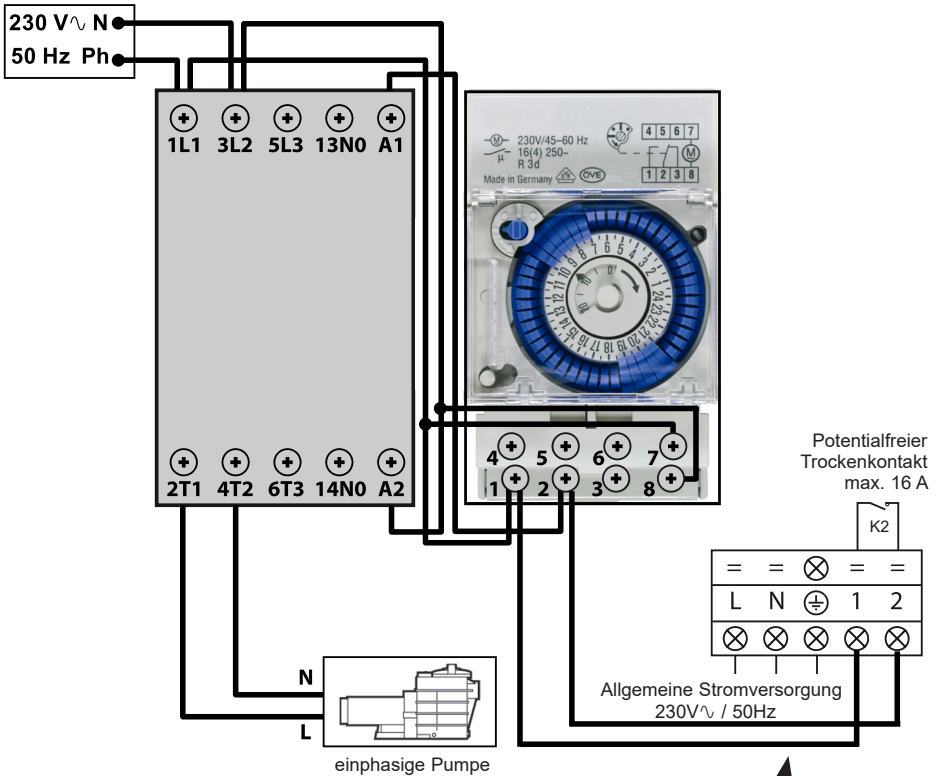

Die Anschlüsse 1 und 2 liefern einen potenzialfreien Trockenkontakt ohne Polarität 230 V \sim / 50 Hz. Verkabeln Sie die Anschlüsse 1 und 2 unter Berücksichtigung des folgenden Kabelschemas, um die Filtrationspumpe jede Stunde in einem 2-Minuten-Zyklus zu aktivieren, wenn die Temperatur des Beckens unter den Sollwert fällt.

! Die Stromversorgung der Filtrationspumpe niemals direkt an die Anschlüsse 1 und 2 anschließen.



Seite bewusst leer gelassen

6. ANHANG (Fortsetzung)

6.3 Explosionszeichnungen und Einzelteile / Addendum

ECLI15MA / 20MA / 30MA / 40MA (*)

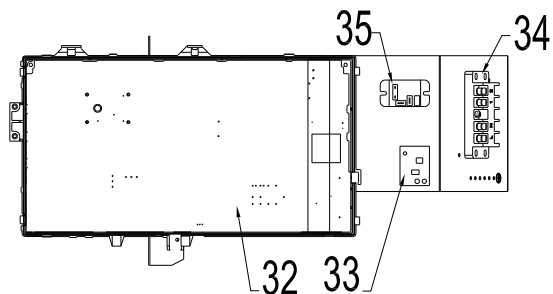
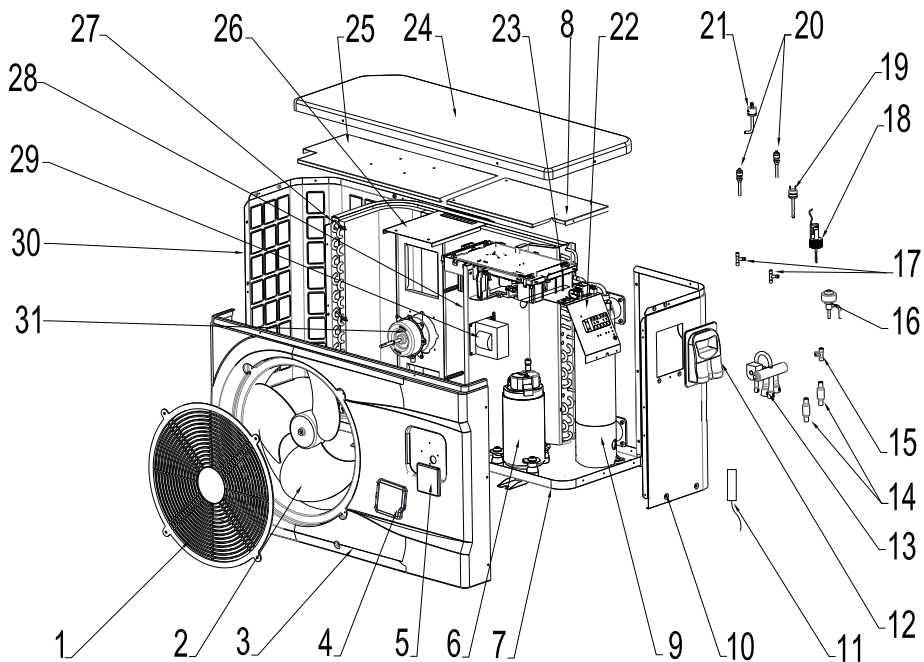

6. ANHANG (Fortsetzung)

Nr	Beschreibung	Ref.	ECLI15MA*	ECLI20MA*	ECLI30MA*	ECLI40MA*
1	Schutzgitter des Gebläses	HWX20000220245	✓	✓	✓	n/a
		HWX20000220369	n/a	n/a	n/a	✓
2	Gebläsepropeller	HWX301030000006	✓	✓	✓	n/a
		HWX301030000001	n/a	n/a	n/a	✓
3	Schild Vorne	HWX809000099	✓	✓	✓	n/a
		HWX809001100	n/a	n/a	n/a	✓
4	Schutztür	HWX809000320	✓	✓	✓	✓
5	LED-Regler	HWX82300038	✓	✓	✓	✓
6	Kompressor	HWX20000110448	✓	✓	✓	n/a
	Kompressor	HWX80100003	n/a	n/a	n/a	✓
7	/	/	/	/	/	/
8	/	/	/	/	/	/
9	Titan/PVC--Kondensator	HWX80600037	✓	n/a	n/a	n/a
		HWX32012120061	n/a	✓	n/a	n/a
		HWX32012120056	n/a	n/a	✓	n/a
		HWX806000096	n/a	n/a	n/a	✓
10	Rechtes Schild	HWX80700445	✓	✓	✓	n/a
		HWX80700314	n/a	n/a	n/a	✓
11	Saugsonde des Kompressors 5k-560mm	HWX83000044	✓	✓	✓	n/a
	Saugsonde des Kompressors 5k-760mm	HWX83000053	n/a	n/a	n/a	✓
	Lufttemperatursensor 5k-350mm	HWX83000049	✓	✓	✓	✓
	Sensor des Wasserauslasses 5k-410mm	HWX83000050	✓	✓	✓	✓
	Sensor des Wassereinlasses 5k-850mm	HWX83000052	✓	✓	✓	✓
	Abgabekompressorsensor 50k-660mm	HWX83000026	✓	✓	✓	✓
	Abtausonde 5k-680mm	HWX83000051	n/a	✓	✓	n/a
Abtausonde 5k-1040mm	HWX83000045	n/a	n/a	n/a	✓	
12	Stromanschlussklappe	HWX320922029	✓	✓	✓	✓
13	4-Wege-Ventil	HWX20041437	✓	✓	✓	✓
14	Filter ø9.7-ø9.7 (Ø19)	HWX20000140178	✓	✓	✓	n/a
	Filter ø9.7-ø9.7 (Ø28)	HWX20041444	n/a	n/a	n/a	✓
15	T-Stecker ø9.52-2 x ø6.35(T) x 1.0	HWX30403000002	✓	✓	✓	✓
		HWX20000140570	✓	✓	✓	n/a
16	Elektronischer Sensor	HWX81000013	n/a	n/a	n/a	✓
17	T-Stecker ø6.5-2 x ø6.5(T) x 0.75	HWX20001460	✓	✓	✓	✓
18	Sensor des Wasserdurchsatzes	HWX83000012	✓	✓	✓	✓
19	Druckregler Niederdruck NO 0.30MPa/0.15MPa	HWX20000360157	✓	✓	✓	✓
20	Druckanschluss 40mm-1/2"	HWX20000140150	✓	✓	✓	✓
21	Druckregler Hochdruck NC 3.2MPa/4.4MPa	HWX20013605	✓	✓	✓	✓
22	/	/	/	/	/	/
23	/	/	/	/	/	/
24	Obere Platte	HWX80900055	✓	✓	✓	n/a
		HWX301090200806	n/a	n/a	n/a	✓
25	/	/	/	/	/	/
26	Motorträger	HWX80700218	✓	✓	✓	n/a
		HWX80700248	n/a	n/a	n/a	✓

6. ANHANG (Fortsetzung)

ECLI15MA / 20MA / 30MA / 40MA (*)

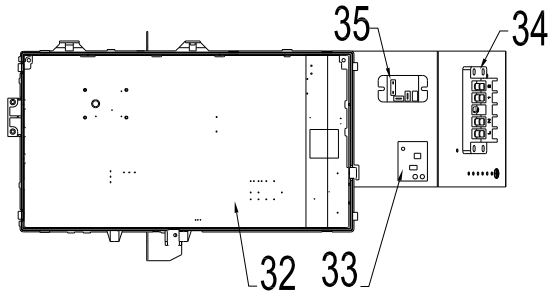
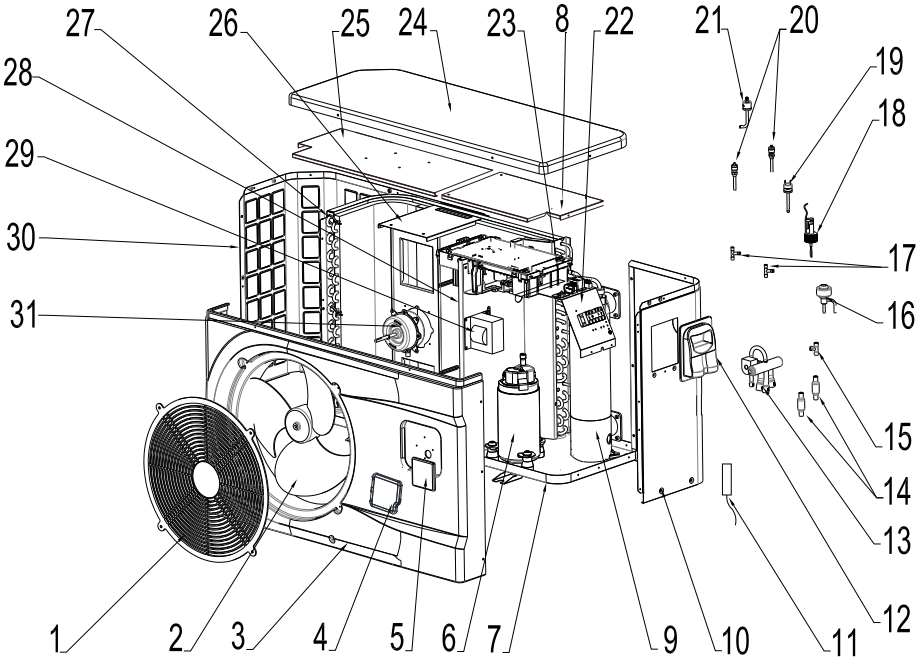

6. ANHANG (Fortsetzung)

Nr	Beschreibung	Ref.	ECLI15MA*	ECLI20MA*	ECLI30MA*	ECLI40MA*
27	Flügelevaporator	HWX301060202502	✓	n/a	n/a	n/a
		HWX80600042	n/a	✓	n/a	n/a
		HWX80600043	n/a	n/a	✓	n/a
		HWX80600044	n/a	n/a	n/a	✓
28	/	/	/	/	/	
29	Wicklung 16A 50Hz 5mH	HWX82500006	✓	✓	✓	n/a
	Wicklung 20A 50Hz 5.2mH	HWX82500005	n/a	n/a	n/a	✓
30	Linkes Schild	HWX80700446	✓	✓	✓	n/a
		HWX80700315	n/a	n/a	n/a	✓
31	Motor Ventilator DC	HWX80200018	✓	✓	✓	n/a
		HWX20000330132	n/a	n/a	n/a	✓
32	Elektronische Treiberkarte	HWX82300052	✓	✓	✓	n/a
		HWX82300007	n/a	n/a	n/a	✓
33	Transformator 230V~/12DC	HWX82600008	✓	✓	✓	✓
34	Klemmleiste L-N-GND -5 Anschlüssen 4mm ²	HWX40003901	✓	✓	✓	✓
35	Relais K2	HWX20000360297	✓	✓	✓	✓

(*) Prüfen Sie die Maschinenreferenzen mit Hilfe der Vergleichstabelle (siehe Aufkleber auf dem Handbuchumschlag).

6. ANHANG (Fortsetzung)

6.4 Anleitung zur Fehlerbehebung





Manche Maßnahmen müssen von einem mit der Anlage vertrauten Techniker durchgeführt werden.

Bei einem Fehler an der Wärmepumpe wird das Symbol  im oberen linken Ecke des Bildschirms angezeigt.

Im Falle einer Störung erscheinen die folgenden Anzeigen auf dem Bildschirm:



Nach Behebung des Problems wird der Fehler automatisch quittiert, das Dreieck wird ausgeblendet.

- Um die Fehlerliste zu löschen, auf  .
- Um zum Hauptbildschirm zurück zu kehren, drücken Sie 2 mal auf .

6. ANHANG (Fortsetzung)

Störung	Fehlercode	Beschreibung	Lösung
Ausfall des Sensors des Wassereinlasses	P01	Der Sensor ist offen oder kurzgeschlossen	Prüfen Sie die Verbindung CN21/RES1 auf der Karte und den Verlängerungsstecker oder tauschen Sie den Sensor aus.
Ausfall des Sensors des Wasserauslasses	P02		Prüfen Sie die Verbindung N22/RES2 auf der Karte und den Verlängerungsstecker oder tauschen Sie den Sensor aus.
Ausfall des Außentempersensors	P04		Prüfen Sie die Verbindung CN12/PH auf der Karte und den Verlängerungsstecker oder tauschen Sie den Sensor aus.
Ausfall des Magnetspulensensors	P05		Prüfen Sie die Verbindung CN8/OPT auf der Karte und den Verlängerungsstecker oder tauschen Sie den Sensor aus.
Fehler an der Saugsonde des Kompressors	P07		Prüfen Sie die Verbindung CN7/OAT auf der Karte und den Verlängerungsstecker oder tauschen Sie den Sensor aus.
Fehler Fördermengenfühler des Kompressors	P081		Prüfen Sie die Verbindung CN9/OHT auf der Karte und den Verlängerungsstecker oder tauschen Sie den Sensor aus.
Hochdruckregler	E01	Der Sensor ist offen oder kurzgeschlossen	Prüfen Sie die Verbindung CN30/HP an der Karte prüfen oder Sensor ersetzen.
			Wasserdurchfluss prüfen
			Wasserdurchflussmesser prüfen
			Öffnung der Ventile prüfen
			Druckausgleicher prüfen
			Verschmutzung des Verdampfers prüfen
			Wassertemperatur zu warm
			Problem von nicht kondensierbarem Material nach einer Wartung, Kältekreislaufs leeren und evakuieren.
Zu hohe Kältemittelfüllung, Flüssigkeit in eine Flasche ableiten.			
Niedrigdruckregler	E02	Der Sensor ist offen oder kurzgeschlossen	Den Anschluss AI/DI03 an der Karte prüfen oder Sensor ersetzen.
			Großes Kältemittelleck, Leck mit Detektor suchen
			Zu geringer Luftstrom, Drehzahl des Ventilators prüfen
			Verschmutzung des Verdampfers prüfen, dessen Oberfläche reinigen
Ausfall des Durchsatzsensors	E03	Der Sensor ist offen oder kurzgeschlossen	Den Anschluss AI/DI02 an der Karte prüfen oder Sensor ersetzen.
			Fehlendes Wasser, Funktion der Filterpumpe prüfen
			Öffnung der Absperrventile prüfen
			Einstellung des Druckausgleichers prüfen

6. ANHANG (Fortsetzung)

Störung	Fehlercode	Beschreibung	Lösung
Differenz Temperatur Eingang/ Ausgang > 13 °C	E06	Nur im Modus Kalt anwendbar	Fehlendes Wasser, Funktion der Filterpumpe prüfen
			Öffnung der Absperrventile prüfen
			Einstellung des Druckausgleichers prüfen
Frostschutz Frostmodus	E07	Temperatur Wasserausgang < 4 °C	Wärmepumpe stoppen, Kondensator leeren, Frostgefahr
Kommunikationsproblem	E08	Keine Kommunikation zwischen der elektronischen Karte und der Benutzeroberfläche	Prüfen Sie die Anschlüsse und die Verbindung – siehe Schaltschema
Frostschutz der Stufe 1	E19	2° < Wassertemperatur < 4° und Lufttemperatur < 0°	Den Betrieb der Wärmepumpe anhalten, den Kondensator leeren, um Frostbildung zu verhindern; standardmäßig startet die Wärmepumpe die Filterpumpe, um Frostbildung zu verhindern
Frostschutz der Stufe 2	E29	Wassertemperatur < 2° und Lufttemperatur < 0°	Den Betrieb der Wärmepumpe anhalten, den Kondensator leeren, um Frostbildung zu verhindern; standardmäßig startet die Wärmepumpe die Filterpumpe, um Frostbildung zu verhindern
Fehler des Gebläsemotors	F031	Blockierter Motor oder Anschlussfehler	Prüfen Sie die freie Drehung; prüfen Sie die Verbindung CN97/DCFan; tauschen Sie den Motor aus
Fehler des Gebläsemotors	F051	Anschlussfehler	Prüfen Sie die Verbindung DCFAN/CN97; tauschen Sie den Motor aus
Außentemperatur zu niedrig	TP	Betriebsgrenze erreicht	Schalten Sie die Wärmepumpe aus

6. ANHANG (Fortsetzung)

6.5 Garantie

GARANTIEVORAUSSETZUNGEN

Für sämtliche HAYWARD-Produkte bestehen innerhalb von zwei Jahren ab Kauf des Produkts Garantien hinsichtlich sämtlicher Fertigungsfehler oder Materialmängel. Bei jedem Antrag auf Garantie muss der Nachweis des Kaufs, einschließlich des Belegs zum Kaufdatum, erbracht werden. Wir bitten Sie also um Aufbewahrung Ihrer Rechnung.

Die HAYWARD-Garantie, die grundsätzlich ganz im Ermessen von HAYWARD liegt, beschränkt sich auf die Reparatur oder den Ersatz, hinsichtlich fehlerhafter Produkte, sofern sie sachgemäß benutzt wurden, nämlich in Übereinstimmung mit den im Benutzerleitfaden befindlichen Vorschriften; das Produkt darf keinesfalls verändert worden sein und darf ausschließlich mit den Bauteilen und Einzelteilen von HAYWARD benutzt werden. Die Garantie erstreckt sich nicht auf Beschädigungen aufgrund von Frost und Einwirkungen chemischer Substanzen.

Ausgeschlossen von der Garantie sind sämtliche sonstigen Kosten (Transport, Arbeitstätigkeit...). HAYWARD kann nicht haftbar gemacht werden für direkte oder indirekte Schäden, die sich aufgrund falscher Montage, fehlerhaften Anschlusses oder der falschen Funktion des Produkts ergeben.

Falls Sie einen Garantieantrag stellen, eine Reparatur beantragen oder ein Produkt austauschen möchten, so wenden Sie sich bitte an Ihren Händler. Ausgeschlossen ist eine Material-Rücksendung an unser Werk ist ohne unsere vorherige schriftliche Zustimmung.

Die Verschleißteile unterliegen nicht der Garantie.

Seite bewusst leer gelassen

FULL INVERTER R32

ZWEMBAD WARMTEPOMP

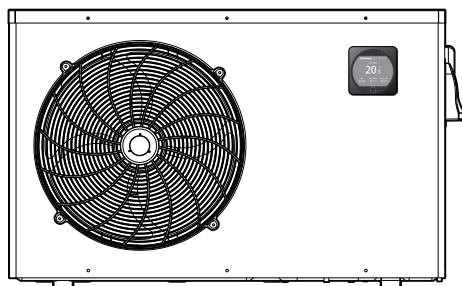

Installatie- en bedieningshandleiding

INHOUD

1. VOORWOORD	1
<hr/>	
2. TECHNISCHE EIGENSCHAPPEN	4
2.1 Technische gegevens over de warmtepomp	4
2.2 Werkgebied	5
2.3 Afmetingen	6
<hr/>	
3. INSTALLATIE EN AANSLUITING	7
3.1 Basisschema	7
3.2 Warmtepomp	7
3.3 Hydraulische aansluiting	8
3.4 Elektrische aansluiting	9
3.5 Eerste gebruik	10
3.6 Instelling van het waterdebiet	12
<hr/>	
4. GEBRUIKERSINTERFACE	13
4.1 Algemene voorstelling	13
4.2 Instelling Datum en Tijd	15
4.3 De timers aan/uit instellen	16
4.4 Instelwaarde aanpassen	18
4.5 Het touchscreen vergrendelen en ontgrendelen.	19
4.6 Instellen van de SILENCE functie	20
<hr/>	
5. ONDERHOUD EN OVERWINTERING	23
5.1 Onderhoud	23
5.2 Overwintering	23
<hr/>	
6. BIJLAGEN	24
6.1 Elektrische schema's	24
6.2 Aansluitingen prioriteit verwarming eenfasepomp	26
6.3 Opengewerkte tekeningen en onderdelen / Addendum	28
6.4 Gids voor het probleemoplossing	32
6.5 Garantie	35

Aandachtig lezen en bewaren voor later gebruik.

Dit document moet aan de eigenaar van het zwebad overhandigd en door hem op een veilige plaats bewaard worden.

1. VOORWOORD

Hartelijk dank voor de aanschaf van deze Hayward zwembadwarmtepomp. De Hayward FULL INVERTER warmtepomp is ontworpen volgens strenge productienormen om te voldoen aan de hoogste kwaliteitseisen.

De Hayward warmtepompen bieden u uitzonderlijke prestaties terwijl gedurende het hele zwemseizoen door het vermogen, het elektriciteitsverbruik en het geluidsniveau aan te passen aan de verwarming van uw zwembad dankzij de FULL INVERTER-besturingslogica.



Lees de instructies in deze handleiding zorgvuldig door voordat u het apparaat in gebruik neemt.

Hayward warmtepompen zijn uitsluitend bedoeld voor het verwarmen van zwembadwater, gebruik deze apparatuur niet voor andere doeleinden.

Deze handleiding bevat alle noodzakelijke informatie over installatie, probleemoplossing en onderhoud.

Lees deze handleiding zorgvuldig door voordat u het apparaat opent of onderhoudswerkzaamheden aan het apparaat uitvoert. De fabrikant van dit product is in geen geval aansprakelijk voor enig letsel van een gebruiker of schade aan het apparaat als gevolg van mogelijke fouten tijdens de installatie, het verhelpen van storingen of onnodig onderhoud. Het is van essentieel belang om de instructies in deze handleiding te allen tijde op te volgen.

Elke aanbeveling die niet wordt opgevolgd, maakt de garantie ongeldig.

VOORWOORD (vervolg)



Veiligheidsinstructies



Dit apparaat bevat R32.

Gebruik nooit een ander koelmiddel dan R32. Elk ander gasvormig lichaam vermengd met de R32 kan abnormaal hoge drukken veroorzaken die kunnen leiden tot breuken in leidingen en/of persoonlijk letsel.

Gebruik bij reparaties of onderhoudswerkzaamheden nooit koperen buizen met een dikte van minder dan 0,8 mm.

Omdat de warmtepomp onder druk staat, mag u nooit gaten boren in de leidingen of proberen deze te solderen. Er bestaat explosiegevaar.

Stel het apparaat nooit bloot aan vlammen, vonken of andere ontstekingsbronnen. Het kan ontploffen en ernstige of zelfs dodelijke verwondingen veroorzaken.

- In geval van opslag moet de warmtepomp worden opgeslagen in een goed geventileerde ruimte met een vloeroppervlakte van meer dan A_{\min} (m²) volgens de volgende formule: $A_{\min} = (M / (2,5 \times 0,22759 \times h_0))^2$
M is de koelmiddelvulling in het apparaat in kg en h₀ is de opslaghoogte. Voor grondopslag h₀ = 0,6 m.
- De warmtepomp is uitsluitend bestemd voor installatie buiten gebouwen.
- Het apparaat moet door gekwalificeerd personeel worden geïnstalleerd.
- Installeer de warmtepomp niet op een steun die de trillingen van het apparaat kan versterken.
- Controleer of de bijgeleverde beugel voor het apparaat de juiste maat heeft voor het gewicht van het apparaat.
- Installeer de warmtepomp niet op een plaats waar het geluidsniveau kan worden versterkt of op een plaats waar het geluid van het apparaat de buurt kan verstoren.
- Alle elektrische aansluitingen moeten worden uitgevoerd door een gekwalificeerde elektromonteur en in overeenstemming met de geldende normen in het land van installatie, zie § 3.4.
- Schakel de hoofdstroomtoevoer en de hoofdschakelaar uit voordat u elektrische werkzaamheden uitvoert. Elke nalatigheid kan elektrische schokken veroorzaken.
- Controleer voor de installatie of de aardkabel niet is doorgeknipt of losgekoppeld.

VOORWOORD (vervolg)

- Sluit de voedingskabel goed aan en draai deze goed vast. Als de aansluiting niet correct is, kunnen elektrische onderdelen beschadigd raken.
- Blootstelling van de warmtepomp aan water of een vochtige omgeving kan elektrocutie veroorzaken. Wees voorzichtig.
- Als u een defect of een abnormale situatie constateert, stop dan de installatie van de warmtepomp en neem onmiddellijk contact op met uw dealer.
- Onderhoud en diverse bewerkingen moeten worden uitgevoerd met de aanbevolen frequentie en tijden, zoals aangegeven in deze handleiding.
- Reparaties moeten worden uitgevoerd door gekwalificeerd personeel.
- Gebruik alleen originele reserveonderdelen.
- Gebruik nooit een andere reinigingsprocedure dan die welke in deze handleiding wordt aanbevolen.

Belangrijke informatie over het gebruikte koelmiddel

Dit product bevat gefluoreerde broeikasgassen die onder het Kyoto-protocol vallen. Laat deze gassen niet in de atmosfeer vrijkomen.

Type koelmiddel R32

GWP-waarde(1): 675, Waarde gebaseerd op het 4e IPCC-rapport.

De hoeveelheid koudemiddel op basis van de F Gas 517/2014 regeling staat aangegeven op het typeplaatje van het apparaat.

Afhankelijk van de Europese of lokale wetgeving kunnen periodieke koelmiddellekkage-inspecties vereist zijn. Neem contact op met uw lokale distributeur voor meer informatie.

(1) Aardopwarmingsvermogen

2. TECHNISCHE EIGENSCHAPPEN

2.1 Technische gegevens over de warmtepomp

Modellen	CLASSIC FULL INVERTER	ECLI15MA(*)	ECLI20MA(*)	ECLI30MA(*)	ECLI40MA(*)
Voedingsspanning	V	220V-240V ~ / 1ph / 50Hz			
Koelmiddel	/	R32			
Belasting	kg	0,350	0,430	0,480	0,650
Massa in TCO ₂	/	0,24	0,29	0,32	0,44
Frequentie van de controle op lekkage	/	Geen eisen, maar jaarlijks geadviseerd			
Verwarmingscapaciteit Min--Max ^(a)	kW	1,62--7,33	2,18--8,97	1,97 --11,66	2,85--17,06
Opgenomen elektrisch vermogen Min--Max ^(a)	kW	0,15--1,17	0,17--1,54	0,16--1,99	0,26--3,13
Nominale bedrijfstrom Min--Max ^(a)	A	1,15--5,32	1,27--6,91	1,08--8,96	1,41--13,69
COP Max--Min (a)	/	11,04--6,30	12,77--5,81	12,57--5,84	11,08--5,45
Verwarmingscapaciteit Min--Max ^(b)	kW	1,44--5,36	1,58--6,94	1,79--8,62	2,74--13,08
Opgenomen elektrisch vermogen Min--Max ^(b)	kW	0,24--1,14	0,27--1,53	0,290--1,90	0,428--2,97
COP Max--Min ^(b)	/	5,98--4,69	5,82--4,53	6,17--4,52	6,40--4,40
Maximale bedrijfstrom (MBS)	A	6,4	8,4	10,9	16,6
Vermogen van de zekering	A/m	8	10	16	20
D-curve stroomonderbreker	D	8	10	16	20
Startstroom	A	< MBS			
Hydraulische aansluiting	mm	50mm			
Nominaal waterdebiet (a)	m ³ /h	3,10	3,80	4,90	7,30
Max. waterdrukverlies	kPa	2,3	2,9	6,4	6,7
Compressor	/	DC-omvormer Mitsubishi			DC-omvormer Hoogst
Type	/	Dubbele roterende			Dubbele roterende
Hoeveelheid	/	1			
Wikkelweerstand bij 20°C	Ohm	1,91			0,788
Ventilator	/	Axiaal			
Hoeveelheid	/	1			
Diameter	mm	405			510
Aantal bladen	/	3			
Motor	/	DC-omvormer			
Hoeveelheid	/	1			
Rotatiesnelheid	Tr/min	600--700	600--800	850--950	600--850
Snelheid Stille modus	Tr/min	400	400	400	300
Geluidsrukniveau op 1m	dB(A)	35	43	43	46
Geluidsrukniveau op 10m	dB(A)	18	25	25	29
Netto afmetingen van de eenheid (B-I-H)	mm	1040 / 425 / 615			1130 / 460 / 780
Gewicht	kg	42	45	46	60

(*) Controleer de referenties van de machine aan de hand van de correspondentietabel (zie etiket op de omslag van de handleiding).



(a) Droge lucht 27°C - Relatieve vochtigheid 78% - Watertoevoertemperatuur 26°C.

(b) Droge lucht 15°C - Relatieve vochtigheid 71% - Watertoevoertemperatuur 26°C

2. TECHNISCHE EIGENSCHAPPEN (vervolg)

2.2 Werkgebied

Gebruik de warmtepomp in volgende temperatuur- en vochtigheidsbereiken om een correct en efficiënt te garanderen.

	Verwarmingsmodus 	Afkoelingsmodus 
Buitentemperatuur	-7°C – +35°C	+7°C – +43°C
Watertemperatuur	+12°C – +32°C	+8°C – +40°C
Relatieve vochtigheid	< 80%	< 80%
Instelbereik van de gewenste waarde	+15°C – +32°C	+8°C – +32°C



Als de temperatuur of de vochtigheid niet aan deze voorwaarden voldoet, kunnen beveiligingen losraken en kan de warmtepomp niet meer werken.



De maximale verwarmingstemperatuur is 32°C om beschadiging van de liners te voorkomen. Hayward wijst alle aansprakelijkheid af in geval van gebruik boven 32°C.

2. TECHNISCHE EIGENSCHAPPEN (vervolg)

2.3 Afmetingen

Modellen :

ECLI15MA / ECLI20MA / ECLI30MA*

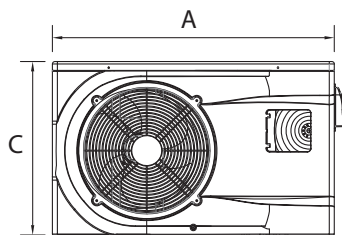
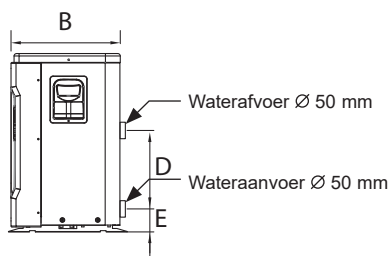

ECLI40MA*

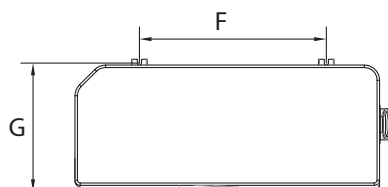
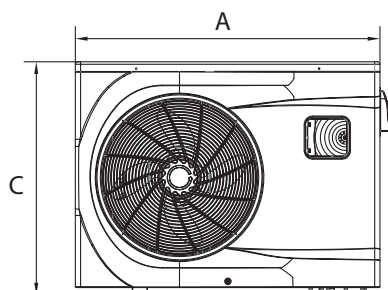
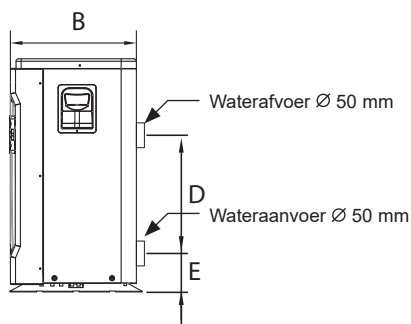

Unit : mm

Modell(*)	ECLI15MA / ECLI20MA / ECLI30MA	ECLI40MA
A	956	1002
B	360	415
C	605	767
D	350	350
E	98	101
F	545	615
G	380	442

(*) Controleer de referenties van de machine aan de hand van de correspondentietabel (zie etiket op de omslag van de handleiding).

3. INSTALLATIE EN AANSLUITING

3.1 Basisschema

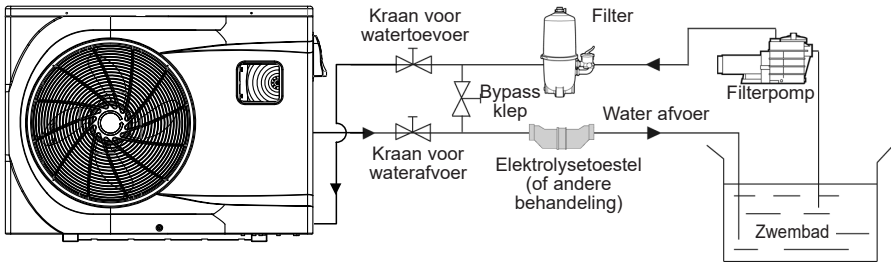

Opmerking : Met de warmtepomp wordt geen randapparatuur of filter meegeleverd. De onderdelen op het schema moeten door de installateur voorzien worden.

3.2 Warmtepomp



Plaats de pomp en openlucht en buiten een gesloten technisch locaal.

De installatie moet beschut staan en de hieronder voorgeschreven minimumafstanden moeten gerespecteerd worden om luchtterugvoer en een minder goede werking van de warmtepomp te voorkomen

Unit: mm

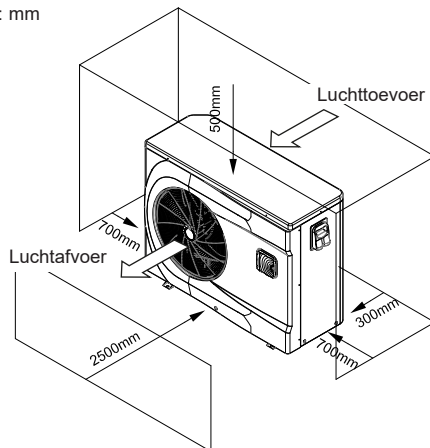

3. INSTALLATIE EN AANSLUITING (vervolg)



Installeer de warmtepomp bij voorkeur op een betonplaat of een bevestigingsstoel die voor dit doeleinde voorzien is en installeer de warmtepomp op de voorziene silentblokken (schroeven en rondellen niet meegeleverd).

De maximumafstand tussen de warmtepomp en het zwembad is 15 meter.

De totale lengte van de hydraulische leidingen is 30 meter.

De bovengrondse en ondergrondse hydraulische kanalen isoleren.

De warmtepomp moet op een minimum afstand van het bassin worden geïnstalleerd conform de NF C 15-100 (dat wil zeggen op 3,5 m van het waterbassin voor Frankrijk) of conform de geldende installatienormen in andere landen.

Installeer de waterpomp niet in de buurt van een warmtebron.

In geval van installatie in regio's waar het geregeld sneeuwt, wordt aangeraden het apparaat overdekt te installeren om te voorkomen dat er zich sneeuw op de verdampers opstapelt.

3.3 Hydraulische aansluiting

De warmtepomp is voorzien van 2 aansluitingen met een diameter van 50 mm. Gebruik PVC-buizen voor de hydraulische leidingen Ø 50 mm. Sluit de watertoevoer van de warmtepomp op de leiding die van de filtergroep komt en sluit daarna de waterafvoer van de warmtepomp op de waterleiding die naar het zwembad loopt (cv tekening hieronder).

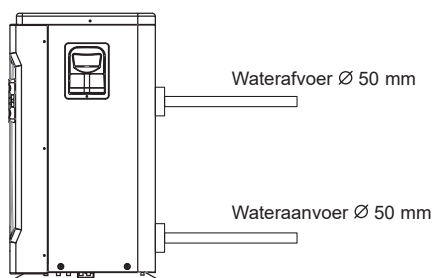

Installeer een bypassklep tussen de in- en uitgang van de warmtepomp.



Als u een automatische distributeur of een elektrolyseapparaat gebruikt, moet deze na de warmtepomp geïnstalleerd worden om de Titanium condensor tegen een te hoge concentratie aan chemische producten te beschermen.



Zorg ervoor dat de bypassklep en de aansluitingen op de aan- en afvoer van het water goed geïnstalleerd zijn om de drainage tijdens de winterperiode, de toegang en de demontage voor onderhoud te vergemakkelijken.

3. INSTALLATIE EN AANSLUITING (vervolg)

3.4 Elektrische aansluiting



De elektrische installatie en de bekabeling van deze uitrusting moeten conform zijn met de plaatselijk geldende normen.

F	NF C15-100	GB	BS7671:1992
D	DIN VDE 0100-702	EW	EVHS-HD 384-7-702
A	ÖVE 8001-4-702	H	MSZ 2364-702/1994/MSZ 10-553 1/1990
E	UNE 20460-7-702 1993, RECBT ITC-BT-31 2002	M	MSA HD 384-7-702.S2
IRL	Wiring Rules + IS HD 384-7-702	PL	PN-IEC 60364-7-702:1999
I	CEI 64-8/7	CZ	CSN 33 2000 7-702
LUX	384-7.702 S2	SK	STN 33 2000-7-702
NL	NEN 1010-7-702	SLO	SIST HD 384-7-702.S2
P	RSIUEE	TR	TS IEC 60364-7-702



Controleer of de elektrische voeding en de netwerkfrequentie overeenstemmen met de vereiste werkstroom, door rekening te houden met de specifieke plaatsing van het toestel en de noodzakelijke stroom om alle andere toestellen die op hetzelfde circuit aangesloten zijn, te voeden.

ECLI15MA / ECLI20MA / ECLI30MA / ECLI40MA(*)
230V ~ +/- 10 % 50 Hz 1 Fase

Bestudeer het overeenkomstige bedradingschema in bijlage.
De aansluitdoos bevindt zich aan de rechterkant van de eenheid. Drie connecties zijn voor de elektrische voeding en twee voor de besturing van de warmtepomp (Bediening).

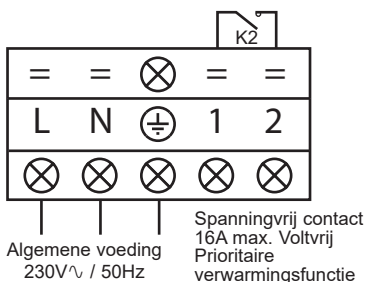

(*) Controleer de referenties van de machine aan de hand van de correspondentietabel (zie etiket op de omslag van de handleiding).

3. INSTALLATIE EN AANSLUITING (vervolg)



De elektrische voedingskabel moet, op gepaste manier, voorzien zijn van een beveiligingszekering van het type motorvoeding (aM) of een stroomonderbreker met D-curve en een differentieelschakelaar 30mA (zie tabel hieronder).

Modellen		ECLI15MA(*)	ECLI20MA(*)	ECLI30MA(*)	ECLI40MA(*)
Elektrische voeding	V/Ph/Hz	230V~ 50Hz	230V~ 50Hz	230V~ 50Hz	230V~ 50Hz
Smeltzekering type aM	A	8 aM	10 aM	16 aM	20 aM
Stroomonderbreker met D-curve	A	8 D	10 D	16 D	20 D
Kabelsectie	mm ²	3G 2,5	3G 2,5	3G 2,5	3G 4

(*) Controleer de referenties van de machine aan de hand van de correspondentietabel (zie etiket op de omslag van de handleiding).



Gebruik een voedingskabel van het type RO 2V / R 2V of equivalent.



De kabelsecties worden gegeven voor een maximale lengte van 25 m. Deze moeten echter worden gecontroleerd en aangepast afhankelijk van de installatieomstandigheden.



Schakel altijd de hoofdschakelaar uit alvorens de elektriciteitsdoos te openen.

3.5 Eerste gebruik

Opstartprocedure - zodra de installatie beëindigd is, moet u de volgende stappen volgen en respecteren :

- 1) Draai de ventilatoren handmatig om te controleren of deze met de hand gedraaid kunnen worden en of het blad op de motorboom bevestigd is.
- 2) Controleer of de eenheid correct op de hoofdvoeding aangesloten is (zie bedradingsschema in bijlage).
- 3) Activeer de filterpomp.
- 4) Controleer of alle waterkleppen openstaan en dat het water naar de eenheid loopt alvorens in verwarming of koeling opstart.
- 5) Controleer of de drainageleiding correct vastgemaakt is en niet verstopt is.
- 6) Schakel de elektrische voeding van de eenheid in en druk daarna op de Start/Stop-knop  op het controlepaneel.

3. INSTALLATIE EN AANSLUITING (vervolg)

- 7) Zorg ervoor dat de alarm- of vergrendelingsymbolen niet verschijnen. Raadpleeg, indien nodig, de gids voor het oplossen van problemen (zie § 6.4).
- 8) Leg het waterdebiet vast met behulp van de bypassklep (zie § 3.6 en 2.1), zoals respectievelijk vastgelegd is voor ieder model, zodat er een temperatuurverschil van 2°C is tussen het Binnenkomend en Uitgaand water.
- 9) Wanneer het toestel enkele minuten gedraaid heeft, controleer dan dat de lucht die eruit komt,afgekoeld is (tussen 5° en 10°).
- 10) Stop de filterpomp terwijl de eenheid blijft draaien. De eenheid moet automatisch stoppen en de foutcode E03 weergeven.
- 11) Laat de eenheid en de zwembadpomp 24u op 24u draaien todat de gewenste watertemperatuur bereikt is. Wanneer het binnenkomend water de gewenste temperatuur bereikt heeft, zal de eenheid stilvallen. Ze zal automatsch opstarten (als de zwembadpomp in werking is) als de temperatuur van het zwembad 0.5°C lager is dan de gewenste temperatuur.

Debietschakelaar - De eenheid is voorzien van een debietschakelaar die de warmtepomp inschakelt wanneer de filterpomp van het zwembad in werking is, en uitschakelt wanneer de de filterpomp stopt. Bij onvoldoende water zal de alarmcode E03 op de schakelaar getoond worden (Zie § 6.4).

Vertraging - De eenheid vertoont een vertraging van 3 minuten om de onderdelen van het besturingscircuit te beschermen en om onregelmatige opstart en storingen van de contactor te vermijden. Dankzij deze vertraging start de eenheid automatisch op ongeveer 3 minuten na een stroomonderbreking. Zelfs een korte stroomonderbreking zal de uitgestelde start activeren.

3. INSTALLATIE EN AANSLUITING (vervolg)

3.6 Instelling van het waterdebiet

Terwijl de kleppen voor binnenkomend en uitgaand water openstaan, moet u de bypassklep afstellen om een temperatuurverschil van 2°C tussen het binnenkomend en uitgaand water te bekomen (zie basisschema §3.1). U kan de instelling controleren voor de temperaturen van het binnenkomend en uitgaand water te visualiseren op het controlepaneel.



Opmerking : De opening van de bypassklep zorgt voor een lager waterdebiet.
De sluiting van de bypassklep zorgt voor een hoger waterdebiet

4. GEBRUIKERSINTERFACE

4.1 Algemene voorstelling

De warmtepomp is uitgerust met een digitaal besturingspaneel met touchscreen, elektrisch aangesloten en voorgeïnstalleerd in verwarmingsmodus.

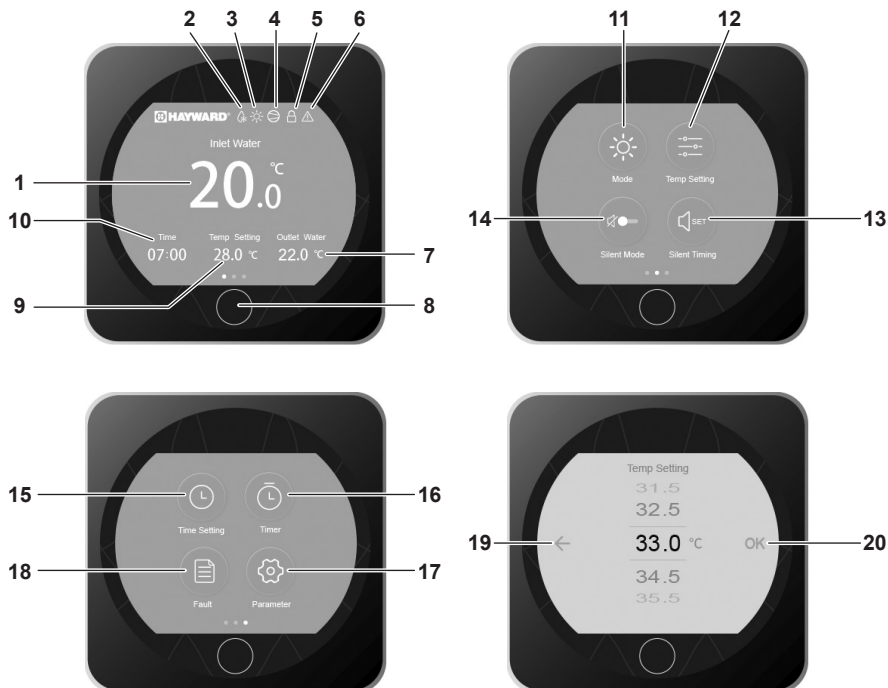

Legende

1	Temperatuur wateraanvoer
2	Modus de-icing
3	Werkwijze
4	Indicatielampje voor de werking van de compressor
5	Het scherm vergrendelen
6	Alarm
7	Temperatuur waterafvoer
8	Aan/uit/terug
9	Gewenste temperatuur
10	Tijd

11	Selectie van de werkingsmodus
12	Instelwaarde aanpassen
13	Instelling timer stille modus
14	Stille modus inschakelen
15	Datum en tijd instellen
16	Timers aan/uit instellen
17	Geavanceerde instellingen
18	Lijst met defecten
19	Terug (zonder bevestiging)
20	Bevestiging

4. GEBRUIKERSINTERFACE (vervolg)

OFF/STOP-modus

Wanneer de warmtepomp wordt uitgeschakeld (in standby-modus), verschijnt het label OFF op het display.

Een zwarte display geeft aan dat de warmtepomp gestopt is, in deze modus is het mogelijk om parameters in te stellen.



ON/BEDRIJFS-modus

Wanneer de warmtepomp in bedrijf is of in een ingestelde stand staat (het bereiken van de ingestelde waarde), wordt het display blauw.



Om over te schakelen van OFF naar ON modus en vice versa, drukt u op de  knop.

4. GEBRUIKERSINTERFACE (vervolg)

4.2 Instelling Datum en Tijd

De datum en tijd voor de ON of OFF modus kunnen worden ingesteld.



- Druk 1 maal op  op om terug te keren naar het hoofdscherm.

4. GEBRUIKERSINTERFACE (vervolg)

4.3 De timers aan/uit instellen

De instellingen van deze functie zijn noodzakelijk zodra u uw warmtepomp binnen een kortere termijn dan vastgelegd door de filterklok wilt gebruiken. Op die manier kunt u een uitgestelde start en een vroegtijdige uitschakeling programmeren of eenvoudigweg een periode waarin de pomp niet gebruikt mag worden.

U kunt een timer Start en een timer Stop programmeren.
Het instellingsinterval is van «van uur tot uur».



4. GEBRUIKERSINTERFACE (vervolg)



Helder blauw = Geactiveerd
Grijs = gedeactiveerd

- Druk 2 maal op  op om terug te keren naar het hoofdscherm.

4. GEBRUIKERSINTERFACE (vervolg)

4.4 Instelwaarde aanpassen

De instelling van de instelwaarde kan in de AAN- of UIT-stand worden uitgevoerd met een nauwkeurigheid van 0,5°C.



- Druk 1 maal op  op om terug te keren naar het hoofdscherm.



Het is aangewezen nooit de 30°C te overschrijden om te vermijden dat de liners verkleuren.

4. GEBRUIKERSINTERFACE (vervolg)

4.5 Het touchscreen vergrendelen en ontgrendelen.

Het scherm kan worden vergrendeld en ontgrendeld in de ON of OFF modus.



Vergrendeling ingeschakeld



Vergrendeling uitgeschakeld

4. GEBRUIKERSINTERFACE (vervolg)

4.6 Instellen van de SILENCE functie

In de stille modus werkt de warmtepomp in de economische modus en heel stil als de verwarmingsbehoefte laag is (handhaven van de temperatuur van het bassin of indien een ultrastille werking nodig is).

Deze functie kan zowel handmatig als met behulp van een timer geactiveerd/ gedeactiveerd worden.

Inschakelen / Uitschakelen



Stille modus uitgeschakeld



Stille modus geactiveerd



- Druk 1 maal op  op om terug te keren naar het hoofdscherm.

4. GEBRUIKERSINTERFACE (vervolg)

De timer voor de STILLE-modus instellen



4. GEBRUIKERSINTERFACE (vervolg)



- Druk 2 maal op  op om terug te keren naar het hoofdscherm.



Het instellingsinterval is van «van uur tot uur».
Als de Timer is geactiveerd, is deze 7 dagen per week actief.

5. ONDERHOUD EN OVERWINTERING

5.1 Onderhoud

1 keer per jaar moeten er onderhoudswerken plaatsvinden om de levensduur en een goede werking van de warmtepomp te kunnen garanderen.

- Poets de verdamper met een zachte borstel, een luchtstraal of met water (**Opgelet, gebruik nooit een hogedrukreiniger**).
- Controleer of de condensaten goed afgevoerd worden.
- Controleer of de elektrische en hydraulische aansluitingen goed afsluiten.
- Controleer de hydraulische dichting van de condensor.
- De waterdichtheid van het koelcircuit **door een erkende professional** laten controleren met een lekdetector.



Voor ieder onderhoud moet de warmtepomp ontkoppeld worden van elke elektrische bron. Onderhoud mag enkel door een gekwalificeerde en bevoegde installateur gebeuren die gewend is met koelmiddelen om te gaan.

5.2 Overwintering

- Zet de warmtepomp in Modus "OFF".
- Ontkoppel de voeding van de warmtepomp.
- Maak de condensor leeg met behulp van de aflatopening om schade te vermijden. (belangrijk risico bij bevriezing).
- Sluit de "by-pass"-klep af en schroef de aansluitingen op de in-/uitlaat los.
- Voer het resterende water in de condensor door middel van een luchtpistool af.
- Sluit de watertoevoer en -afvoer van de warmtepomp af om te vermijden dat vreemde voorwerpen binnendringen.
- Bedek de warmtepomp met de meegeleverde overwinteringshoes.



Eender welke schade veroorzaakt door een slechte overwintering, zorgt ervoor dat de garantie geannuleerd wordt.

6. BIJLAGEN

6.1 Elektrische schema's

ECLI15MA / ECLI20MA / ECLI30MA (*)

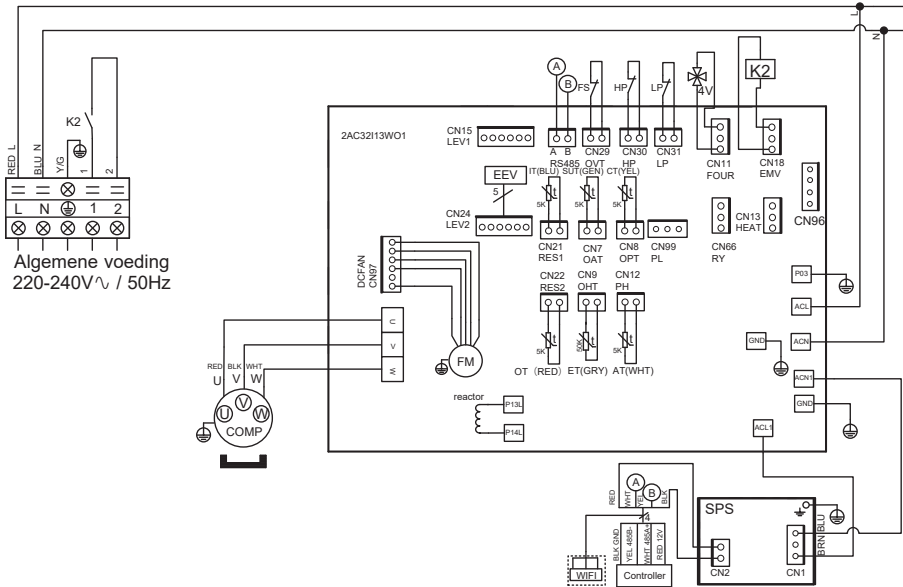

OPMERKINGEN

- | | |
|---|--|
| AT : LUCHTTEMPERATUURSENSOR | LP : LAGEDRUKSCHAKELAAR |
| COMP : COMPRESSOR | OT : TEMPERATUURSENSOR VOOR BUITENGAAND WATER |
| CT : CONDENSATIETEMPERatuur SENSOR | SUT : AANZUIGTEMPERATUURSENSOR |
| EEV : ELEKTRONISCHE DRUKREGELAAR | 4V : 4-WEGSKRAAN |
| FM : VENTILATORMOTORR | K2 : VOLTURIJ CONTACT MAX 16 A |
| FS : WATERDETECTOR | ET : TEMPERATUURSENSOR OPSTUWING |
| HP : HOGEDRUKSCHAKELAAR | [] : OPTIEONEEL |
| IT : TEMPERATUURSENSOR VOOR BINNENKOMEND WATER | |

(*) Controleer de referenties van de machine aan de hand van de correspondentietabel (zie etiket op de omslag van de handleiding).

6. BIJLAGEN (vervolg)

ECLI40MA (*)

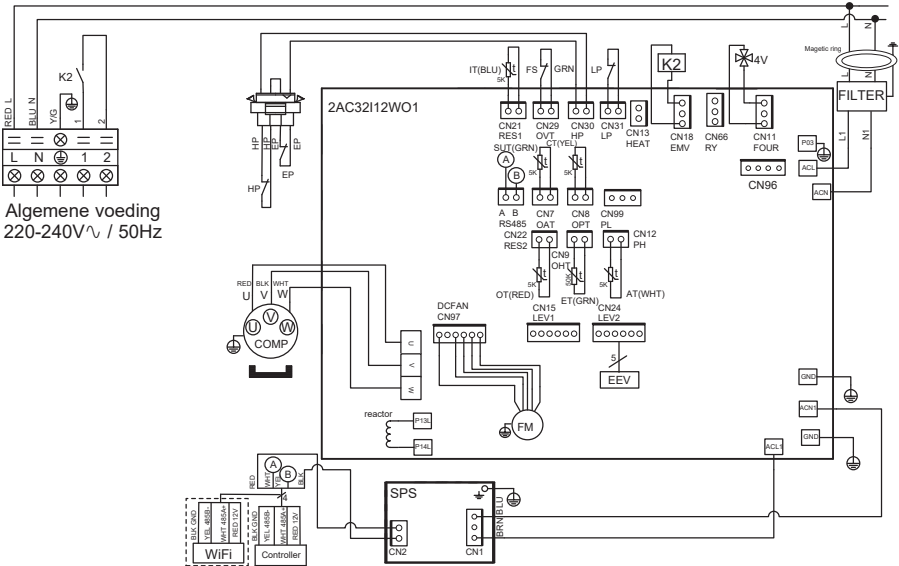

OPMERKINGEN

- | | |
|---|--|
| AT : LUCHTTEMPERATUURSENSOR | LP : LAGEDRUKSCHAKELAAR |
| COMP : COMPRESSOR | OT : TEMPERATUURSENSOR VOOR BUITENGAAND WATER |
| CT : CONDENSATIETEMPERatuur SENSOR | SUT : AANZUIGTEMPERATUURSENSOR |
| EEV : ELEKTRONISCHE DRUKREGELAAR | 4V : 4-WEGSKRAAN |
| FM : VENTILATORMOTORR | K2 : VOLTVRIJ CONTACT MAX 16 A |
| FS : WATERDETECTOR | ET : TEMPERATUURSENSOR OPSTUWING |
| HP : HOGEDRUKSCHAKELAAR | [] : OPTIONEEL |
| IT : TEMPERATUURSENSOR VOOR BINNENKOMEND WATER | |

(*) Controleer de referenties van de machine aan de hand van de correspondentietabel (zie etiket op de omslag van de handleiding).

6. BIJLAGEN (vervolg)

6.2 Aansluitingen prioriteit verwarming eenfasepomp

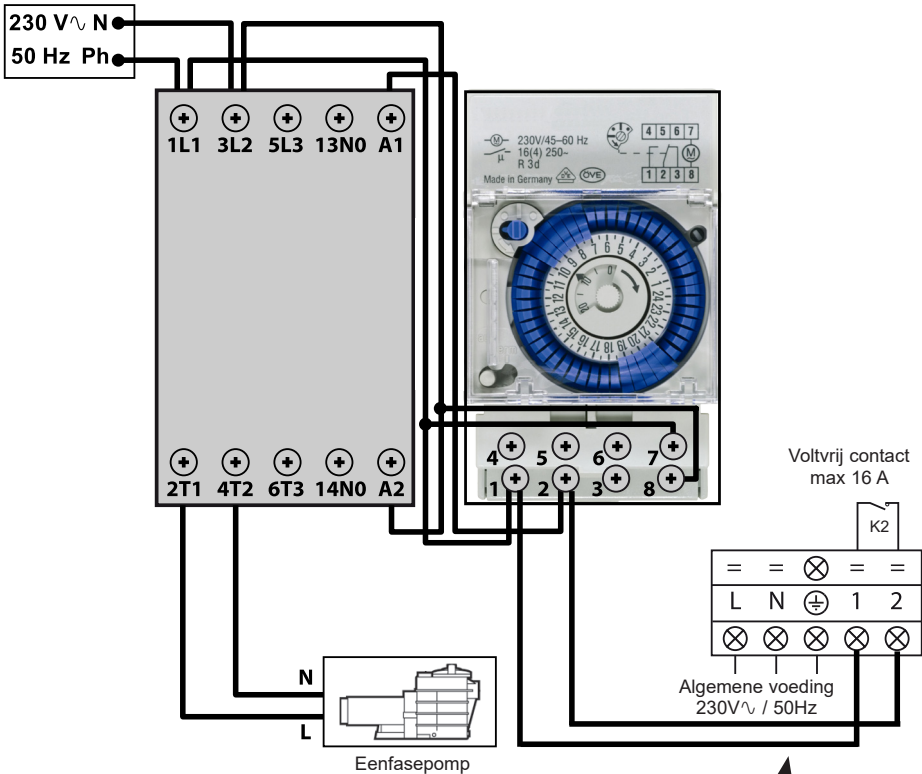

De zuilen 1-2 leveren een spanningvrij contact, zonder polariteit 230 V \sim / 50 Hz.

Sluit de zuilen 1 en 2 met kabels aan zoals op het schema hierboven is aangegeven zodat de werking van de filterpomp wordt ingesteld op een cyclus van 2 minuten per uur als de temperatuur van het bassin lager is dan aanbevolen.

 De voeding van de filterpomp nooit direct aansluiten op de zuilen 1 en 2.



Opzettelijk leeg gelaten pagina

6. BIJLAGEN (vervolg)

6.3 Opengewerkte tekeningen en onderdelen / Addendum

ECLI15MA / 20MA / 30MA / 40MA (*)

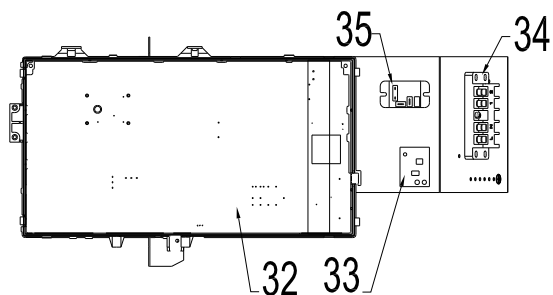
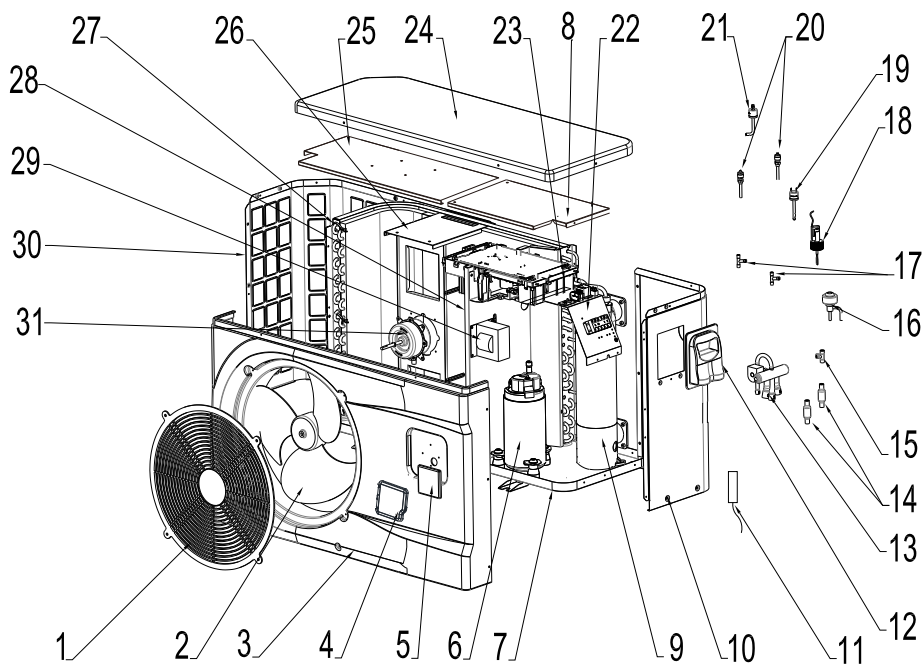

6. BIJLAGEN (vervolg)

Nr.	Omschrijving	Ref.	ECLI15MA*	ECLI20MA*	ECLI30MA*	ECLI40MA*
1	Bescheringsrooster ventilator	HWX20000220245	✓	✓	✓	n.v.t.
		HWX20000220369	n.v.t.	n.v.t.	n.v.t.	✓
2	Ventilatorblad	HWX301030000006	✓	✓	✓	n.v.t.
		HWX301030000001	n.v.t.	n.v.t.	n.v.t.	✓
3	Paneel Voor	HWX809000099	✓	✓	✓	n.v.t.
		HWX80900100	n.v.t.	n.v.t.	n.v.t.	✓
4	Bescheringsdeur	HWX80900320	✓	✓	✓	✓
5	LED regulator	HWX82300038	✓	✓	✓	✓
6	Compressor	HWX20000110448	✓	✓	✓	n.v.t.
	Compressor	HWX80100003	n.v.t.	n.v.t.	n.v.t.	✓
7	/	/	/	/	/	/
8	/	/	/	/	/	/
9	Titaancondensor/pvc	HWX80600037	✓	n.v.t.	n.v.t.	n.v.t.
		HWX32012120061	n.v.t.	✓	n.v.t.	n.v.t.
		HWX32012120056	n.v.t.	n.v.t.	✓	n.v.t.
		HWX80600096	n.v.t.	n.v.t.	n.v.t.	✓
10	Rechterpaneel	HWX80700445	✓	✓	✓	n.v.t.
		HWX80700314	n.v.t.	n.v.t.	n.v.t.	✓
11	Aspiratiesonde compressor 5k-560mm	HWX83000044	✓	✓	✓	n.v.t.
	Aspiratiesonde compressor 5k-760mm	HWX83000053	n.v.t.	n.v.t.	n.v.t.	✓
	Luchttemperatuursonde 5k-350mm	HWX83000049	✓	✓	✓	✓
	Waterafvoer sonde 5k-410mm	HWX83000050	✓	✓	✓	✓
	Sensor voor binnenkomend water 5k-850mm	HWX83000052	✓	✓	✓	✓
	Ontlading compressorsonde 50k-660mm	HWX83000026	n.v.t.	✓	✓	✓
	Ontdooisensor 5k-680mm	HWX83000051	✓	✓	✓	n.v.t.
	Ontdooisensor 5k-1040mm	HWX83000045	n.v.t.	n.v.t.	n.v.t.	✓
12	Elektrische toegangsopening	HWX320922029	✓	✓	✓	✓
13	4-wegskraan	HWX20041437	✓	✓	✓	✓
14	Filter ø9.7-ø9.7 (Ø19)	HWX20000140178	✓	✓	✓	n.v.t.
	Filter ø9.7-ø9.7 (Ø28)	HWX20041444	n.v.t.	n.v.t.	n.v.t.	✓
15	T-schakelaar ø9.52-2 x ø6.35(T) x 1.0	HWX30403000002	✓	✓	✓	✓
16	Elektronisch reduceerventiel	HWX20000140570	✓	✓	✓	n.v.t.
		HWX81000013	n.v.t.	n.v.t.	n.v.t.	✓
17	T-schakelaar ø6.5-2 x ø6.5(T) x 0.75	HWX20001460	✓	✓	✓	✓
18	Detector waterdebiet	HWX83000012	✓	✓	✓	✓
19	Drukregelaar lage druk NO 0.30MPa/0.15MPa	HWX20000360157	✓	✓	✓	✓
20	Drukafsluiter 40mm 1/2»	HWX20000140150	✓	✓	✓	✓
21	Drukregelaar hoge druk NC 3.2MPa/4.4MPa	HWX20013605	✓	✓	✓	✓
22	/	/	/	/	/	/
23	/	/	/	/	/	/
24	Paneel bovenaan	HWX80900055	✓	✓	✓	n.v.t.
		HWX301090200806	n.v.t.	n.v.t.	n.v.t.	✓
25	/	/	/	/	/	/
26	Motorsteun	HWX80700218	✓	✓	✓	n.v.t.
		HWX80700248	n.v.t.	n.v.t.	n.v.t.	✓

(*) Controleer de referenties van de machine aan de hand van de correspondentietabel (zie etiket op de omslag van de handleiding).

6. BIJLAGEN (vervolg)

ECLI15MA / 20MA / 30MA / 40MA (*)

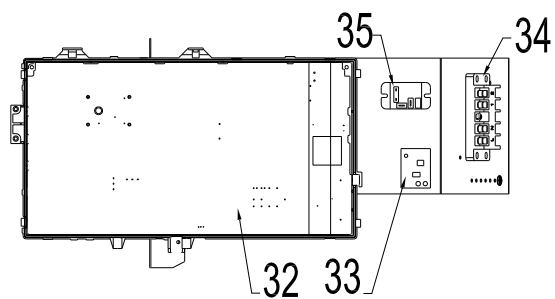
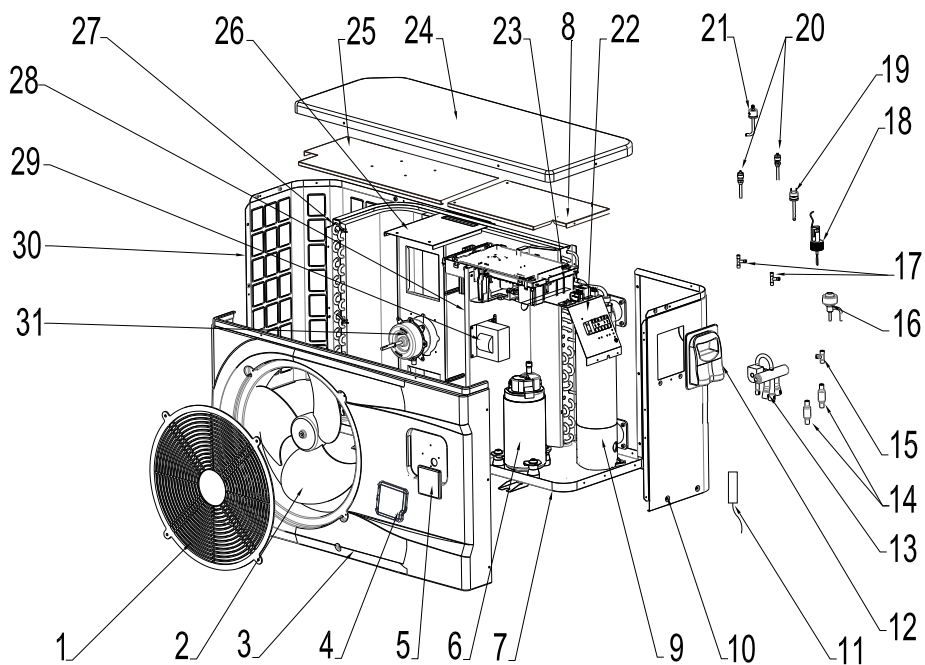

6. BIJLAGEN (vervolg)

Nr.	Omschrijving	Ref.	ECLI15MA*	ECLI20MA*	ECLI30MA*	ECLI40MA*
27	Verdamper met lamellen	HWX301060202502	✓	n.v.t.	n.v.t.	n.v.t.
		HWX80600042	n.v.t.	✓	n.v.t.	n.v.t.
		HWX80600043	n.v.t.	n.v.t.	✓	n.v.t.
		HWX80600044	n.v.t.	n.v.t.	n.v.t.	✓
28	/	/	/	/	/	
29	Spoel 16A 50Hz 5mH	HWX82500006	✓	✓	✓	n.v.t.
	Spoel 20A 50Hz 5.2mH	HWX82500005	n.v.t.	n.v.t.	n.v.t.	✓
30	Linkerpaneel	HWX80700446	✓	✓	✓	n.v.t.
		HWX80700315	n.v.t.	n.v.t.	n.v.t.	✓
31	Motor ventilator DC	HWX80200018	✓	✓	✓	n.v.t.
		HWX20000330132	n.v.t.	n.v.t.	n.v.t.	✓
32	Elektronische driver-kaart	HWX82300052	✓	✓	✓	n.v.t.
		HWX82300007	n.v.t.	n.v.t.	n.v.t.	✓
33	Transformator 230V~/12DC	HWX82600008	✓	✓	✓	✓
34	Aansluitblok L-N-GND -5 aansluitingen 4mm ²	HWX40003901	✓	✓	✓	✓
35	Relais K2	HWX20000360297	✓	✓	✓	✓

(*) Controleer de referenties van de machine aan de hand van de correspondentietabel (zie etiket op de omslag van de handleiding).

6. BIJLAGEN (vervolg)

6.4 Gids voor het probleemoplossing





Sommige handelingen mogen enkel door een bevoegd techniker uitgevoerd worden.

In geval van een storing aan de warmtepomp verschijnt het  -symbool in de linkerbovenhoek van het display.

In geval van een defect, worden de volgende indicaties op het scherm weergegeven:



Na het oplossen van het probleem wordt de fout automatisch bevestigd, de driehoek verdwijnt.

- Om de foutenlijst te wissen, op  .
- Druk 2 maal op  op om terug te keren naar het hoofdscherm.

6. BIJLAGEN (vervolg)

Probleem	Foutcodes	Omschrijving	Oplossing
Inlaat watertemperatuur sensor fout	P01	De sensor is open of in kortsluiting	Controleer de CN21/RES1-connector op de printplaat en verleng of vervang de sensor.
Uitlaat watertemperatuur sensor fout	P02		Controleer de N22/RES2-connector op de printplaat en verleng of vervang de sensor.
Omgevingstemperatuursensor fout	P04		Controleer de CN12/PH-connector op de printplaat en verleng of vervang de sensor.
Ontdooisensor fout	P05		Controleer de CN8/OPT-connector op de printplaat en verleng of vervang de sensor.
Defect aspiratiesonde compressor	P07		Controleer de CN7/OAT-connector op de printplaat en verleng of vervang de sensor.
Defect aanzuigsonde Compressor	P081		Controleer de CN9/OHT-connector op de printplaat en verleng of vervang de sensor.
Overdrukbescherming	E01	De sensor is open of in kortsluiting	<p>Controleer de CN30 / HP-connector op het bord of vervang de sensor</p> <p>Waterdebiet controleren</p> <p>Waterdebietdetector controleren</p> <p>Opening van de kleppen controleren</p> <p>Bypass controleren</p> <p>De verdamper op vervuiling controleren</p> <p>Te hoge watertemperatuur</p> <p>Probleem met niet-condenseerbare stoffen, verwijder vloeistof en lucht uit het koelcircuit</p> <p>Te veel vloeistof aanwezig, verwijder de vloeistof in een fles</p>
Onderdrukbescherming	E02	De sensor is open of in kortsluiting	<p>De AI/DI03 aansluiting op de kaart controleren of de sensor vervangen</p> <p>Controleer de lagedrukregelaar en de druk van het koelcircuit om na te gaan of er een lek is.</p> <p>Te laag luchtdebiet, de rotatiesnelheid van de ventilator controleren</p> <p>De verdamper op vervuiling controleren</p>
Debietmeter fout	E03	De sensor is open of in kortsluiting	<p>De AI/DI02 aansluiting op de kaart controleren of de sensor vervangen</p> <p>Te weinig water, de werking van de filterpomp controleren</p> <p>Opening van de stopkleppen controleren</p> <p>Bypass controleren</p>

6. BIJLAGEN (vervolg)

Probleem	Foutcodes	Omschrijving	Oplossing
Temperatuurverschil tussen Aanvoer/ Afvoer > 13°C	E06	Alleen in Koude modus toepasbaar	Te weinig water, de werking van de filterpomp controleren
			Opening van de stopkleppen controleren
			Bypass controleren
Antivriesbescherming Koude Modus	E07	Temperatuur waterafvoer < 4°C	De warmtepomp stoppen, de condensor leegmaken, risico op bevriezing
Debietmeter fout	E08	Geen communicatie tussen de elektronische kaart en de gebruikersinterface	Aansluitingen en connectoren controleren - zie elektrisch schema
Antivriesbescherming van niveau 1	E19	< 2°C Watertemperatuur < 4° en luchttemperatuur < 0°	Schakel de warmtepomp uit, maak de condensor leeg om bevriezing te voorkomen, de pomp start standaard de filterpomp om bevriezing te voorkomen
Antivriesbescherming van niveau 2	E29	Watertemperatuur < 2° en luchttemperatuur < 0°	Schakel de warmtepomp uit, maak de condensor leeg om bevriezing te voorkomen, de pomp start standaard de filterpomp en de warmtepomp om bevriezing te voorkomen.
Fout in de ventilatormotor	F031	Motor geblokkeerd of verbinding mislukt	Controleer de vrije rotatie; controleer het CN97/DCFan-aansluitsysteem; vervang de motor.
Fout in de ventilatormotor	F051	Verbindingsfout	DCFAN/CN97-aansluiting controleren; motor vervangen
Buitentemperatuur te laag	TP	Bedrijfslimiet bereikt	Warmtepomp uitschakelen

6. BIJLAGEN (vervolg)

6.5 Garantie

GARANTIEVOORWAARDEN

Alle HAYWARD-producten vallen onder garantie in geval van fabrieks- of materiaalfouten gedurende twee jaar vanaf de aankoopdatum. Elke garantieaanvraag moet samen met een aankoopbewijs met datum ingediend worden. Wij dringen er dus op aan dat u uw factuur bewaart. De HAYWARD-garantie is beperkt tot reparatie of vervanging, bepaald door HAYWARD, van de defecte toestellen zolang ze op een normale wijze en volgens de voorschriften die in de handleiding vermeld, gebruikt zijn, het apparaat niet aangepast is en enkel gebruikt is in met HAYWARD componenten en onderdelen. Schade veroorzaakt door vrieskou en chemische agensen vallen niet onder garantie. Alle andere kosten (transport, werkuren...) worden niet door de garantie gedekt.

HAYWARD kan niet verantwoordelijk gesteld worden voor eender welke directe of indirecte schade veroorzaakt tijdens de installatie, aansluiting of onjuist gebruik van een product.

Om een garantie aan te vragen en herstel of vervanging van een product te eisen, moet u zich tot uw verdeler wenden. Wij zullen geen enkele retour naar de fabriek aanvaarden zonder een vooraf bekomen schriftelijke goedkeuring. Slijtage valt niet onder garantie.

Opzettelijk leeg gelaten pagina

FULL INVERTER R32

UNITÀ DI RISCALDAMENTO A POMPA DI CALORE PER PISCINE

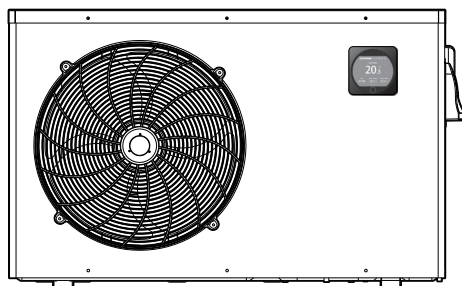

Manuale d'Uso e di Installazione

INDICE

1. INTRODUZIONE	1
2. SPECIFICHE TECNICHE	4
2.1 Dati tecnici della pompa a calore	4
2.2 Soglie di funzionamento	5
2.3 Dimensioni	6
3. INSTALLAZIONE E COLLEGAMENTO	7
3.1 Schema di principio	7
3.2 Pompa di calore	7
3.3 Collegamento idraulico	8
3.4 Collegamento Elettrico	9
3.5 Primo avviamento	10
3.6 Regolazione della portata d'acqua	12
4. INTERFACCIA UTENTE	13
4.1 Presentazione generale	13
4.2 Impostazione di Data e Ora	15
4.3 Regolazione dei Timer ON/OFF	16
4.4 Regolazione del valore prefissato	18
4.5 Blocco e sblocco del touch screen	19
4.6 Configurazione della funzione SILENCE	20
5. MANUTENZIONE E SVERNAMENTO	23
5.1 Manutenzione	23
5.2 Svernamento	23
6. APPENDICI	24
6.1 Schemi Elettrici	24
6.2 Collegamenti priorità riscaldamento pompa monofase	26
6.3 Esplosi e parti di ricambio / Addendum	28
6.4 Guida alla Risoluzione dei Problemi	32
6.5 Garanzia	35

Leggere attentamente e riporre in luogo facilmente accessibile per la consultazione.

La presente documentazione deve essere consegnata al proprietario della piscina, il quale dovrà conservarla in un luogo sicuro.

1. INTRODUZIONE

Vi ringraziamo per aver acquistato la nostra pompa a calore per piscina Hayward. La pompa a calore Hayward FULL INVERTER è stata appositamente studiata secondo severe norme di fabbricazione, allo scopo di fornire il più elevato livello di qualità possibile.

Le pompe a calore Hayward vi offriranno eccezionali prestazioni durante tutta la stagione dei bagni adattando la potenza, i consumi elettrici ed il livello acustico alle esigenze di riscaldamento della vostra piscina, grazie al circuito logico di controllo FULL INVERTER.



Leggere attentamente le istruzioni contenute in questo manuale prima dell'uso

Le pompe a calore Hayward sono esclusivamente destinate al riscaldamento dell'acqua della piscina. Non vanno usate per altri scopi.

Il presente manuale contiene tutte le informazioni necessarie riguardo all'installazione, alla risoluzione delle anomalie e alla manutenzione della pompa.

Leggere attentamente il manuale prima di aprire la pompa o di effettuare operazioni di manutenzione sulla stessa. Il costruttore della pompa non sarà ritenuto in alcun caso responsabile di eventuali danni fisici subiti da un utente o di eventuali danni subiti dal materiale in seguito ad errori d'installazione, a tentativi di risoluzione di anomalie o ad interventi di manutenzione inutili. Vanno sempre rispettate le istruzioni contenute nel manuale

Il mancato rispetto delle istruzioni annulla la garanzia.

INTRODUZIONE (segue)



Istruzioni di sicurezza



Questo apparecchio contiene R32.

Non usare mai un refrigerante diverso dall'R32. La miscela di altri corpi gassosi con l'R32 rischia di provocare pressioni anormalmente elevate che possono causare guasti o rotture dei tubi e danni fisici alle persone

Non usare mai, durante le riparazioni o le operazioni di manutenzione, tubi di rame dotati di spessore inferiore a 0,8 mm.

La pompa a calore è sotto pressione: occorre, pertanto, evitare, in qualunque caso, di forare i tubi o di effettuare giunzioni brasate. Rischio di esplosione.

Non esporre l'apparecchio alle fiamme, alle scintille o ad altre sorgenti di combustione. La pompa potrebbe esplodere provocando ferite gravi o addirittura mortali.

- Quando non viene usata, la pompa a calore va riposta in un locale sufficientemente ventilato, dotato di una superficie al suolo di A_{\min} (m²) calcolata secondo la seguente formula : $A_{\min} = (M/(2.5 \times 0.22759 \times h_0))^2$
M corrisponde alla carica di refrigerante in kg contenuta nell'apparecchio, mentre h₀ corrisponde all'altezza di stoccaggio. Se la pompa viene riposta a livello del suolo h₀ = 0,6 m.
- La pompa a calore va installata esclusivamente all'esterno degli edifici.
- L'impianto va installato unicamente da personale qualificato.
- Non installare la pompa a calore su un supporto suscettibile di amplificare le vibrazioni prodotte dalla stessa.
- Verificare che le dimensioni del supporto previsto per l'impianto siano adeguate rispetto al peso dell'apparecchiatura
- Non installare la pompa in un luogo suscettibile di amplificarne il livello acustico o in cui il rumore prodotto dall'impianto rischi di disturbare i vicini.
- L'allacciamento elettrico va effettuato da un elettricista qualificato, secondo le norme vigenti nel paese in cui è installata la pompa cfr. § 3.4.
- Staccare l'alimentazione principale e il sezionatore prima di effettuare qualunque intervento. Qualunque distrazione può causare un'elettrocuzione.
- Prima di procedere all'installazione, verificare che il cavo di terra non sia tagliato o scollegato.

INTRODUZIONE (segue)

- Collegare e serrare correttamente il cavo d'alimentazione elettrica. Un collegamento non correttamente effettuato può danneggiare i componenti elettrici.
- L'esposizione della pompa a calore all'acqua o all'umidità può provocare un'elettrocuzione. State molto attenti.
- Se riscontrate un difetto o un'anomalia, non installate la pompa e chiamate immediatamente il rivenditore.
- La manutenzione e le diverse operazioni vanno effettuate con la frequenza e nei momenti consigliati dal manuale.
- Le riparazioni vanno effettuate da personale qualificato.
- Usare solo pezzi di ricambio originali.
- Non usare metodi di pulizia diversi da quello consigliato nel manuale.

Avvertenze importanti riguardo al refrigerante utilizzato

Questo prodotto contiene gas serra fluorurati regolamentati dal protocollo di Kyoto. Non sprigionare questo gas nell'atmosfera.

Tipo di refrigerante: R32

Valore GWP(1): 675, valore basato sulla quarta relazione del GIEC.

La quantità di refrigerante basata sulla regolamento n. 517/ 2014 (F-Gas) è indicata sulla piastrina segnaletica dell'apparecchiatura

La vigente normativa europea o locale potrà esigere ispezioni periodiche delle perdite/fughe. Per maggiori informazioni in merito, contattare il distributore locale.

(1) Potenziale di riscaldamento globale

2. SPECIFICHE TECNICHE

2.1 Dati tecnici della pompa a calore

Modelli	CLASSIC FULL INVERTER	ECL115MA(*)	ECL120MA(*)	ECL130MA(*)	ECL140MA(*)
Tensione di alimentazione	V	220V-240V ~ / 1fase/ 50Hz			
Refrigerante	/	R32			
Carica	kg	0,350	0,430	0,480	0,650
Massa in tCO ₂ e	/	0,24	0,29	0,32	0,44
Frequenza di controllo delle perdite	/	Non obbligatoria, ma consigliata una volta all'anno			
Capacità di riscaldamento Min--Max ^(a)	kW	1,62--7,33	2,18--8,97	1,97 --11,66	2,85--17,06
Potenza elettrica assorbita Min--Max ^(a)	kW	0,15--1,17	0,17--1,54	0,16--1,99	0,26--3,13
Corrente nominale di esercizio Min--Max ^(a)	A	1,15--5,32	1,27--6,91	1,08--8,96	1,41--13,69
COP Max--Min (a)	/	11,04--6,30	12,77--5,81	12,57--5,84	11,08--5,45
Capacità di riscaldamento Min--Max ^(b)	kW	1,44--5,36	1,58--6,94	1,79--8,62	2,74--13,08
Potenza elettrica assorbita Min--Max ^(b)	kW	0,24--1,14	0,27--1,53	0,290--1,90	0,428--2,97
COP Max--Min ^(b)	/	5,98--4,69	5,82--4,53	6,17--4,52	6,40--4,40
Corrente nominale ammissibile (CMS)	A	6,4	8,4	10,9	16,6
Calibro del fusibile	aM	8	10	16	20
Interruttore curva D	D	8	10	16	20
Corrente di avviamento	A	< CMS			
Allacciamento idraulico	mm	50mm			
Portata idrica nominale (a)	m ³ /h	3,10	3,80	4,90	7,30
Perdita di carica sull'acqua max	kPa	2,3	2,9	6,4	6,7
Compressore	/	DC Inverter Mitsubishi			DC Inverter Highly
Tipo	/	Doppio rotante			Doppio rotante
Quantità	/	1			
Resistenza di avvolgimento a 20°C	Ohm	1,91			0,788
Ventilatore	/	Assiale			
Quantità	/	1			
Diametro	mm	405			510
Numero di pale	/	3			
Motore	/	DC Inverter			
Quantità	/	1			
Velocità di rotazione	giri/min.	600--700	600--800	850--950	600--850
Velocità modalità silenziosa	giri/min.	400	400	400	300
Livello di pressione acustica a 1 metro	dB(A)	35	43	43	46
Livello di pressione acustica a 10 metri	dB(A)	18	25	25	29
Dimensioni nette dell'unità (L-I-H)	mm	1040 / 425 / 615			1130 / 460 / 780
Peso	kg	42	45	46	60

(*) Verificare i riferimenti delle macchine mediante la tabella delle corrispondenze (vedi etichetta sulla copertina del manuale).



(a) Aria asciutta 27°C - Umidità relativa 78% - Temperatura d'ingresso dell'acqua 26°C.

(b) Aria asciutta 15°C - Umidità relativa 71% - Temperatura d'ingresso dell'acqua 26°C.

2. SPECIFICHE TECNICHE (segue)

2.2 Soglie di funzionamento

Per assicurare un funzionamento sicuro ed efficiente, utilizzare la pompa di calore entro le seguenti soglie di temperatura e umidità.

	Modalità riscaldamento 	Modalità Raffreddamento 
Temperatura esterna	-7°C – +35°C	+7°C – +43°C
Temperatura acqua	+12°C – +32°C	+8°C – +40°C
Umidità relativa	< 80%	< 80%
Soglia di configurazione set point	+15°C – +32°C	+8°C – +32°C



Se la temperatura o l'umidità non soddisfano le suddette condizioni, è possibile che si verifichi l'intervento di dispositivi di sicurezza che impediscano alla pompa di calore di azionarsi.



Per evitare eventuali rischi di deterioramento dei liner la temperatura massima di riscaldamento è limitata a 32°C. Hayward declina ogni responsabilità in caso di uso a temperature superiori a +32°C.

2. SPECIFICHE TECNICHE (segue)

2.3 Dimensioni

Modelli:

ECLI15MA / ECLI20MA / ECLI30MA*

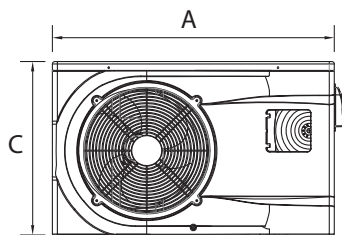
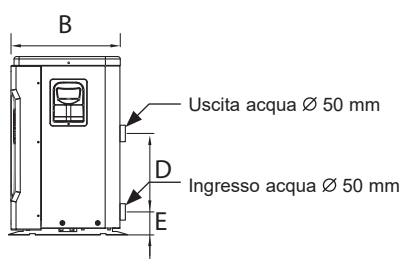

ECLI40MA*

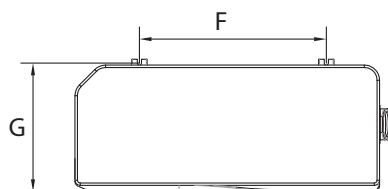
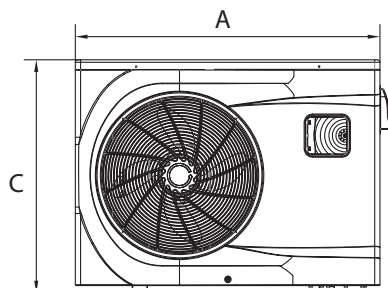
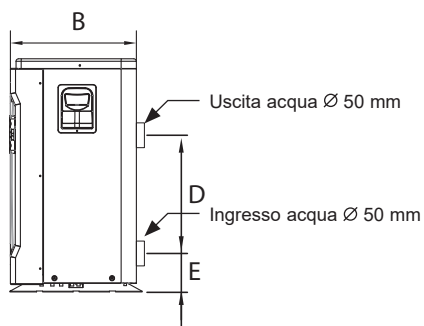

Unità : mm

Modella(*) Numerazione	ECLI15MA / ECLI20MA / ECLI30MA	ECLI40MA
A	956	1002
B	360	415
C	605	767
D	350	350
E	98	101
F	545	615
G	380	442

(*) Verificare i riferimenti delle macchine mediante la tabella delle corrispondenze (vedi etichetta sulla copertina del manuale).

3. INSTALLAZIONE E COLLEGAMENTO

3.1 Schema di principio

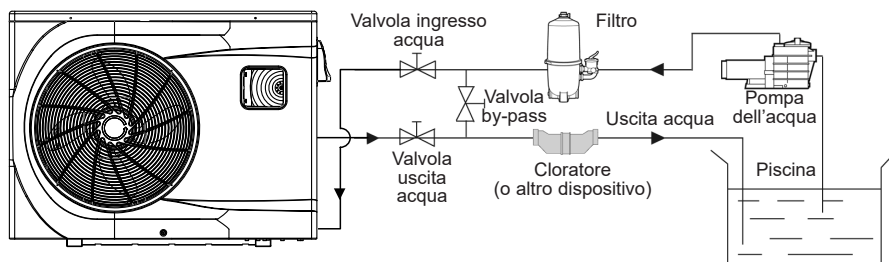

N.B.: L'unità fornita è priva di dispositivi di trattamento o di filtraggio. Gli elementi rappresentati nello schema devono essere forniti dall'installatore.

3.2 Pompa di calore



Installare l'Unità di Riscaldamento a Pompa di Calore per Piscine all'esterno e al di fuori di locali tecnici chiusi.

Installare l'unità in luogo riparato e rispettare le distanze minime sottoindicate, al fine di evitare il rischio di ricircolo dell'aria o eventuali diminuzioni delle prestazioni complessive dell'unità stessa.

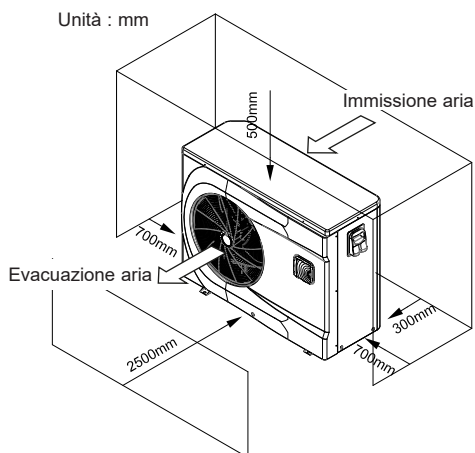

3. INSTALLAZIONE E COLLEGAMENTO (segue)



Preferibilmente, installare l'Unità di Riscaldamento a Pompa di calore su soletta in calcestruzzo alleggerito o su apposito supporto in metallo e montare l'unità sui silentblock in dotazione (bulloneria e rondelle non fornite).

Distanza max. tra l'unità e la piscina: 15 metri.

Lunghezza totale andata/ritorno tubazioni idrauliche: 30 metri.

Isolare le tubazioni idrauliche sia interrate che non interrate.

La pompa di calore deve essere installata a una distanza minima dalla vasca conforme alla norma NF C 15-100 (ossia, per la Francia, a 3,5 m dallo specchio d'acqua) o conforme alle norme relative all'installazione vigenti negli altri paesi.

Non installare la pompa di calore in prossimità di fonti di calore.

In caso d'installazione in regioni nevose, si consiglia di proteggere la macchina per prevenire un eventuale accumulo di neve sull'evaporatore.

3.3 Collegamento idraulico

L'unità è dotata di due raccordi di unione del diametro di 50 mm. Utilizzare tubi in PVC per tubazioni idrauliche Ø 50 mm. Collegare la tubazione per l'ingresso dell'acqua dell'unità alla conduttura proveniente dal gruppo di filtraggio, quindi collegare la tubazione per lo scarico dell'acqua alla conduttura utilizzata per immettere acqua nella piscina (cf. schema seguente).

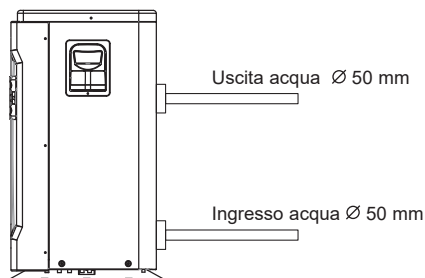

Installare una valvola by-pass tra l'ingresso e l'uscita dell'unità.



Se si utilizza un cloratore o un cloratore automatico, installare tale dispositivo dopo l'unità, al fine di proteggere il condensatore in Titanio da una concentrazione troppo elevata di prodotto chimico.



Per facilitare il drenaggio dell'unità durante la preparazione all'inverno e fornire facile accesso alle operazioni di smontaggio e manutenzione, si consiglia di installare la valvola by-pass e i raccordi di unione in dotazione in corrispondenza dell'ingresso e dell'uscita dell'unità.

3. INSTALLAZIONE E COLLEGAMENTO (segue)

3.4 Collegamento Elettrico



L'installazione elettrica e il cablaggio del presente dispositivo devono essere conformi alle norme d'installazione locali vigenti.

F	NF C15-100	GB	BS7671:1992
D	DIN VDE 0100-702	EW	EVHS-HD 384-7-702
A	ÖVE 8001-4-702	H	MSZ 2364-702/1994/MSZ 10-553 1/1990
E	UNE 20460-7-702 1993, RECBT ITC-BT-31 2002	M	MSA HD 384-7-702.S2
IRL	Wiring Rules + IS HD 384-7-702	PL	PN-IEC 60364-7-702:1999
I	CEI 64-8/7	CZ	CSN 33 2000 7-702
LUX	384-7.702 S2	SK	STN 33 2000-7-702
NL	NEN 1010-7-702	SLO	SIST HD 384-7-702.S2
P	RSIUEE	TR	TS IEC 60364-7-702



Assicurarsi che l'alimentazione elettrica disponibile e la frequenza di rete siano adeguate alla corrente operativa richiesta, tenendo in considerazione l'area di collocazione dell'unità e la corrente necessaria ad alimentare ogni altro dispositivo collegato allo stesso circuito.

ECLI15MA / ECLI20MA / ECLI30MA / ECLI40MA(*)
230V ~ +/- 10 % 50 Hz 1 Fase

Fare riferimento allo schema dell'impianto elettrico corrispondente in appendice.

La scatola di collegamento è posta sul lato destro dell'unità. Tre connessioni sono destinate all'alimentazione elettrica e due al comando della pompa di filtraggio (Asservimento).

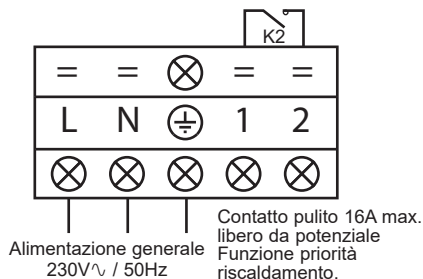

(*) Verificare i riferimenti delle macchine mediante la tabella delle corrispondenze (vedi etichetta sulla copertina del manuale).

3. INSTALLAZIONE E COLLEGAMENTO (segue)



La linea di alimentazione elettrica deve essere opportunamente provvista di salvamotore tipo alimentazione motore (aM) o di interruttore curva D e interruttore differenziale 30mA (v. tabella seguente).

Modelli		ECLI15MA(*)	ECLI20MA(*)	ECLI30MA(*)	ECLI40MA(*)
Alimentazione elettrica	V/Ph/Hz	230V~ 50Hz	230V~ 50Hz	230V~ 50Hz	230V~ 50Hz
Calibro fusibile tipo aM	A	8 aM	10 aM	16 aM	20 aM
Interruttore curva D	A	8 D	10 D	16 D	20 D
Sezione cavo	mm ²	3G 2,5	3G 2,5	3G 2,5	3G 4

(*) Verificare i riferimenti delle macchine mediante la tabella delle corrispondenze (vedi etichetta sulla copertina del manuale).



Utilizzare un cavo di alimentazione tipo RO 2V / R 2V o equivalente.



Le sezioni del cavo sono fornite per una lunghezza massima di 25 m, ma devono comunque essere controllate e adattate a seconda delle condizioni d'installazione.



Staccare sempre l'alimentazione principale prima di aprire la scatola elettrica.

3.5 Primo avviamento

Procedura di avviamento - dopo aver completato l'installazione, attenersi alla seguente procedura:

- 1) Ruotare manualmente i ventilatori per verificarne la libertà di movimento e per assicurarsi che l'elica sia correttamente fissata all'albero motore.
- 2) Assicurarsi che l'unità sia correttamente collegata alla fonte di alimentazione principale (v. schema dell'impianto elettrico in appendice).
- 3) Attivare la pompa di filtraggio.
- 4) Verificare che tutte le valvole dell'acqua siano aperte e che l'acqua fluisca nell'unità prima di avviare qualsiasi processo di riscaldamento o raffreddamento.
- 5) Verificare che la manichetta per lo scarico della condensa sia correttamente collegata e che non vi sia ostacolo al suo funzionamento.
- 6) Attivare l'alimentazione elettrica destinata all'unità, quindi premere il pulsante ON/OFF  sul pannello di controllo.

3. INSTALLAZIONE E COLLEGAMENTO (segue)

- 7) Verificare che non vengano visualizzati i simboli indicanti un allarme o un blocco. Qualora venissero visualizzati tali simboli, consultare l'apposito manuale (v. § 6.4).
- 8) Definire la portata dell'acqua agendo sulla valvola by-pass (v. § 3.6 e 2.1) secondo le indicazioni riportate sulla targhetta identificativa del modello, fino a ottenere una differenza nella temperatura dell'acqua in Ingresso/ Uscita di 2°C.
- 9) Dopo alcuni minuti di utilizzo, assicurarsi che l'aria in uscita sia più fredda (5-10°C).
- 10) Ad unità avviata, spegnere la pompa di filtraggio. L'unità si spegne automaticamente e viene visualizzato il codice errore E03.
- 11) Lasciare l'unità e la pompa piscina in funzione per 24 ore al giorno fino a quando l'acqua non raggiunge la temperatura desiderata. Quando la temperatura dell'acqua in ingresso raggiunge il valore predefinito, l'unità si spegne. L'unità si riavvia automaticamente (fino a quando la pompa della piscina rimane in funzione) quando la temperatura dell'acqua scende di 0,5°C rispetto alla temperatura impostata.

Interruttore di portata - L'unità è dotata di un interruttore di portata che ne regola l'accensione, quando la pompa di filtraggio della piscina è in funzione, e lo spegnimento, quando la pompa di filtraggio della piscina è fuori servizio. Se il livello dell'acqua è troppo basso, il codice d'allarme E03 viene visualizzato sul regolatore (v. § 6.4).

Temporizzazione - L'unità è dotata di un dispositivo di temporizzazione con ritardo di 3 minuti atto a proteggere i componenti del circuito di controllo e a prevenire avvii intempestivi e interferenze concernenti il contattore. Questa funzione riavvia automaticamente l'unità circa 3 minuti dopo ogni interruzione del circuito di controllo. Tale dispositivo si attiva anche in seguito a una breve interruzione di corrente.

3. INSTALLAZIONE E COLLEGAMENTO (segue)

3.6 Regolazione della portata d'acqua

Tenendo aperte le valvole, regolare la valvola by-pass in modo tale da ottenere una differenza di 2° C tra la temperatura dell'acqua in ingresso e la temperatura dell'acqua in uscita (v. schema di principio § 3.1). È possibile accertarsi della corretta regolazione verificando la temperatura dell'acqua in ingresso e in uscita visualizzata sul pannello di controllo.



N.B.: L'apertura della valvola by-pass genera una portata minore e un conseguente aumento del ΔT .
La chiusura della valvola by-pass genera una portata maggiore e una conseguente diminuzione del ΔT .

4. INTERFACCIA UTENTE

4.1 Presentazione generale

L'unità è dotata di un pannello di comando digitale touch screen collegato elettricamente e preimpostato in fabbrica in modalità riscaldamento.

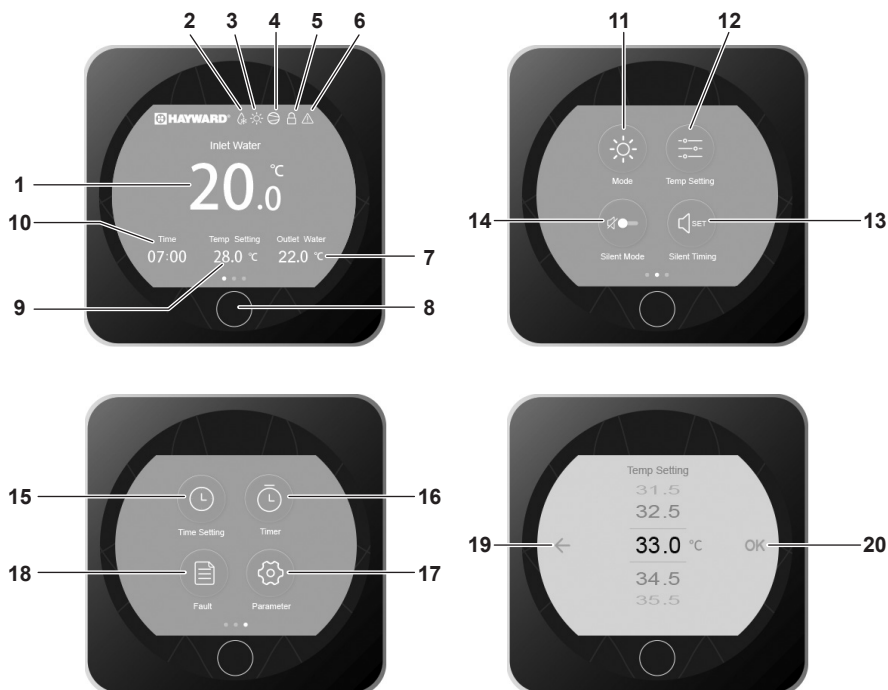

Legenda

1	Temperatura acqua in Ingresso
2	Modalità sbrinamento
3	Modalità di funzionamento
4	Spia di accensione del compressore
5	Blocco dello schermo
6	Allarme
7	Temperatura di uscita dell'acqua
8	On/Off/Ritorno
9	Temperatura prefissata
10	Ora

11	Selezione della modalità di funzionamento
12	Regolazione del valore prefissato
13	Regolazione timer modalità silenziosa
14	Attivazione della modalità silenziosa
15	Regolazione data e ora
16	Regolazione Timer ON/OFF
17	Accesso parametri avanzati
18	Accesso elenco delle anomalie
19	Ritorno (senza convalida)
20	Convalida

4. INTERFACCIA UTENTE (segue)

Modalità OFF

Quando la pompa è ferma (in attesa), la scritta OFF viene visualizzata come indicato sullo schermo. Lo schermo nero indica che la pompa è ferma: i parametri possono essere impostati con questa modalità.



Modalità ON

Quando la pompa funziona o è in corso di regolazione (raggiungimento del valore prefissato) lo schermo diventa blu.



Per passare da OFF a ON e viceversa premere il pulsante .

4. INTERFACCIA UTENTE (segue)

4.2 Impostazione di Data e Ora

L'impostazione della data e dell'ora può essere effettuata con modalità ON o OFF.



- Premere 1 volte  per tornare alla schermata principale.

4. INTERFACCIA UTENTE (segue)

4.3 Regolazione dei Timer ON/OFF

La configurazione di questa funzione è necessaria se si desidera azionare l'unità per un periodo più breve rispetto a quello impostato tramite l'orologio che regola l'azionamento della pompa di filtraggio. In questo modo, è possibile ritardare l'avvio, anticipare l'arresto o impedire l'avviamento dell'unità durante una determinata fascia oraria (ad esempio di notte).

È possibile programmare fino a un Timer Partenza e un Timer Stop.
Il passo di regolazione è «di ora» in ora».



4. INTERFACCIA UTENTE (segue)



Evidenziato blu = Attivato
Grigio = Disattivato

- Premere 2 volte  per tornare alla schermata principale.

4. INTERFACCIA UTENTE (segue)

4.4 Regolazione del valore prefissato

L'impostazione del valore prefissato viene effettuata sia con modalità ON che con modalità OFF, con una tolleranza di 0,5°C.



- Premere 1 volte  per tornare alla schermata principale.



Si raccomanda di non oltrepassare la temperatura di 30°C al fine di evitare di alterare i liner.

4. INTERFACCIA UTENTE (segue)

4.5 Blocco e sblocco del touch screen

Lo schermo può essere bloccato e sbloccato sia con modalità ON che con modalità OFF.



Blocco attivato



Blocco disattivato

4. INTERFACCIA UTENTE (segue)

4.6 Configurazione della funzione SILENCE

La modalità silenzioso permette di usare la pompa di calore risparmiando energia e generando molto meno rumore quando le esigenze di riscaldamento sono ridotte (mantenimento della vasca a temperatura o necessità di avere un funzionamento ultrasilenzioso).

Questa funzione può essere attivata o disattivata manualmente o tramite un timer.

Attivazione/ Disattivazione



Modalità silenziosa disattivata



Modalità Silenzioso attivata



- Premere 1 volte  per tornare alla schermata principale.

4. INTERFACCIA UTENTE (segue)

Regolazione della modalità SILENZIOSA su Timer



4. INTERFACCIA UTENTE (segue)



- Premere 2 volte  per tornare alla schermata principale.



***Il passo di regolazione è «di ora in ora».
Una volta attivato, il Timer rimane attivo 7 giorni su 7.***

5. MANUTENZIONE E SVERNAMENTO

5.1 Manutenzione

Per garantire la longevità e il corretto funzionamento dell'Unità di Riscaldamento a Pompa di Calore per Piscine, le presenti operazioni di manutenzione devono essere effettuate 1 volta all'anno.

- Pulire l'evaporatore con una spazzola morbida, un getto di aria compressa o con acqua (**Attenzione: non utilizzare in nessun caso idropulitrici**).
- Controllare che lo scarico della condensa avvenga correttamente.
- Controllare che i collegamenti idraulici e quelli elettrici siano serrati correttamente.
- Controllare la tenuta idraulica del condensatore.
- Far controllare la tenuta del circuito frigorifero al rilevatore di perdite da un **professionista autorizzato**.



Prima di eseguire qualsiasi operazione di manutenzione, assicurarsi che l'unità sia scollegata da ogni fonte di corrente elettrica. Le operazioni di manutenzione devono essere effettuate esclusivamente da personale qualificato e abilitato alla manipolazione di fluidi frigoriferi.

5.2 Svernamento

- Mettere l'unità in Modalità "OFF".
- Interrompere l'alimentazione dell'unità.
- Svuotare il condensatore tramite l'apposito scolo per evitare eventuali rischi di degrado. (elevato rischio di congelamento).
- Chiudere la valvola by-pass e svitare i raccordi di unione ingresso/uscita.
- Eliminare dal condensatore l'acqua stagnante residua servendosi di una pistola ad aria compressa.
- Ostruire l'ingresso e l'uscita dell'acqua dell'unità, al fine di evitare l'eventuale intrusione di corpi estranei.
- Coprire l'unità con l'apposito telo per l'inverno.



Una volta attivato, il Timer rimane attivo 7 giorni su 7.

6. APPENDICI (segue)

ECLI40MA (*)

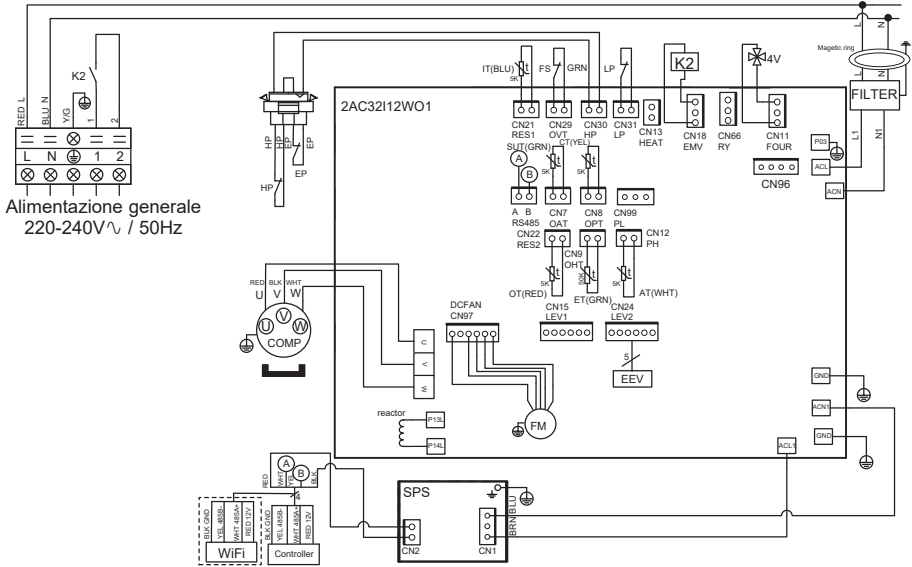

LEGENDA:

- | | |
|--|--|
| AT : Sonda temperatura aria | LP : Pressostato bassa pressione |
| COMP : Compressore | OT : Sonda temperatura acqua in uscita |
| CT : Sonda temperatura evaporatore | SU : Sonda temperatura aspirazione |
| EEV : Regolatore di pressione elettronico | 4V : Valvola 4 vie |
| FM : Motore ventola | K2 : Contatto pulito libero da potenziale 16A max. |
| FS : Rilevatore acqua | ET : Sonda temperatura di mandata |
| HP : Pressostato alta pressione | OPTIONAL : (indicated by a dashed box in the diagram) |
| IT : Sonda temperatura acqua in ingresso | |

(*) Verificare i riferimenti delle macchine mediante la tabella delle corrispondenze (vedi etichetta sulla copertina del manuale).

6. APPENDICI (segue)

6.2 Collegamenti priorità riscaldamento pompa monofase

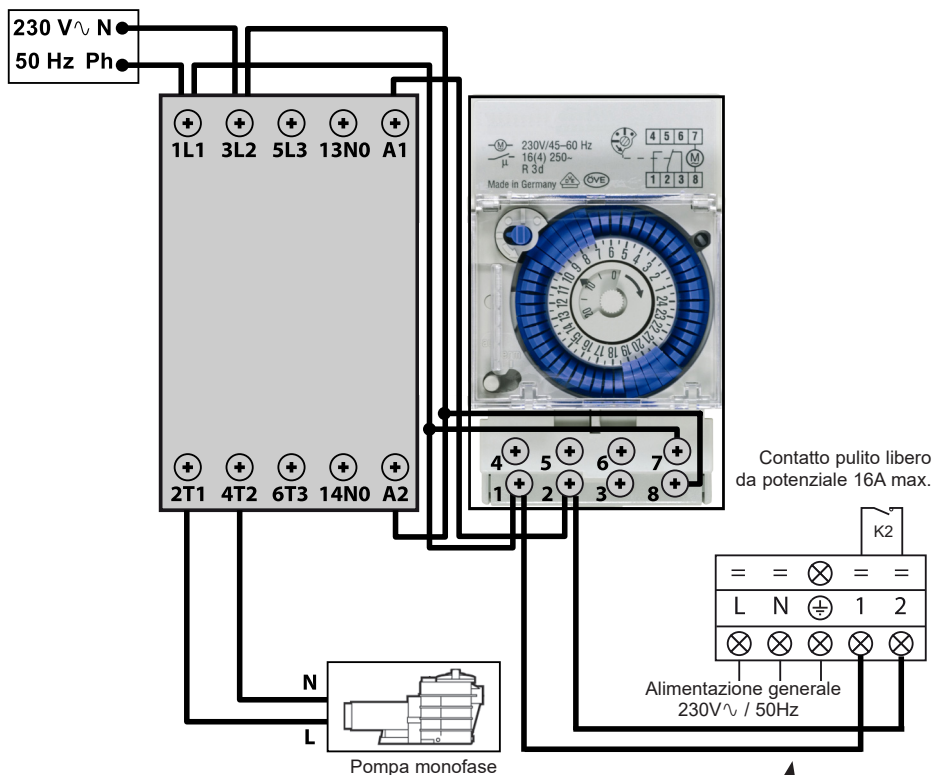

I morsetti 1 e 2 offrono un contatto pulito libero da potenziale, senza polarità 230 V \sim / 50 Hz.

Collegare i morsetti 1 e 2 come indicato nello schema di cablaggio di cui sopra per garantire il funzionamento della pompa di filtraggio per un ciclo di 2 min. ogni ora qualora la temperatura all'interno della vasca fosse inferiore al set point impostato.

 Non collegare l'alimentazione della pompa di filtraggio direttamente ai morsetti 1 e 2.



Pagina lasciata intenzionalmente bianca

6. APPENDICI (segue)

6.3 Esplosi e parti di ricambio / Addendum

ECLI15MA / 20MA / 30MA / 40MA (*)

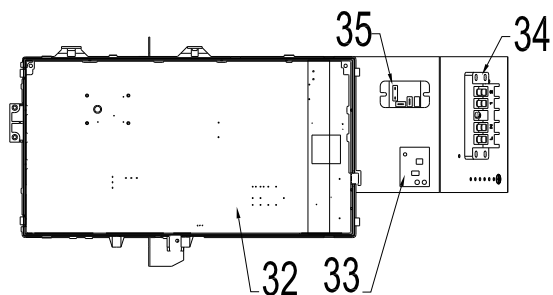
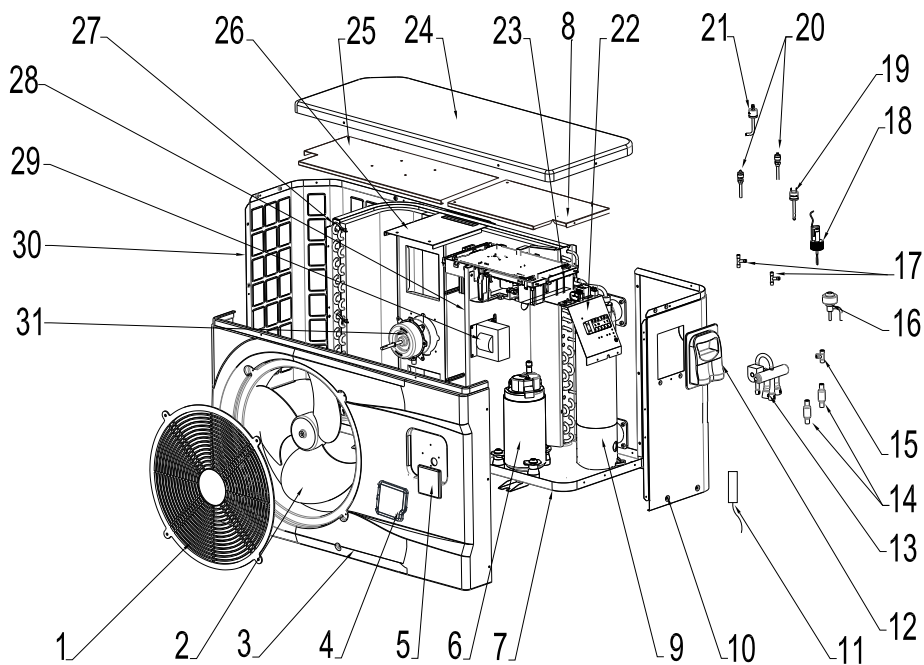

6. APPENDICI (segue)

Num.	Designazione	Rif.	ECLI15MA*	ECLI20MA*	ECLI30MA*	ECLI40MA*
1	Griglia di protezione ventilatore	HWX20000220245	✓	✓	✓	n/a
		HWX20000220369	n/a	n/a	n/a	✓
2	Elica ventilatore	HWX301030000006	✓	✓	✓	n/a
		HWX301030000001	n/a	n/a	n/a	✓
3	Pannello anteriore	HWX809000099	✓	✓	✓	n/a
		HWX809001100	n/a	n/a	n/a	✓
4	Porta di protezione	HWX809000320	✓	✓	✓	✓
5	Regolatore LED	HWX82300038	✓	✓	✓	✓
6	Compressore	HWX20000110448	✓	✓	✓	n/a
	Compressore	HWX80100003	n/a	n/a	n/a	✓
7	/	/	/	/	/	/
8	/	/	/	/	/	/
9	Condensatore Titanio/PVC	HWX80600037	✓	n/a	n/a	n/a
		HWX32012120061	n/a	✓	n/a	n/a
		HWX32012120056	n/a	n/a	✓	n/a
		HWX806000096	n/a	n/a	n/a	✓
10	Pannello destro	HWX80700445	✓	✓	✓	n/a
		HWX80700314	n/a	n/a	n/a	✓
11	Sonda di aspirazione compressore 5k-560mm	HWX83000044	✓	✓	✓	n/a
	Sonda di aspirazione compressore 5k-760mm	HWX83000053	n/a	n/a	n/a	✓
	Sonda temperatura aria 5k-350mm	HWX83000049	✓	✓	✓	✓
	Sonda uscita acqua 5k-410mm	HWX83000050	✓	✓	✓	✓
	Sonda temperatura acqua in ingresso 5k-850mm	HWX83000052	✓	✓	✓	✓
	Sonda scarico compressore 50k-660mm	HWX83000026	✓	✓	✓	✓
	Sonda antigelo 5k-680mm	HWX83000051	✓	✓	✓	n/a
Sonda antigelo 5k-1040mm	HWX83000045	n/a	n/a	n/a	✓	
12	Portello d'accesso scatola elettrica	HWX320922029	✓	✓	✓	✓
13	Valvola 4 vie	HWX20041437	✓	✓	✓	✓
14	Filtro ø9.7-ø9.7 (Ø19)	HWX20000140178	✓	✓	✓	n/a
	Filtro ø9.7-ø9.7 (Ø28)	HWX20041444	n/a	n/a	n/a	✓
15	Connettore a T ø9.52-2 x ø6.35(T) x 1.0	HWX30403000002	✓	✓	✓	✓
16	Riduttore di pressione elettronico	HWX20000140570	✓	✓	✓	n/a
		HWX81000013	n/a	n/a	n/a	✓
17	Connettore a T ø6.5-2 x ø6.5(T) x 0.75	HWX20001460	✓	✓	✓	✓
18	Rilevatore portata acqua	HWX83000012	✓	✓	✓	✓
19	Pressostato Bassa pressione NO 0.30MPa/0.15MPa	HWX20000360157	✓	✓	✓	✓
20	Rilevamento Pressione 40mm 1/2"	HWX20000140150	✓	✓	✓	✓
21	Pressostato Alta pressione NC 3.2MPa/4.4MPa	HWX20013605	✓	✓	✓	✓
22	/	/	/	/	/	/
23	/	/	/	/	/	/
24	Pannello superiore	HWX809000055	✓	✓	✓	n/a
		HWX301090200806	n/a	n/a	n/a	✓
25	/	/	/	/	/	/
26	supporto motore	HWX80700218	✓	✓	✓	n/a
		HWX80700248	n/a	n/a	n/a	✓

(*) Verificare i riferimenti delle macchine mediante la tabella delle corrispondenze (vedi etichetta sulla copertina del manuale).

6. APPENDICI (segue)

ECLI15MA / 20MA / 30MA / 40MA (*)

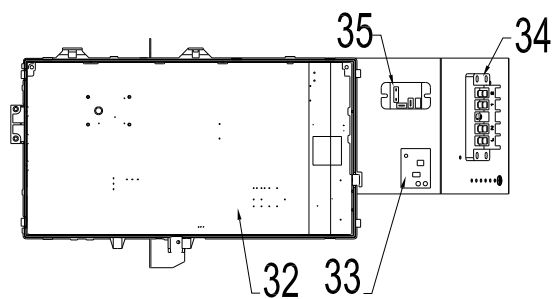
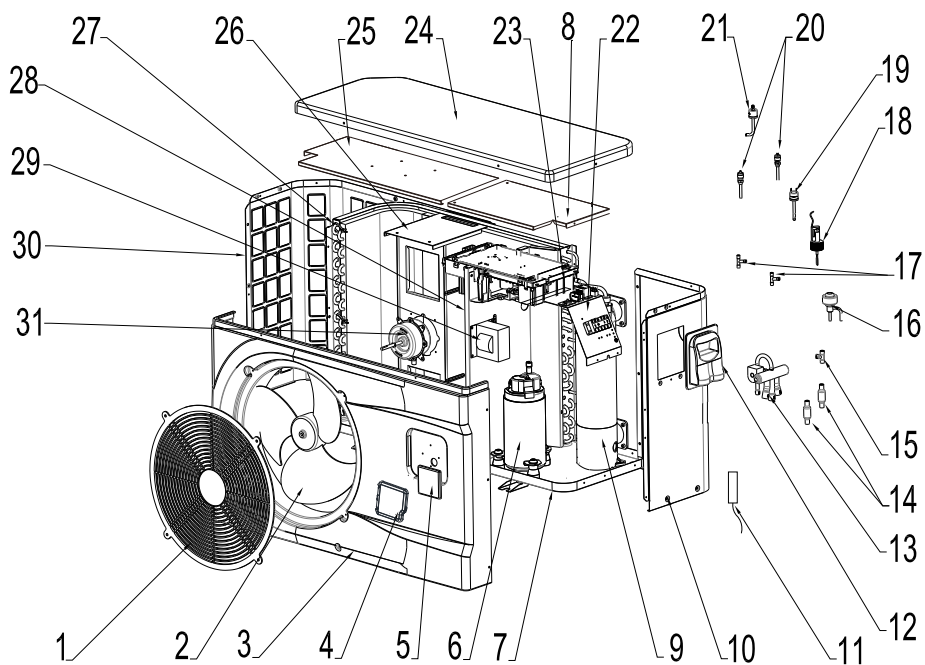

6. APPENDICI (segue)

Num.	Designazione	Rif.	ECL15MA*	ECL20MA*	ECL30MA*	ECL40MA*
27	Evaporatore a piastre	HWX301060202502	✓	n/a	n/a	n/a
		HWX80600042	n/a	✓	n/a	n/a
		HWX80600043	n/a	n/a	✓	n/a
		HWX80600044	n/a	n/a	n/a	✓
28	/	/	/	/	/	
29	Bobina 16A 50Hz 5mH	HWX82500006	✓	✓	✓	n/a
	Bobina 20A 50Hz 5.2mH	HWX82500005	n/a	n/a	n/a	✓
30	Pannello sinistro	HWX80700446	✓	✓	✓	n/a
		HWX80700315	n/a	n/a	n/a	✓
31	Motore ventola DC	HWX80200018	✓	✓	✓	n/a
		HWX20000330132	n/a	n/a	n/a	✓
32	Scheda elettronica Driver	HWX82300052	✓	✓	✓	n/a
		HWX82300007	n/a	n/a	n/a	✓
33	Trasformatore 230V~/12DC	HWX82600008	✓	✓	✓	✓
34	Morsettiera L-N-GND -5 connessioni 4mm²	HWX40003901	✓	✓	✓	✓
35	Relè K2	HWX20000360297	✓	✓	✓	✓

(*) Verificare i riferimenti delle macchine mediante la tabella delle corrispondenze (vedi etichetta sulla copertina del manuale).

6. APPENDICI (segue)

6.4 Guida alla Risoluzione dei Problemi





Alcune delle presenti operazioni devono essere effettuate da un tecnico autorizzato.

In caso di anomalia sulla pompa a calore, viene visualizzato il simbolo  nell'angolo superiore sinistro dello schermo.

In caso di problemi sullo schermo compaiono le seguenti indicazioni:



Una volta risolta l'anomalia, l'errore viene automaticamente risolto e il triangolo scompare.

- Per cancellare l'elenco degli errori, toccare .
- Premere 2 volte  per tornare alla schermata principale.

6. APPENDICI (segue)

Malfunzionamento	Codice errore	Descrizione	Soluzione
Guasto sonda temperatura acqua in ingresso	P01	Circuito aperto o cortocircuito	Verificare la connessione CN21/RES1 sulla scheda e il connettore prolunga oppure sostituire il sensore
Guasto sonda acqua in uscita	P02		Verificare la connessione N22/RES2 sulla scheda e il connettore prolunga oppure sostituire il sensore
Guasto sonda temperatura esterna	P04		Verificare la connessione CN12/PH sulla scheda e il connettore prolunga oppure sostituire il sensore
Guasto sonda antigelo	P05		Verificare la connessione CN8/OPT sulla scheda e il connettore prolunga oppure sostituire il sensore
Guasto sonda di aspirazione compressore	P07		Verificare la connessione CN7/OAT sulla scheda e il connettore prolunga oppure sostituire il sensore
Guasto sonda di mandata Compressore	P081		Verificare la connessione CN9/OHT sulla scheda e il connettore prolunga oppure sostituire il sensore
Protezione alta pressione	E01	Circuito aperto o cortocircuito	Verificare la connessione CN30/HP sulla scheda e il connettore prolunga oppure sostituire il sensore
			Controllare la portata d'acqua
			Controllare il sensore della portata d'acqua
			Controllare l'apertura delle valvole
			Controllare la valvola by-pass
			Controllare il livello di sporco dell'evaporatore
			Temperatura acqua troppo calda
			Problema incondensabile in seguito a manutenzione, svuotare e porre sottovuoto il circuito frigorifero
Carico fluido eccessivo, espellere il fluido in una bombola			
Protezione bassa pressione	E02	Circuito aperto o cortocircuito	Controllare i collegamenti AI/DI03 della scheda o sostituire il sensore
			Perdita rilevante di fluido frigorifero, cercare la perdita con il rilevatore
			Portata aria troppo bassa, controllare la velocità di rotazione della ventola
			Controllare il livello di sporco dell'evaporatore e pulirne la superficie
Guasto sensore di portata	E03	Circuito aperto o cortocircuito	Controllare i collegamenti AI/DI02 della scheda o sostituire il sensore
			Manca acqua, controllare che la pompa di filtrazione funzioni correttamente
			Controllare che le valvole di arresto siano aperte
			Controllare la regolazione della valvola by-pass

6. APPENDICI (segue)

Malfunzionamento	Codice errore	Descrizione	Soluzione
Differenza di temperatura Ingresso/ Uscita > 13°C	E06	Applicabile solo in modalità Freddo	Manca acqua, controllare che la pompa di filtrazione funzioni correttamente
			Controllare che le valvole di arresto siano aperte
			Controllare la regolazione della valvola by-pass
Protezione antigelo Modalità raffreddamento	E07	Temperatura acqua in uscita < a 4°C	Interrompere il funzionamento della pompa di calore, spurgare il condensatore antigelo
Guasto nel circuito di comunicazione	E08	Assenza di comunicazione tra la scheda elettronica e l'interfaccia utente	Verificare i collegamenti e la connessione – vedi schema elettrico
Protezione antigelo livello 1	E19	2°< Temperatura acqua <4° e Temperatura aria <0°	Interrompere il funzionamento della pompa di calore, spurgare il condensatore antigelo, la pompa di calore avvia automaticamente la pompa di filtrazione per evitare il gelo
Protezione antigelo livello 2	E29	Temperatura acqua < a 2° e Temperatura aria < 0°	Interrompere il funzionamento della pompa di calore, spurgare il condensatore antigelo, la pompa di calore avvia automaticamente la pompa di filtrazione e la pompa di calore per evitare il gelo.
Anomalie motore ventilatore	F031	Motore bloccato o difetto di collegamento	Verificare la corretta rotazione; verificare la connessione CN97/DCFan; sostituire il motore
Anomalie motore ventilatore	F051	Difetto di collegamento	Verificare la connessione DCFAN/ CN97; sostituire il motore
Temperatura esterna troppo bassa	TP	Raggiungimento del limite di funzionamento	Fermare la pompa

6. APPENDICI (segue)

6.5 Garanzia

CONDIZIONI DI GARANZIA

Tutti i prodotti HAYWARD sono garantiti contro tutti i difetti di fabbricazione o di materiale per un periodo di due anni dalla data di acquisto. Le eventuali richieste garanzia dovranno essere accompagnate dalla prova di acquisto comprovante detta data. Si raccomanda pertanto di conservare la fattura.

La garanzia HAYWARD è limitata alla riparazione o alla sostituzione, a discrezione della stessa HAYWARD, dei prodotti difettosi solo ed esclusivamente in caso di normale utilizzo e in conformità alle prescrizioni riportate nel manuale d'uso del prodotto; sarà altresì riconosciuta valida, qualora il prodotto in questione non sia stato in alcun caso alterato ed utilizzato esclusivamente in abbinamento a parti e componenti HAYWARD. Gli eventuali danni dovuti a gelo e ad attacchi di agenti chimici non sono coperti da garanzia.

Ogni altra spesa (trasporto, manodopera...) è esclusa dalla garanzia.

HAYWARD declina ogni responsabilità per danni, diretti o indiretti, riconducibili a installazione, collegamento o utilizzo non corretti del prodotto.

Per richiedere un intervento in garanzia e la riparazione o la sostituzione di un componente, rivolgersi ad un rivenditore autorizzato. Salvo previo accordo scritto, gli eventuali resi saranno respinti.

I componenti soggetti ad usura non sono coperti dalla garanzia.

Pagina lasciata intenzionalmente bianca

3. INSTALLATION OCH ANSLUTNING (fortsättning)

3.6 Inställning av vattenflödet

Justera den så kallade "överströmningsventilen" när vatteninlopps- och vattenutloppsventilerna är öppna, för att erhålla en temperaturskillnad på 2°C mellan vattnets inlopps- och utloppstemperatur (se principalschemat punkt 3.1). Du kan kontrollera inställningen genom att åskådliggöra inloppstemperaturen/ utloppstemperaturen direkt på manöverpanelen.



Anmärkning: När den så kallade "överströmningsventilen" öppnas, minskar flödet vilket leder till att ΔT ökar. När den så kallade "överströmningsventilen" stängs av, ökar flödet vilket leder till att ΔT minskar.